

CL Challenger Lifts

Installation, Operation & Maintenance Manual

MODEL RJ15

ROLLING JACK

(Model 4030 Series 4-Post)

15,000 lbs Capacity

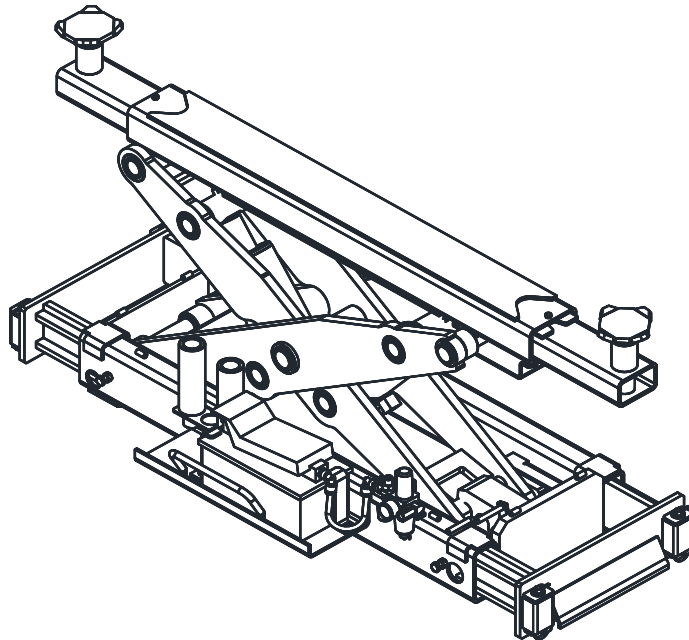

2311 South Park Road, Louisville, Kentucky 40219
Email: sales@challengerylifts.com Web site: www.challengerylifts.com

Office 800-648-5438 / 502-625-0700 Fax 502-587-1933

**IMPORTANT: READ THIS MANUAL COMPLETELY
BEFORE INSTALLING or OPERATING JACK**

⚠ CAUTION

- ◆ Before using this product, read and fully understand the operating instructions and all decals on the product. This is necessary to prevent injury to the operator and damage to the product.
- ◆ Roll jack forward before moving vehicle on or off lift.
- ◆ Do not attempt to use this jack for anything other than its intended purpose.
- ◆ If jack begins to tilt as the vehicle is raised, STOP! Lower jack and reposition the vehicle.
- ◆ Do not use this jack if it is visibly worn, distorted or damaged.
- ◆ Maximum air operating pressure not exceed 150 p.s.i.
- ◆ Always wear appropriate eye protection.

⚠ WARNING

- ◆ Lifting capacity of this jack is 1500lbs (Hydraulic Pressure at Cap. = 5200 psi) Exceeding this could result in severe personal injury or death.
- ◆ When the total lifting capacity of 2 rolling jacks differs from the rated capacity of the lift they are used on, the capacity of each jack should not exceed 1/2 the total capacity of the runways. Exceeding this could result in severe personal injury or death.
- ◆ Lift vehicle at manufacturer's recommended pick-up points only. Vehicle weight must be evenly distributed on each jack lift pad.
- ◆ Keep fingers and hands clear of all pinch points at all times.

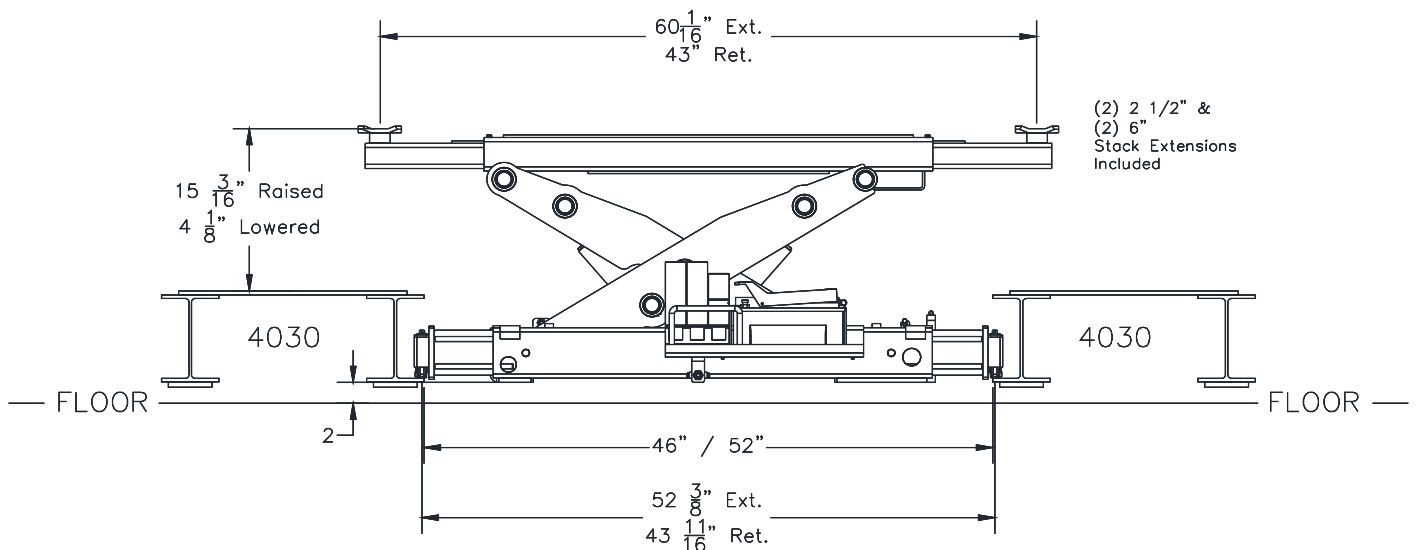

RJ15 Installation, Operation and Maintenance Manual

Fig. 1

INSTALLATION

- 1) Install a ¼ NPT male quick disconnect coupling in air inlet of F.L.R. pre installed on jack. Match to shop fittings.
- 2) Place jack assembly on lift rack rails.
- 3) Once side members are adjusted and jack is centered between the rails, tighten the (4) hex bolts (2 per side) to lock in place, Fig 2.

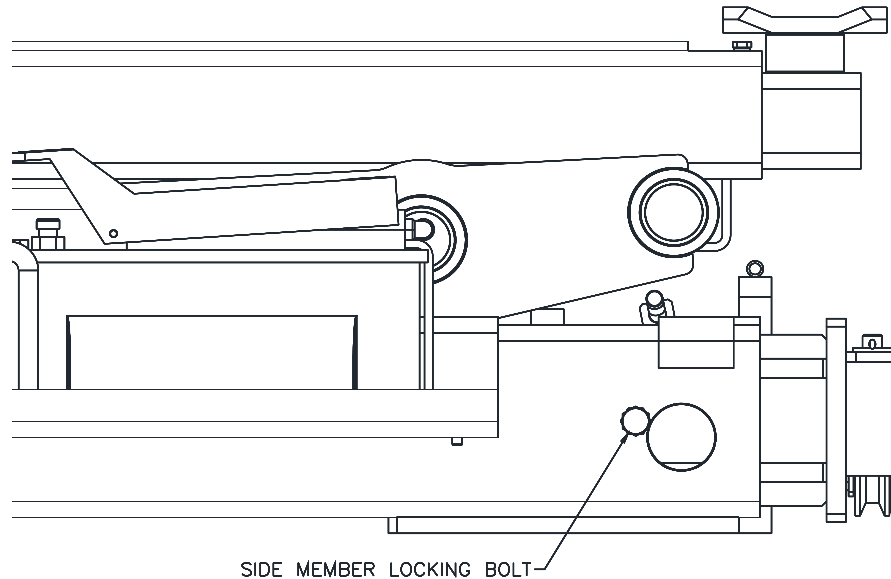

Fig. 2

Operation

Note: Before lifting a vehicle, operate the jack through a couple of cycles to become familiar with the controls.

- 1) Roll jack forward before moving vehicle on lift rack. Be sure vehicle is centered on rack, apply parking brake and chock wheels.
- 2) Roll jack(s) to the vehicle manufacturer's recommended pick-up points. Extend lift pad arms to proper lift points. Use lift pad spacers if necessary.
- 3) Raise jack by pushing on foot pedal on pump.
- 4) Raise vehicle to desired height.
- 5) Lower jack onto lock.
- 6) To lower jack completely, raise off of lock and while holding lock release handle open lower jack. Push lift pad arms in, remove lift pad spacers (if used). Roll jack forward before moving vehicle off rack.

Loss of power

If for any reason the lift will not raise off the locks or the locks will not retract, consult factory authorized personnel.

DO NOT OVERRIDE ANY SAFETY FEATURE IN AN ATTEMPT TO LOWER THE LIFT.

Maintenance

Daily: Inspect jack and it's components for damage or excessive wear. Replace parts as required. See parts list.

Inspect air/hydraulic system for leaks. Check in-line lubricator oil level.

Annually: Check hydraulic pump fluid level. When jack is completely lowered remove breather plug and check oil level. Oil should be at top of filler plug hole.

IMPORTANT!

Failure to keep lift free of corrosive agents and solvents will lead to reduced service life, which could result in property damage and/or personal injury. If any problems are encountered, contact your local service representative.

Notes

Parts Breakdown

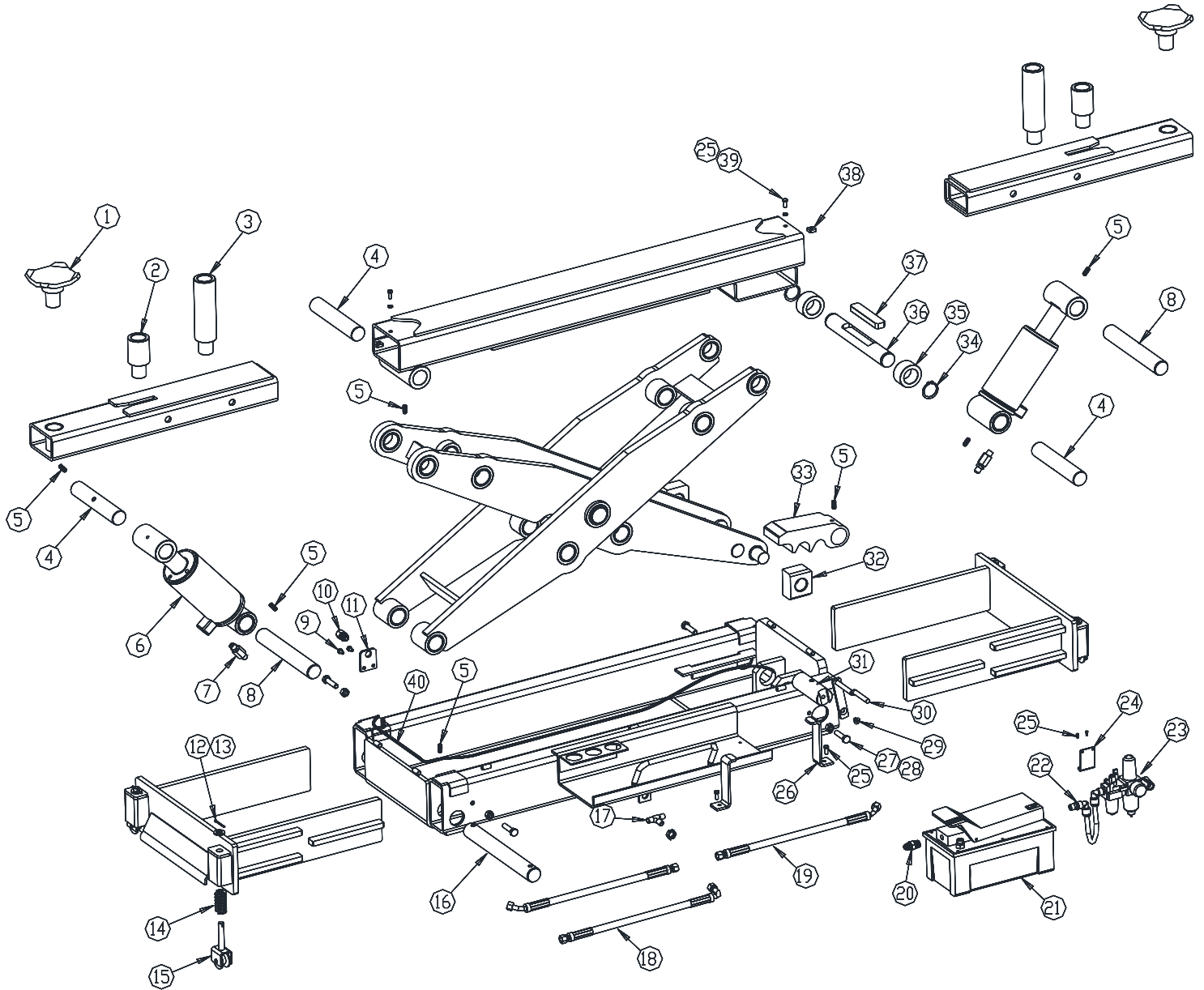

IMPORTANT!

Replace all worn, damaged, or broken parts with parts approved by **Challenger Lifts Inc.** or with parts meeting **Challenger Lifts Inc.** specifications.
Contact your local Challenger Lifts Parts Distributor for pricing and availability.
(Call Challenger Lifts Inc. (502) 625-0700 for the Parts Distributor in your area)

RJ15 Installation, Operation and Maintenance Manual

Item Number	Part Number	Qty/Jack	Description
1	RJ15-18-00	2	Footpad
2	RJ15-17	2	2 1/2" Footpad Extension
3	RJ15-16	2	6" Footpad Extension
4	RJ15-08	3	Inner Scissor Pin (1 3/8" O.D. x 7 1/4" Lg.)
5	S251399	7	M8 x 20mm Set Screw
6	RJ15-04-00	2	Cylinder
7	RJ15-26-00	2	Flow Restrictor Assembly
8	RJ15-20	2	Outer Scissor Pin (1 3/8" O.D. x 9" Lg.)
9	Q4P09-007	2	M6 x 10mm HHCS
10	JPCF6-02	1	M14 Bulk Fitting 1/4" NPT-ø6mm
11	RJ15-19	1	Bulk Fitting Mounting Plate
12	40126	4	1/8" x 1 1/2" Cotter Pin
13	QRJ9-32	4	M12 Washer
14	RJ15-02-03	4	Compression Spring
15	RJ15-02-02-00	4	Wheel Assembly
16	RJ15-09	1	Bottom Scissor Pin
17	RJ15-24	1	3/8" Bulkhead Tee JIC 6
18	RJ15-22	1	Hydraulic Hose Assembly (16 5/8" Lg.)
19	RJ15-21	2	Hydraulic Hose Assembly (26 3/8" Lg.)
20	JSJ4-19	1	Straight Union 3/8"/ JIC 6
21	TL-A5102-52	1	Air/Oil Pump (5200 PSI)
22	RJ6-31	2	Swivel Elbow 1/4" NPT-10mm Pushlock
23	24101	1	Filter/ Regulator/ Lubricator
24	RJ6-28ch	1	FRL Bracket
25	X10-026	6	M6 x 15mm HHCS
26	RJ15-25	2	Air/ Oil Pump Bracket
27	X10-063	4	M10 x 45mm HHCS
28	X10-019	4	M10 Nut
29	VS10-31-08	1	M8 x 10mm Flat Head Screw
30	RJ15-15-00	1	Lock Release Handle
31	RJ15-14	1	Lock Pawl Pin
32	RJ15-03-05	2	Slide Blocks
33	RJ15-13	1	Lock Pawl
34	B1083	2	35mm Retaining Ring
35	RJ15-12	2	Sliding Pin Spacer
36	RJ15-10	1	Sliding Pin
37	RJ15-11	1	Sliding Pin Sleeve
38	RJ15-07	2	Arm Stop Nut
39	X10-033	8	M6 Lock Washer
40	24102	1	1/4" Air Line Tubing x 2' Lg.

IMPORTANT!

Replace all worn, damaged, or broken parts with parts approved by **Challenger Lifts Inc.**
or with parts meeting **Challenger Lifts Inc.** specifications.

Contact your local Challenger Lifts Parts Distributor for pricing and availability.

(Call Challenger Lifts Inc. (502) 625-0700 for the Parts Distributor in your area)