

TRANSMISSION JACKS

TRANSMISSION JACKS

1,000 lbs Manual Telescopic Transmission Jack

700 lbs Economy Transmission Jack

1,000 lbs Air/Manual Telescopic Transmission Jack

2,000 lbs Air/Manual Telescopic Transmission Jack

1,000 lbs Manual Telescopic Transmission Jack

2,000 lbs Manual Telescopic Transmission Jack

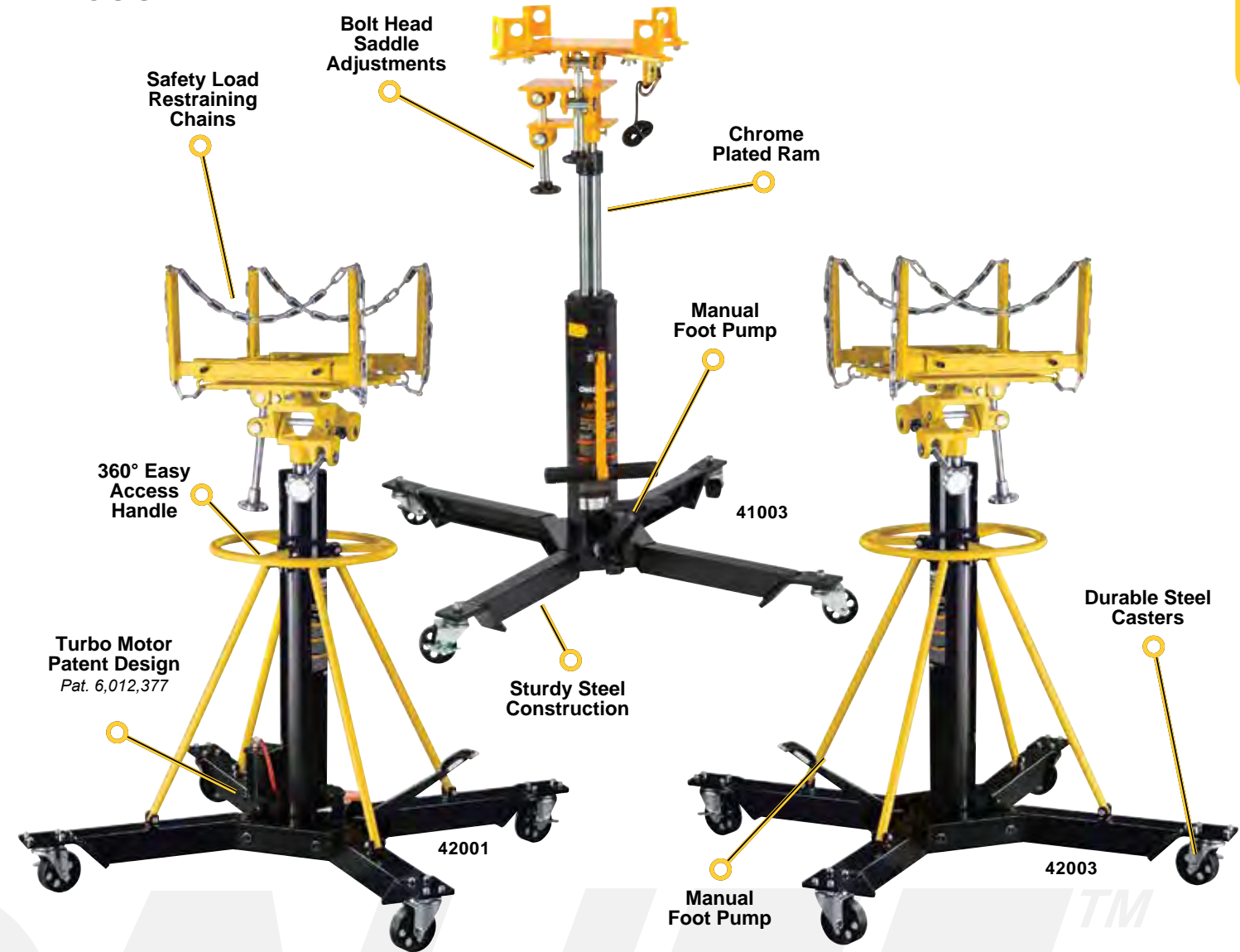
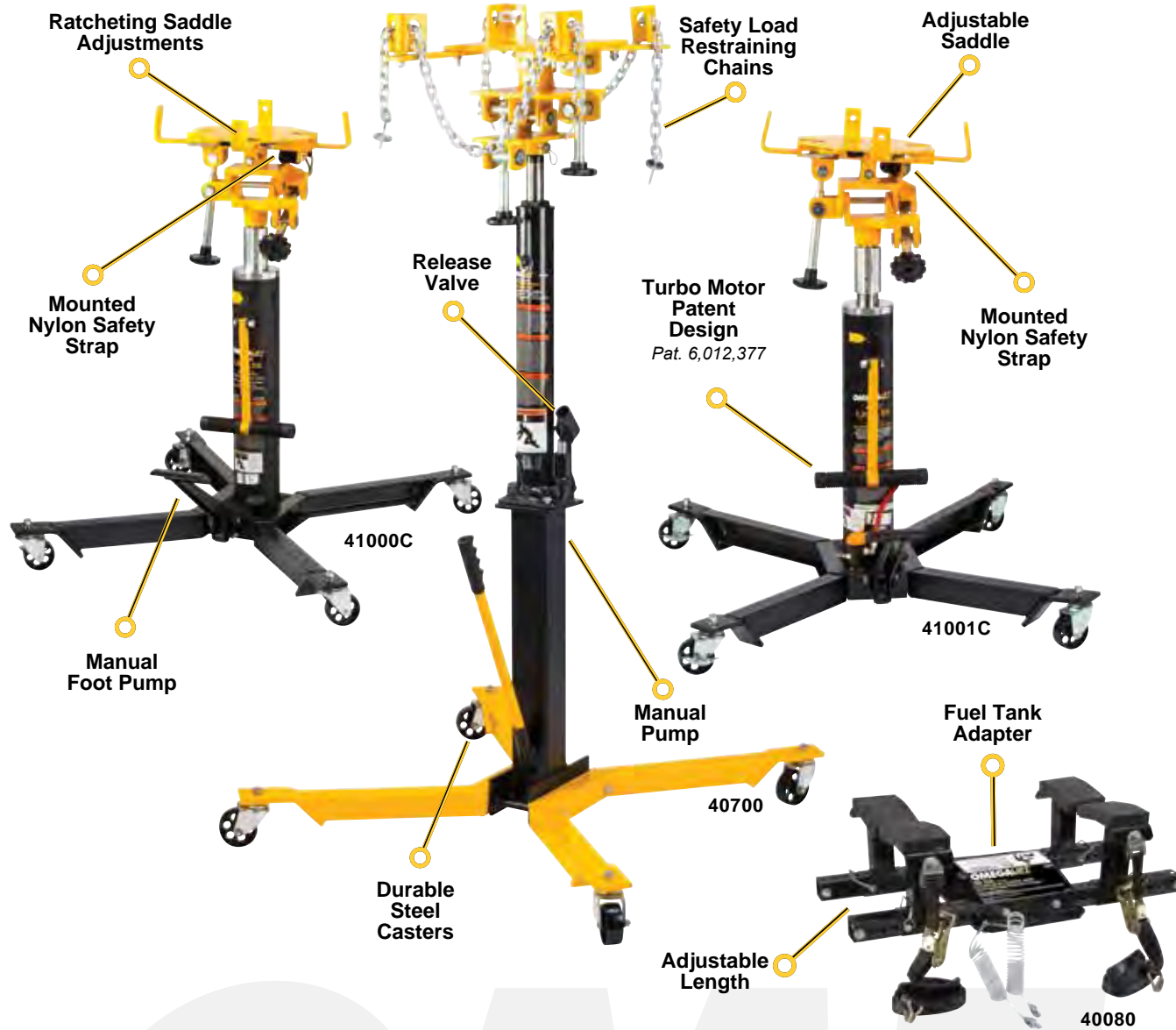

| Model | Description | Height (Min / Max) | | Saddle Base | | Extended Saddle | | Dimension (L x W) | | Weight |
|--------|---|--|--------|-------------|--------|-----------------|--------|-------------------|--------|------------|
| 40700 | 700 lbs Economy Transmission Jack | 57.25" | 76.38" | 9.88" | 9.88" | 18.88" | 18.88" | 36.13" | 32.63" | 137.28 lbs |
| 41000C | 1,000 lbs Manual Telescopic Transmission Jack | 39.88" | 77.25" | 11.50" | 11.50" | 21.00" | 21.00" | 33.13" | 35.50" | 161.00 lbs |
| 41001C | 1,000 lbs Air/Manual Telescopic Transmission Jack | 39.88" | 77.25" | 11.50" | 11.50" | 21.00" | 21.00" | 33.13" | 35.50" | 171.00 lbs |
| 40080 | Fuel Tank Adapter | Designed to fit onto Telescopic Transmission Jacks | | | | | | | | 55.00 lbs |

| Model | Description | Height (Min / Max) | | Saddle Base | | Extended Saddle | | Dimension (L x W) | | Weight |
|-------|---|--------------------|--------|-------------|--------|-----------------|--------|-------------------|--------|------------|
| 41003 | 1,000 lbs Manual Telescopic Transmission Jack | 36.25" | 73.00" | 9.88" | 9.88" | 20.25" | 20.25" | 36.50" | 34.00" | 145.20 lbs |
| 42001 | 2,000 lbs Air/Manual Telescopic Transmission Jack | 46.00" | 74.75" | 13.00" | 13.00" | 24.50" | 19.00" | 42.00" | 39.75" | 316.36 lbs |
| 42003 | 2,000 lbs Manual Telescopic Transmission Jack | 46.00" | 74.75" | 13.00" | 13.00" | 24.50" | 19.00" | 42.00" | 39.75" | 294.36 lbs |

* Excluding: 40080

