

BendPak®

AMERICA'S FAVORITE

SINCE 1965

MOBI-EVS™ EV BATTERY & POWERTRAIN LIFTING SYSTEM

Equipped with a host of advanced innovations in control and mobility, the Mobi-EVS™ drives productivity higher. Literally.

EV2400SL

2,400 lbs. Capacity

EV4000SL

4,000 lbs. Capacity



Meets or exceeds the standards as prescribed by ASME PASE 2019
(Safety Standard for Portable Automotive Service Equipment)

PATENT PENDING



MOBI-EVS™

BendPak's revolutionary Mobi-EVS™ line of full-rise battery powered mobile scissor lift tables are perfectly suited for Electric Vehicle Service and EV Battery Pack replacement. With their compact design, these space-saving lift tables can be easily transported anywhere in the workplace, making them ideal for multi-bay facilities or workplaces with confined areas.

With a press of the button on the pendant control, the lift platform elevates to more than 6 feet in less than 20 seconds. Mobi-EVS lift tables feature state-of-the-art engineering and technology within an elegant design that sets a new industry benchmark for performance and versatility.

Our Mobi-EVS models are multi-functional scissor-style lifts that feature multiple recessed anchoring locations for accommodating a variety of modular fixtures, adapters, and accessories. Each can be repositioned or removed as applications dictate.



ENHANCED FEATURES

Built Smart, Built Tough, Built To Last.

Every Mobi-EVS scissor-style lift table features a 1/4-inch-thick steel-reinforced deck plate that minimizes deflection, maximizes load stability, and greatly extends the life of the lift. For added strength and durability, structural steel channels are placed in both upper and lower frame sections providing additional rigidity and resistance to twisting or bending under load. Additional structural cross-members at every pivot joint in the scissor assembly minimizes leg deflection due to twisting or spreading under high, uneven loading.

Full-Length Utility Trays

During EV battery pack service, having all the necessities in easy reach is one of the most impactful strategies you can use to increase workplace productivity. All Mobi-EVS lifts feature full-length utility trays on both sides of the lift that provide ample storage for tools and fasteners within reach during all stages of service and battery pack removal for higher productivity on the shop floor.

Stowable Tow Bar

The tow bar handle can be stowed when not in use for compact convenience. The stow-and-go handle provides a space-saving solution by allowing users to quickly detach the tow handle from the lift providing more work-around clearance.

DC Electric Power System With Onboard Charging

Features a heavy-duty 12V DC power unit with deep cycle battery, an onboard battery charger, and battery charge indicator gauge that accurately displays the charge condition of the lift battery at all times. A rugged steel enclosure protects the power systems against falling debris and the ingress of water and other fluids.

Sized For Optimum Versatility

The 40" x 60" lift platform is ideal for safe, stable and delicate handling of battery packs and powertrain components through replacement and handling procedures. The lift rises to nearly six feet in less than 20 seconds and safely supports an industry-leading 4000-pound payload more securely than anything in its class.

Manual Floor Locks

Single-action tandem floor locks act as a parking brake when the lift is being loaded or used during battery pack and drivetrain installation. Spring-loaded foot operation locks and releases easily and durable urethane bottom pad offers maximum gripping power.

Zero-Throw Casters for Extreme Maneuverability

Revolutionary turn-on-a-dime zero-throw casters allow the lift table to move and change direction effortlessly, requiring a fraction of the effort normally associated with plain swivel casters. Durable nylon wheels help protect floor finishes and provide smooth mobility over uneven or rough surfaces.

Powder Coat Paint Finish

All Mobi-EVS models sport a durable baked-on powder coat finish that gives the metal a high-quality, sturdy finish that can withstand even the harshest environmental or chemical conditions. This results in a more robust coating with a better finish than baked enamel, without the environmental concerns of a solvent paint process.



Best in Class



Utility Trays



12V DC Power System

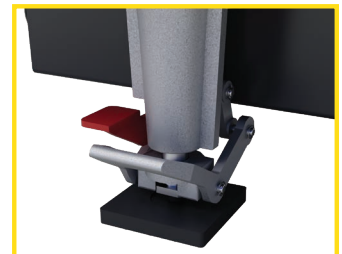

Floor Locks

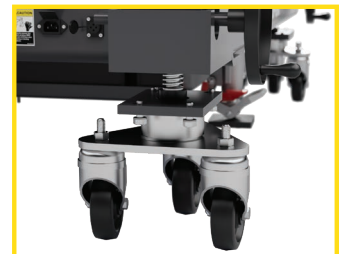

Zero-Throw Casters

PATENT PENDING

ENHANCED FEATURES

Side-To-Side Adjustments Made Easy

Integrated slip-plate deck features low rolling resistance maintenance-free ball retainers and nylon bearings that enable effortless side-to-side shifting of the tabletop for even more adjustability and precise alignment. 1-1/2" of adjustment in both axis' allows a variety of positioning options and increased versatility when servicing heavy batteries or powertrain components.

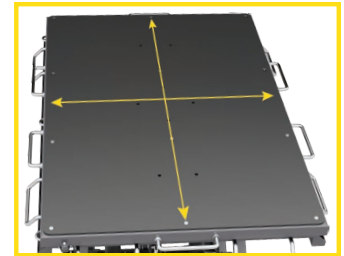

Slip Plate

Impact Resistant Protection

Extremely durable and impact-resistant Ultra-High Molecular Weight (UHMW) Polyethylene protects the tabletop from wear and tear and provides a low-friction surface allowing technicians to shift heavy components back and forth on the tabletop with less effort.

Remote Control Operation

A standard hand pendant controller made of high-impact ABS plastic features an eight-foot lead, allowing convenient one-man control on all sides of the lift. An Emergency Stop shuts off power to the lift instantly with a simple push of a button. Included is a convenient storage bracket that safely stows the hand pendant when not in use.



Remote Controller

Adjustable Screw Jacks

Adjustable screw jacks on each corner provide effortless pitch and roll adjustments for precise alignment and leveling of EV batteries, engine and drivetrain assemblies, fuel tanks, and more. This patented design greatly reduces the amount of time and effort required by technicians when adjustments are required.

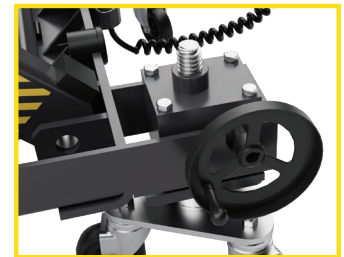

Screw Jacks

Hydraulic Fail-Safe Circuit

Integrated hydraulic velocity fuses completely stop the lift in the unlikely event of uncontrolled descent due to a sudden hydraulic system failure. The velocity fuse monitors the flow rate of the hydraulic fluid out of the cylinder and locks the platform in place if it exceeds the allowable rate.

Multi-Position Mechanical Safety Lock

Our Mobi-EVS lift tables have three safety lock positions (low, mid-level, and max height) which lets you select the right height for your needs. The safety lock secures the load whenever the platform is lowered, and pressure is relieved from the hydraulic pistons. A handsfree release operation allows you to efficiently raise, then lower the lift to the desired height, all from the pendant control.



Safety Lock

Satisfaction Guarantee

Our Mobi-EVS lifts are backed by a 24-month limited warranty on the hydraulic system (including power unit and cylinders); an 18-month limited warranty on the complete structure; and 12-month coverage on parts, hardware, and on-site labor. Providing the best warranty in the business is proof that we took a little extra care building your lift, and every precaution was taken to maintain the highest degree of quality, dependability and reliability. For full details, visit www.bendpak.com/support/warranty.

Twin Hydraulic Cylinders

Twin hydraulic cylinders feature welded construction, chrome-plated rods, and high polished bores for extended seal life. Proprietary seal design reduces leakage and increased seal life for long-lasting, dependable operation.



Twin Cylinders Design

PATENT PENDING

SPECIFICATIONS

Model	EV2400SL	EV4000SL
Lifting Height	75.75" (1,924 mm)	
Platform Capacities	2,400 lbs (1,089 kg)	4,000 lbs. (1,814 kg)
Overall Length	90" (2,286 mm)	
Overall Length (Handle Stowed)	65" (1,651 mm)	
Overall Width	46" (1,168 mm)	
Platform Size	40" x 60" (1,016 mm x 1,524 mm)	
Stowed Height	21.5" (546 mm)	
Raise / Lower Time (Max. Rise)	18 seconds	
Power Source	12V deep cycle DC battery	
Shipping Weight	1,518 lbs. (689 kg)	1,597 lbs. (724 kg)

*Specifications subject to change without notice. Photos and diagrams are shown for illustrative purposes only. BendPak makes no warranty, representation, or guarantee regarding the information contained herein or the suitability this equipment for any particular purpose. Always refer to the operator's manual for detailed instructions on the proper use and maintenance.

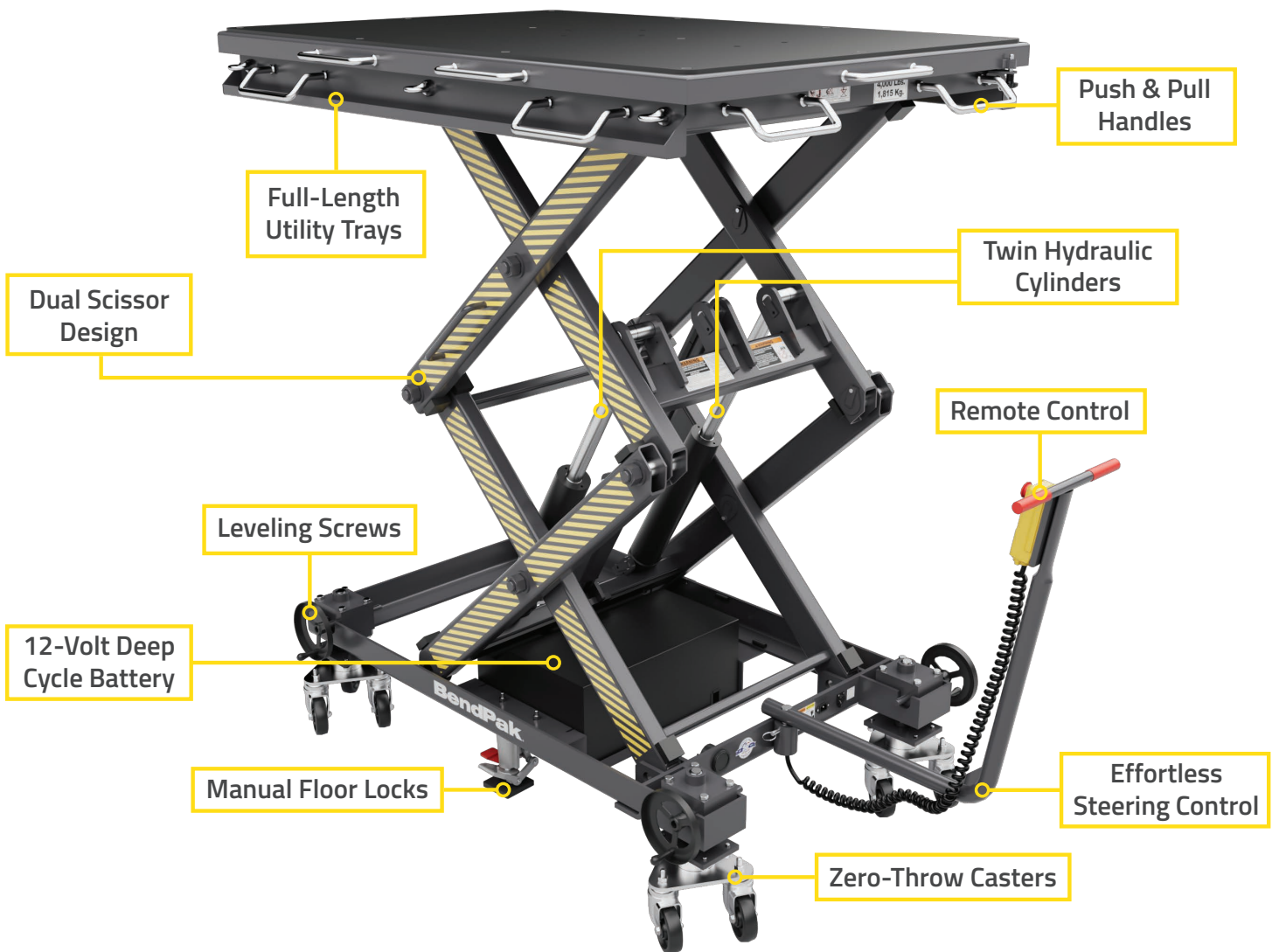

ACCESSORIES

EXPAND YOUR SERVICE CAPABILITY TO MEET GREATER DEMAND

Our line of Mobi-EVS electric-hydraulic lift tables feature recessed anchoring locations for accommodating a variety of modular fixtures, adapters, and accessories. Each can be repositioned or removed as applications dictate.

SKU 5210272 Set of 4



Mobi-EVS Telescoping Arm Kit

This telescoping arm kit attaches easily to the lift deck, providing a multitude of support options. The kit comes complete with four telescoping lift arms, four adjustable height contact pads and four stackable adapters that provide multi-configurable support of large, heavy, and awkward vehicle components. 600 lbs. capacity each arm.

SKU 5210305 Set of 4



Mobi-EVS Fixture Set

These multi-adjustable Accu-Point™ support fixtures create a dynamic universal fitment that adapt to nearly any transmission, drivetrain or vehicle subframe shape. The kit comes complete with four adjustable support fixtures, four adjustable height contact pads, and four stackable adapters. 600 lbs. capacity each fixture.



SKU 5323189

Mobi-EVS Transmission Support

The transmission jack adapter is ideal for automotive or light truck transmission installation or removal. Bi-directional adjustable saddle adapts to most auto and light truck transmissions, transfer cases or differentials. Includes hold-down chains. Requires #5216120 Universal Deck Mount Kit.

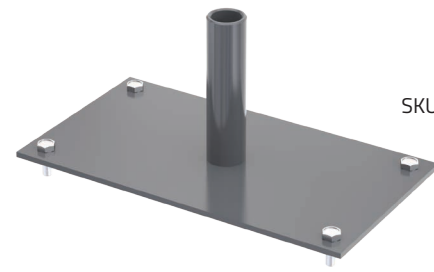

SKU 5216120

Mobi-EVS Universal Deck Mount Kit

This universal adapter plate features a center support pin that adapts to virtually all transmission jack heads, drivetrain adapters, and fuel tank supports on the market. Required for #5323189 Transmission Support and #5216205 Multi-Point Support Kit.



SKU 5216205

Mobi-EVS Multi-Point Support Kit

This 4-point adapter set features independently adjustable indexing arms that adapt to nearly any transmission, drivetrain or vehicle subframe shape. The kit comes complete with four telescoping support tubes, four adjustable height contact pads, and four stackable adapters. 800 lbs. capacity at maximum extension. Requires #5216120 Universal Deck Mount Kit.



MOBI-EVS™

**EV BATTERY & POWERTRAIN
LIFTING SYSTEM**

