

COATS®

Tread Scanner



Safety Instructions **Set Up Instructions** **Operation Instructions** **Maintenance Instructions**

READ these instructions before placing unit in service. KEEP these and other materials delivered with the unit in a binder near the machine for ease of reference by supervisors and operators.

HENNESSY
INDUSTRIES

1601 J. P. Hennessy Drive, La Vergne, TN USA 37086 615/641-7533 800/688-6359 www.coatsgarage.com
HENNESSY INDUSTRIES LLC Manufacturer of COATS®, AMMCO® and BADA® Automotive Service Equipment and Tools.

Manual Part No.: 85611868 00
Revision: 04/29

IMPORTANT SAFETY INSTRUCTIONS

READ ALL INSTRUCTIONS

1. Do not stare directly into light source of the unit.
2. Read and understand this manual before operating. Abuse and misuse will shorten the functional life.
3. Do not operate equipment with a damaged cord or if the equipment has been dropped or damaged – until it has been examined and repaired by a qualified serviceman.
4. Do not let cord hang over edge of table, bench, or counter or sharp metal object edges.
5. If an extension cord is necessary, a cord with a current rating equal to or more than that of the equipment should be used. Cords rated for less current than the equipment may overheat. Care should be taken to arrange the cord so that it will not be tripped over or pulled.
6. Keep guards and safety features in place and in working order.
7. Keep work area clean and well lighted. Clutter and/or dark areas invite accidents.
8. Avoid dangerous environments. Do not use power tools or electrical equipment in damp or wet locations, or expose them to rain.
9. Use only manufacturer's recommended accessories. Improper accessories may result in personal injury or property damage.
10. Repair or replace any part that is damaged or worn. Do not operate damaged equipment until it has been examined and serviced by an authorized service technician only. This unit contain no user serviceable parts.
11. Do not allow untrained persons to operate machinery.
12. To reduce the risk of fire, do not operate equipment in the vicinity of open containers or flammable liquids (gasoline).
13. Use equipment only as described in this manual. Do not modify the unit or remove protective covers or housings.
14. Use only manufacturer's recommended attachments and accessories.

SAVE THESE INSTRUCTIONS

	<p data-bbox="591 1587 662 1646"></p> <p data-bbox="719 1587 976 1646">NOTICE</p> <p data-bbox="477 1707 1218 1829">Read entire manual before assembling, installing, operating, or servicing this equipment.</p>
---	--

Table of Contents

Important Safety Instructions	ii	Maintenance Instructions	8
Owner's Responsibility	iv	Maintenance	8
Operator Protective Equipment	iv	Preventive Maintenance	8
Definitions of Hazard Levels	iv	Disposal and Scrapping	11
Symbols Used	iv	Charging the Battery	11
Important Notes	1	Error Codes	12
FCC Compliance (USA)	1	Software Configuration	14
Electromagnetic Compatibility (EMC)	1	Starting the System	14
User Group	1	Settings	14
Agreement	1	Display of Measurement Results	16
Basic Rules	2	Process and Test Protocol	17
Safety Instructions	2	Statistics	18
Set Up Instructions	3	Vehicle Data	18
Intended Use	3	Entering Vehicle Data	18
Information on Installation Location	4	Copying Measurement Results	19
Browser Recommendation	4	Technical Data	19
Smart-TV Recommendation	4	Technical Data Specifications	19
Operation Instructions	5		
Measurement Procedure	5		
Result of Measurement	7		
Switching Off Tread Scanner	7		

Owner's Responsibility

To maintain machine and user safety, the responsibility of the owner is to read and follow these instructions:

- Follow all installation instructions.
- Make sure installation conforms to all applicable Local, State, and Federal Codes, Rules, and Regulations; such as State and Federal OSHA Regulations and Electrical Codes.
- Carefully check the unit for correct initial function.
- Read and follow the safety instructions. Keep them readily available for machine operators.
- Make certain all operators are properly trained, know how to safely and correctly operate the unit, and are properly supervised.
- Allow unit operation only with all parts in place and operating safely.
- Carefully inspect the unit on a regular basis and perform all maintenance as required.
- Service and maintain the unit only with authorized or approved replacement parts.
- Keep all instructions permanently with the unit and all decals/labels/notices on the unit clean and visible.
- Do not override safety features.

Operator Protective Equipment

Personal protective equipment helps make tire servicing safer. However, equipment does not take the place of safe operating practices. Always wear durable work clothing during tire service activity. Loose fitting clothing should be avoided. Tight fitting leather gloves are recommended to protect operator's hands when handling worn tires and wheels. Sturdy leather work shoes with steel toes and oil resistant soles should be used by tire service personnel to help prevent injury in typical shop activities. Eye protection is essential during tire service activity. Safety glasses with side shields, goggles, or face shields are acceptable. Back belts provide support during lifting activities and are also helpful in providing operator protection. Consideration should also be given to the use of hearing protection if tire service activity is performed in an enclosed area, or if noise levels are high.

Eye Safety

Recommendation: Whenever possible do not look into the source of the beam. Use optional tinted glasses (OD1, optical density).



Definitions of Hazard Levels

Identify the hazard levels used in this manual with the following definitions and signal words:

DANGER

Watch for this symbol:



It Means: Immediate hazards, which will result in severe personal injury or death.

WARNING

Watch for this symbol:



It Means: Hazards or unsafe practices, which could result in severe personal injury or death.

CAUTION

Watch for this symbol:



It Means: Hazards or unsafe practices, which may result in minor personal injury or product or property damage.



Watch for this symbol! It means BE ALERT! Your safety, or the safety of others, is involved!

Symbols Used



Information: Practical hints and other useful information.



1. Multi-step operation: Instruction consisting of several steps.



One-step operation: Instruction consisting of one step.



Intermediate result: An instruction produces a visible intermediate result.



Final result: There is a visible final result on completion of the instruction.



Observe all hazard notices on products and ensure they remain legible.

Important Notes



Before start up, connecting and operating Coats brand products it is absolutely essential that the operating instructions/owner's manual and, in particular, the safety instructions are studied carefully. By doing so you can eliminate any uncertainties in handling Coats products and thus associated safety risks upfront; something which is in the interests of your own safety and will ultimately help avoid damage to the device. When a Coats product is handed over to another person, not only the operating instructions but also the safety instructions and information on its designated use must be handed over to the person.

FCC Compliance (USA)

Tread Scanner complies with the requirements of Section 15 of the FCC Rules. The following conditions apply regarding operation:

- Tread Scanner must not cause any harmful disruptions;
- Tread Scanner must be immune to interference and permit reception of interference, including interference that can cause unwanted operation.

Tread Scanner has been tested and found to comply with the limits for a Class B digital device, pursuant to Part 15 of the FCC Rules. These limits are designed to provide reasonable protection against harmful interference in a residential installation. Tread Scanner may generate, use and emit energy at radio frequencies that can disrupt radio communication if installed improperly or used in a manner inconsistent with the operating instructions. However, there is no guarantee that interference will not occur in a particular installation.

If Tread Scanner does cause harmful interference to radio or television reception, which can be determined by turning Tread Scanner off and on, the user is encouraged to try to correct the interference by one or more of the following measures:

- Reorient or relocate the receiving antenna.
- Increase the separation between Tread Scanner and receiver.
- Connect Tread Scanner into an outlet on a circuit different from that to which the receiver is connected.
- Consult the dealer or an experienced radio/TV technician for help.

All changes or modification to the Tread Scanner that are not expressly allowed by Coats can result in loss of permission to operate Tread Scanner.

Electromagnetic Compatibility (EMC)

Tread Scanner + ANPR satisfies the requirements of EMC directives 2014/30/EU and EN 55011.



This is a Class A, Group 1 device. The device may cause radio interference in residential environments. In such cases the operator may be required to take appropriate action.

Tread Scanner is a Class B product, Group 1 in line with 2014/130/EU, EN 55011.

Tread Scanner + ANPR and Tread Scanner are Group 1 devices: Group 1 includes all devices that have not been classified Group 2 devices.

Group 2 includes all ISM-HF devices in which HF energy of 9 kHz to 400 GHz is intentionally generated and/or used in form of electromagnetic radiation or by means of inductive or capacitive coupling to process material, for the purpose of material inspection or analyses, or to transmit electromagnetic energy.

Class A devices are devices that are suited for use in all areas except the living area and areas that are directly connected to a low-voltage system, which (also) supplies residential buildings.

Class B devices are devices that are suitable for use in the living area and areas that are directly connected to a low-voltage system, which (also) supplies residential buildings.

User Group

The product may be used by skilled and instructed personnel only. Personnel scheduled to be trained, familiarized, instructed or to take part in a general training course may only work with the product under the supervision of an experienced person.

All work conducted on electrical and hydraulic devices may be performed by persons with sufficient knowledge and experience in the field of electrics and hydraulics.

Children have to be supervised to ensure that they do not play with the appliance.

Agreement

By using the product, you agree to the following conditions:

Copyright

Software and data are the property of Coats or its suppliers and protected against copying by copyright laws, international agreements and other national legal regulations.

Copying or selling of data and software or any part thereof is impermissible and punishable; in the

event of any infringements Coats reserves the right to proceed with criminal prosecution and to claim for damages.

Liability

All data in this program is based - where possible - on manufacturer and importer details. Coats does not accept liability for the correctness and completeness of software and data; liability for damage caused by faulty software and data is ruled out. In any event, liability on the part of Coats is limited to the amount actually paid by the customer for the product concerned. This exemption from liability does not apply to willful damage or damage arising from gross negligence on the part of Coats.

Basic Rules

The shop owner is bound to ensure that all electrical equipment and operating material is set up, modified and maintained by skilled electricians only or under the guidance and supervision of a skilled electrician in accordance with electrical engineering principles.

Furthermore, the shop owner must ensure that all electrical equipment and operating material is operated in keeping with electrical engineering principles.

If a piece of electrical equipment or operating material is found to be defective, i.e. it does not or no longer complies with electrical engineering principles, the shop owner must ensure that the fault is rectified immediately and, in the event that imminent danger exists, also ensure that the electrical equipment or the electrical operating material is not used.

Tests:

- The shop owner must ensure that all electrical systems and equipment are tested by a qualified electrician or under the guidance of a qualified electrician to ensure they are in proper working order:

- Before starting for the first time.
- After modification or repair before starting for the first time.
- At given intervals. Set intervals such as to ensure that faults that can be expected to occur are determined in good time.

- The test is to take the electrical engineering principles relating hereto into account.
- Upon request of the trade association, a test manual is to be maintained into which specific entries are made.

Safety Instructions



Operator and bystanders must not stand in or near the measurement lane. Vehicles should maintain a low speed to ensure correct measurements and to protect operators and other bystanders near the unit.

Mains Voltages



Hazardous voltages are present both on the lighting mains and electrical systems of a motor vehicle.

Safety measures:

- Never touch live parts or components with damaged insulation.
- Only connect Tread Scanner to a properly grounded connection.
- Electrical connection only to be performed by a qualified electrician.
- Replace cables with damaged insulation.
- Inspect/check the electrical equipment every 2 years in conjunction with the test service and rectify any defects immediately.
- Prior to maintenance and repair work, unplug the mains connector or switch off the main switch for the power supply in the case of a permanently connected power cord.

Danger of Tripping



Sensor and connecting cables cause heightened danger of tripping during test and installation work.

Safety measures:

- Route the connecting cables such that there is no risk of tripping. Safety measures:

Set Up Instructions

Intended Use

The tread pattern measurement tool Tread Scanner is intended for the indoors optical measuring of the tread depth of passenger cars and commercial vehicles up to 4.4 ton (4 t.). Any other or additional application does not constitute intended use.

❑ Tread Scanner is not suitable for the measuring of vehicles with twin-tires.

The following tables contains all mandatory values of the vehicle to be tested.

Function	Specification
Number of Axles	2
Axle Load	up to 4.4 ton (4 t)
Wheel Load	up to 2.2 ton (2 t)
Track Width	42.5 to 71.6 inches (1080 to 1820 mm)
Rim Width	4.3 to 11.8 inches (110 to 300 mm)
Tread Depth	0.019 to 0.315 inches (0.5 to 8.0 mm)
Ground Clearance	min. 4.33 inches (min. 110 mm)
Height Deviation Vehicle Wheels Left to Right	max. 1.18 inches (max. 30 mm)
Crossing Speed	0.3 to 5 mph (0.5 to 8 kmh) <i>*Not to exceed 5 mph (8 kmh)</i>

Device Description

Tread Scanner consists of 2 measuring units ("Master" and "Satellite") with 2 ramps each to drive up and down, and an electrical cabinet.

Smart TV, screen or tablet and Access Point are necessary to display the results (to be ordered as optional accessories).

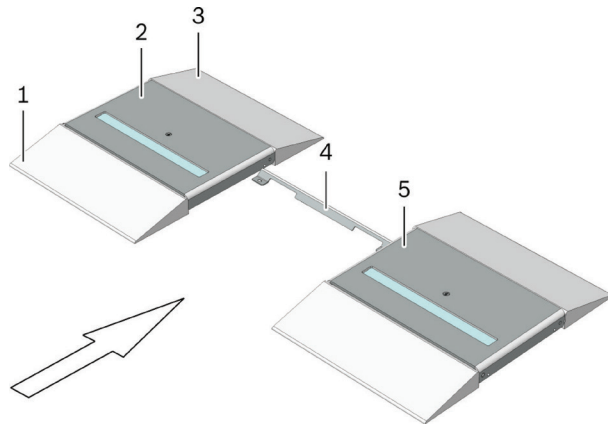

Fig. 1: Tread Scanner

- 1 Drive-up ramp
- 2 Measuring Unit "Master"
- 3 Drive-down ramp
- 4 Wireway
- 5 Measuring Unit "Satellite"

Scope of Delivery

Over-ground version for standard installation, order number 800ETOC.

Component	Quantity
Ramp	4
Measuring unit	2
Electrical cabinet	1
Power line, 10 m	1
Data cable	2
Squeegee for glass plates	1

Over-ground version for inspection pit, order number 800ETFC.

Component	Quantity
Ramp	4
Measuring unit	2
Electrical cabinet	1
Switch	1
Power line, 10 m	1
Data cable	2
Squeegee for glass plates	1

Spare Part, Wearing Parts and Special Accessory

Information can be obtained from your Coats® Certified Service Technician.

❑ The following components should be used for cable extensions by the customer:

RJ45 duplex clutch, shielded, 1:1, at least Cat 5E.

Data cable, at least Cat 5E, S-FTP.

The cable extensions must satisfy the requirements of the RHL (e.g. IP, chemical resistance, temperature range).

Information on Installation Location

General test conditions

- Only use the Tread Scanner indoors.
- No dirt or moisture below the Tread Scanner.
- The ground below the measuring unit must be suitable for an installation with dowels and for supporting the load of the central support.
- The ground must be even (for tolerances see Ground Evenness of Measuring Unit table).

☐ Limitation due to sunlight:

- Direct and intense solar radiation on the glass plates impair exact measurement.
- Remedy: Shading the measurement bay.

Electrical Connection

Connection of the Tread Scanner in the electrical cabinet must be done by a local specialist (110 V, 15 A).

Size

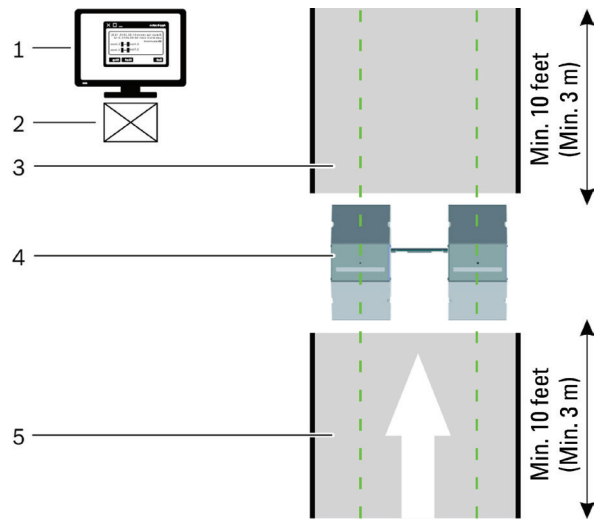

Fig. 2: Dimensions of Measurement Bay and System

No.	Designation	Dimension
1	Screen/Smart TV (special accessory) max. distance to Tread Scanner	26.25 feet (8 meter)
2	Electrical cabinet/Switch and access point - max. distance to Tread Scanner	26.25 feet (8 meter)
3	Straight drive-down path, min. length	10 feet (3 meter)
4	"Master" measuring unit	3.4 to 7.4 feet
5	"Satellite" measuring unit	(1.03 x 2.245 meter)
6	Straight drive-down path, min. length	10 feet (3 meter)

Ground Evenness of Measuring Unit

Permissible Height Difference	Value
Transverse direction (left to right)	0.196 inches (5 mm)
Longitudinal direction (front to rear)	0.118 inches (3 mm)
Diagonal direction (front/rear to left/right)	0.196 inches (5 mm)

Browser Recommendation

As a general recommendation, always use the current browser.

Desktop, Android, iOS

- Mozilla Firefox, version 28 or higher
- Google Chrome version 21 or higher or current browser with Chromium engine.

☐ Recommendation when using a browser on the PC: turn on full screen mode (F11 key in open browser).

☐ This device supports only Google Chrome and Mozilla Firefox.

Smart TV

- Samsung TV (Tizen operating system)

☐ Recommendation: to guarantee good display quality and speed, only use current screens.

Smart-TV Recommendation

☐ The Tread Scanner has been tested with Samsung smart TVs. There may be issues with smart TVs by other manufacturers.

Operation Instructions

Measurement Procedure

Switching on the Tread Scanner

Switch on the power supply for the Tread Scanner at the main switch of the electrical cabinet.

➤ After 30 seconds, the lighting of both measuring units must flash 3 times, and then stay lit.

➡ This means that the device is ready for operation.

☐ As soon as an object enters the detection zone some centimeters above the glass plate, the lighting switches to measurement mode (the light is brighter now).

☐ Run a test drive to check the quantity measurement system.

Calling Up the Tread Scanner Software

☐ The description of the software may vary due to the fact that there are various software and product versions in these operating instructions.

1. Start the web browser (tablet, PC, Smart TV).

2. Enter the IP address of the "Master" measuring unit configured during installation in the address input box.

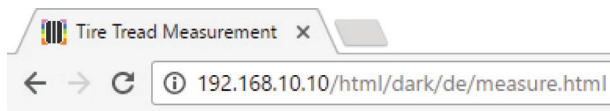

3. Make the displayed page the home page (see browser online help).

☐ Once the Tread Scanner software has been declared the home page, it is displayed automatically when starting the web browser or selecting the home button.

Crossing Specifications

➤ Heed the following vehicle data:

Function	Specification
Number of Axles	2
Axle Load	up to 4.4 ton (4 t)
Wheel Load	up to 2.2 ton (2 t)
Track Width	42.5 to 71.6 inches (1080 to 1820 mm)
Rim Width	4.3 to 11.8 inches (110 to 300 mm)
Tread Depth	0.019 to 0.315 inches (0.5 to 8.0 mm)
Ground Clearance	min. 4.33 inches (min. 110 mm)
Height Deviation Vehicle Wheels Left to Right	max. 1.18 inches (max. 30 mm)
Crossing Speed	0.3 to 5 mph (0.5 to 8 kmh) <i>*Not to exceed 5 mph (8 kmh)</i>

☐ With a center distance of 8 feet (2.5 m), crossing at <1 mph (0.5 kmh) takes 21 s, crossing at 5 mph (8 kmh) takes 1.6 s.



For heavily lowered vehicles: Cross the Tread Scanner at low speed to prevent the undercarriage from hitting the ground.

➤ Clean soiled vehicle tires (mud, snow, stones in the tread grooves) prior to the crossing.

➤ Check cleanness of the Tread Scanner glass plates. Clean glass plates, if needed.

☐ Dirty glass plates will falsify the measurement.

➤ Crossing in direction of travel, as centered as possible.

➤ Crossing at steady speed. Stopping is not required.

➤ The time lag between the crossing of the first and the crossing of the second axle must be below 10 seconds.

➤ After the crossing, keep driving or switch off the motor.

☐ If the vehicles is stopped with a running motor and the exhaust tailpipe above the diagnostic opening, this may cause the glass plates to fog.

☐ The tread depth varies across the tire diameter. That is why observational measurement value errors occur for repeated crossings.

☐ Problems with manual comparative measurements:

- Manual measurement point and automatic measurement point are not consistent.

- Application accuracy of manual vernier caliper depends on rim-width gauge (especially measuring probe), user and base of tread groove.

Measurement is possible in the following cases:

- When the crossing arrow flashes.

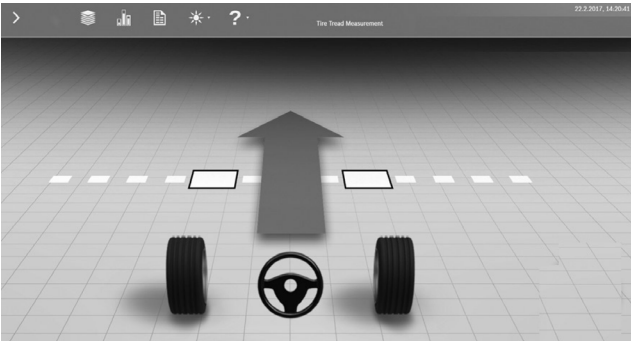

- When the last result of measurement is displayed.

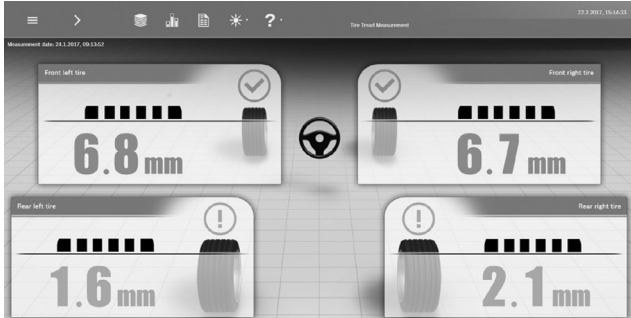

Measurement is not possible in the following cases:

- During an active, incomplete measurement procedure.
- ❑ Crossing is displayed as active as soon as the first axle of the vehicle crosses over the diagnostic opening.

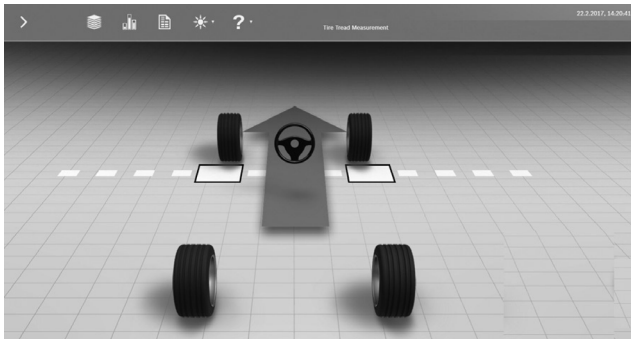

- While software and system are maintained.

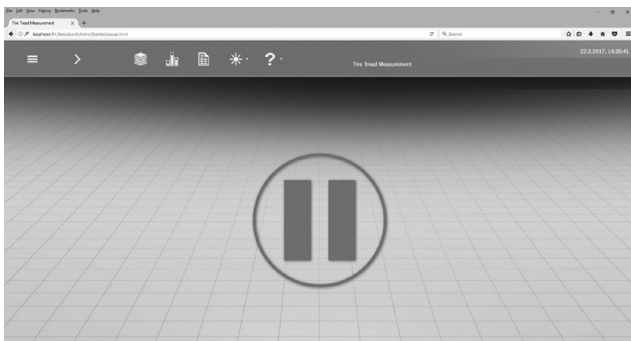

Measurement of Tread Depth

A vehicle's crossing is displayed on the screen as follows:

Both axles in front of the diagnostic modules

- Quantity measurement system is ready for vehicle crossing and measurement of the tread depth.

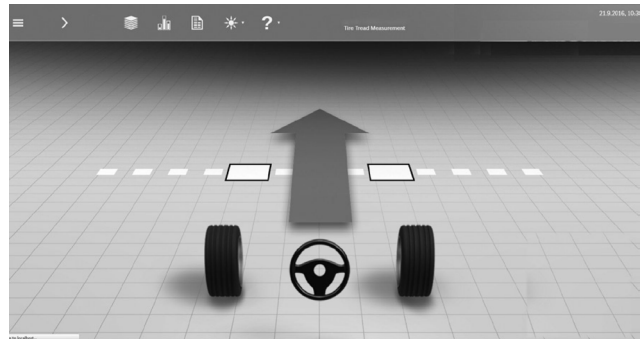

Front axle crosses diagnostic modules

- Quantity measurement system has detected the crossing of a tire on both measuring units.

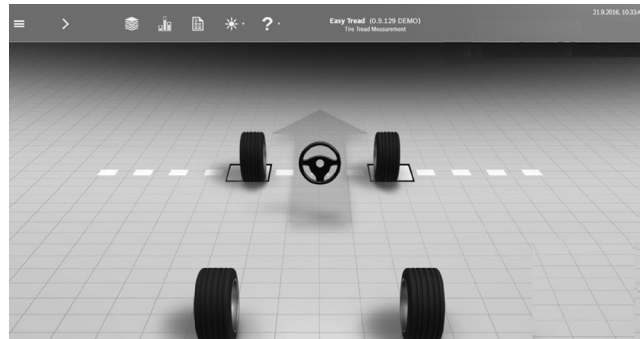

Rear axle crosses diagnostic modules

- Quantity measurement system has detected the crossing of at least 3 tires.

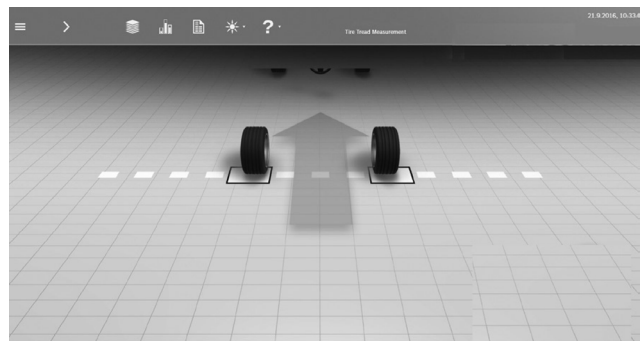

- The result of measurement is displayed some seconds after the crossing.

Result of Measurement

Display of Measurement Results

The result of measurement is displayed some seconds after the crossing.

- ▣ The result display type can be preset in the Settings menu (see Display of Measurement Results). The result display type can be changed temporarily while the result is displayed:

- Simple view.
- Standard view.
- Extended view.

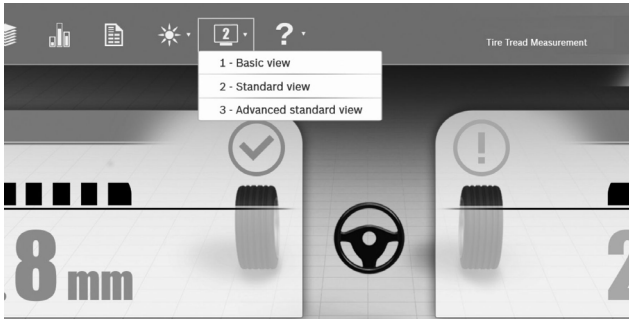

- ▣ After the result has been displayed, the next crossing is possible. The view switches to the preset result display type once the next crossing is started.

Print-Out of Measurement Results

1. Select **<Protocol>**.

- Print view test protocol of the last crossing is displayed.

2. Set protocol view preferences.

- Select right button to view the overall protocol width.
- Select left button to view the overall protocol height.

3. Select **<Print>** to print the protocol.

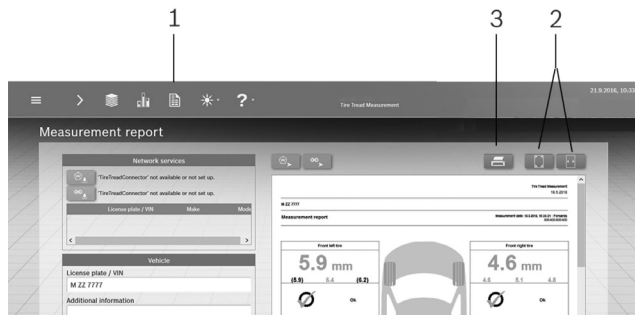

- 1 <Protocol>
- 2 Protocol views
- 3 <Print>

Process and Test Protocol

1. Select **<Process>** to display the process.

- ▣ New measurements are automatically added to the process display.

- ▣ Back to the crossing mode: select **<Crossing>**.

2. Highlight a line in the process display and select **<Protocol>** to display the protocol of the selected crossing.

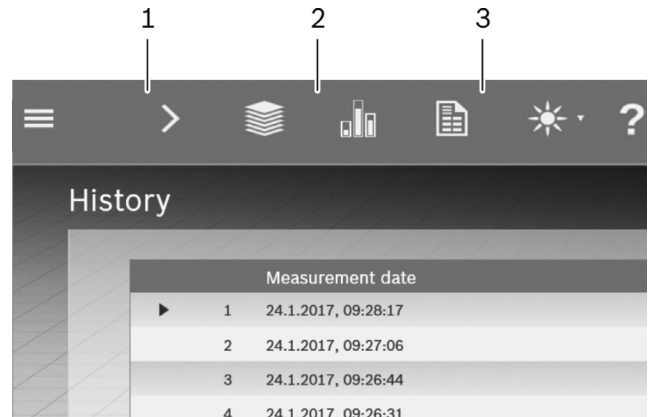

1 <Crossing>

2 <Process>

3 <Protocol>

3. Set protocol view preferences.

- Select right button to view the overall protocol width.
- Select left button to view the overall protocol height.

4. Select **<Print>** to print the protocol.

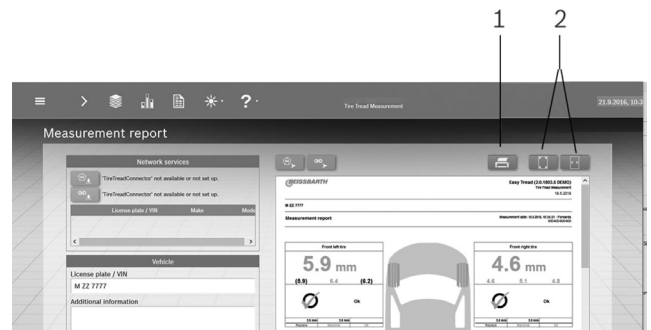

1 Protocol views

2 <Print>

Switching Off Tread Scanner

Switch off the power supply for the Tread Scanner at the main switch of the electrical cabinet.

Maintenance Instructions

Maintenance

Cleaning Intervals

- After a number of vehicle crossings.

Tire Surface Vehicle	No. of Vehicle Crossings
Dry, clean	1000
Wet, dirty	100

- In case of concrete soiling of the glass plate, cover plate or ramp (e.g. moisture, snow, leaves).

Activate Maintenance Mode

1. Select <Settings>.
2. Select operation mode **Maintenance** in the **General information** tab.
3. Select <Apply>.

➡ The measuring unit lighting is turned off.

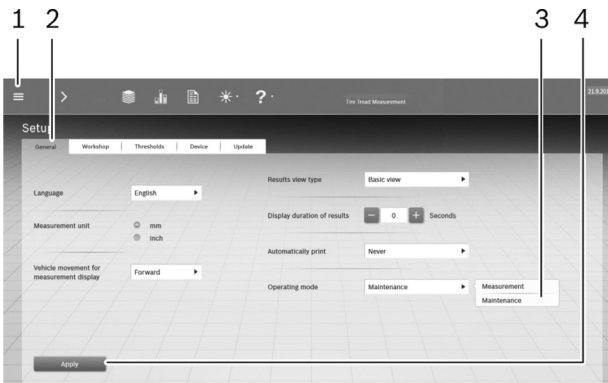

- 1 <Settings>
- 2 General information tab
- 3 Maintenance mode
- 4 <Apply>

Clean Measuring Units

1. Glass plates:
 - Flush with a lot of water and afterwards remove with the glass squeegee supplied.
- ❑ The glass plate has a functional high-quality coating that must not be destroyed. Damage leads to faulty measurements.

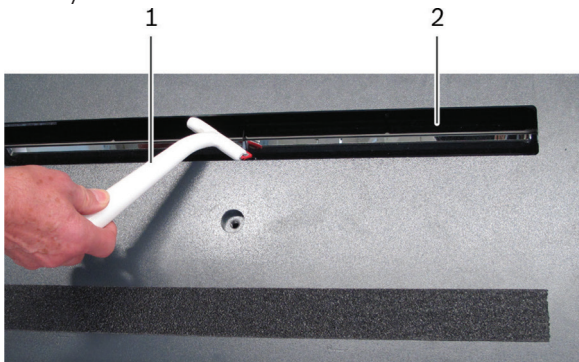

Fig. 3: Clean the Outside of the Measuring Units
 1 Squeegee
 2 Diagnostic opening with glass plate

1. Clean the outsides of the measuring units and reveals of the diagnostic openings with a paper cleaning cloth moistened with clear water.
2. Clean the internal spaces with the cover plates open:
 - Remove coarse material such as leaves and other small objects by hand.
 - Remove small objects with a vacuum cleaner.

3. After cleaning the interior: Check clearance below the diagnosis modules with a feeler gauge. The **clearance must be approx. 1/16 inch (2 mm)**.



High pressure cleaners, hard and sharp objects and microfibre cloths are not suitable for cleaning the Tread Scanner and damage the plates, plate coatings, seals and cables.

Activating the Measurement Mode

1. Select <Settings>.
2. Select operation mode Measurement in **General information** tab.
3. Select <Apply>.

Preventive Maintenance

The maintenance work described below must be performed by the user.



If components are damaged or worn or do not function properly: Inform the Coats customer service or an authorized service agent.

Service Intervals

Component	Action	As required	Every 3 months
Labels	Visual inspection: All labels are existent and clearly legible.	X	
Measuring units and ramps	Visual inspection: Components are damaged.	X	
Wiring	Visual inspection: Insulation is damaged.		X
Measuring units	Cleaning the interiors of the measuring units		X
Measuring units	Tighten screws on shear connectors.	X	
Measuring units	Adjust leg support.	X	
Adsorber	Check the condition of the drying agent.		X
Adsorber	Replace adsorber.	X	
Slide protection strip	Check the condition of the slide protection strip.		X
Slide protection strip	Replace the slide protection strip.	X	

Activate Maintenance Mode

1. Select **<Settings>**.
2. Select operation mode **Maintenance** in the **General information** tab.
3. Select **<Apply>**.

➡ The measuring unit lighting is turned off.

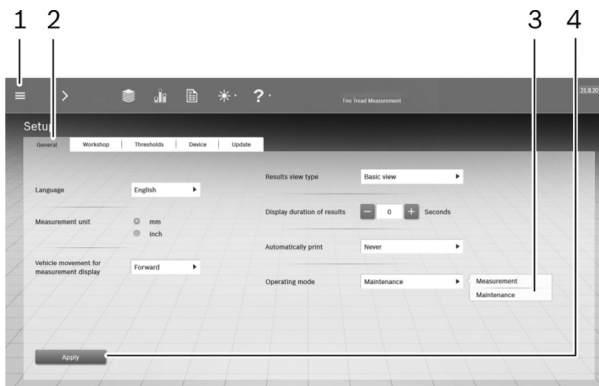

- 1 **<Settings>**
- 2 **General information** tab
- 3 **Maintenance** mode
- 4 **<Apply>**

Maintaining Measuring Units

1. Unhook drive-down ramps from measuring units: to do so, lift both fillister head screws of the drive-down ramps out of the measuring units' keyholes.

2. Open up the cover plates of the measuring units. Cover plate stays open by itself after it has been turned by approx. 110°.

3. Cleaning the internal spaces of the measuring units:

- Remove coarse material such as leaves and other small objects by hand.
- Remove small objects with a vacuum cleaner.

4. After cleaning the interior: Check clearance below the diagnosis modules with a feeler gauge. The **clearance must be approx. 1/16 inch (2 mm)**.

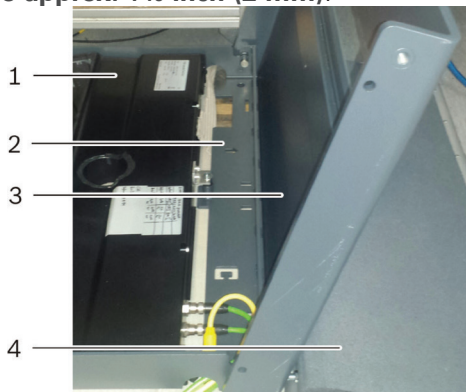

Fig. 4: Measuring Unit with Open Cover Plate
 1 Diagnostic module
 2 Frame
 3 Cover plate
 4 Drive-down ramp (unhooked)

5. Tighten screws of both measuring units on shear connectors.

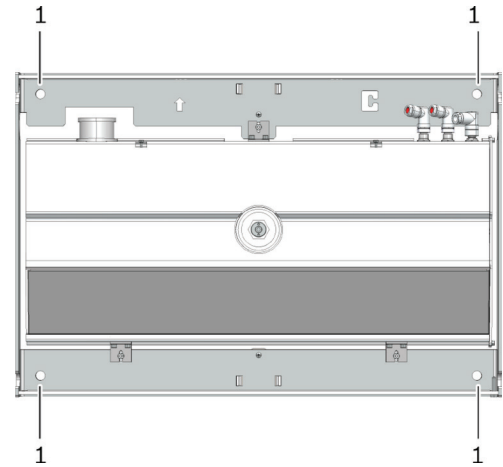

Fig. 5: Tighten Screws on Shear Connectors
 1 Screws/shear connectors

6. Re-adjusting support legs of both measuring units:

- Loosen the lock between the threaded bolt and two-hole nut.
- Turn the threaded bolt using a hex key until the cover plate rests equally on the frame and the leg support.
- Lock threaded bolt with two-hole nut.

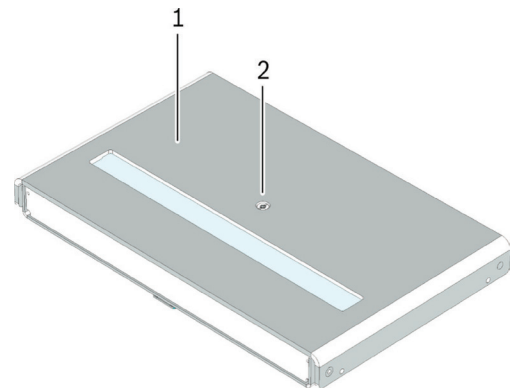

Fig. 6: Adjusting the Leg Support
 1 Cover plate
 2 Threaded bolt with two-hole nut

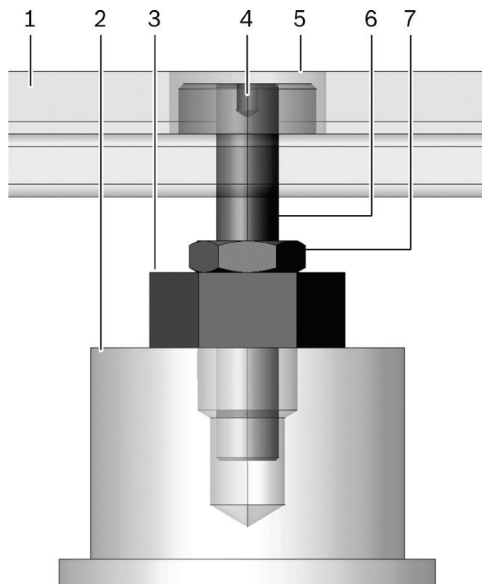

Fig. 7: Detail Central Support

- 1 Cover plate
- 2 Leg support
- 3 Hex nut SW27 M10
- 4 Two-hole nut
- 5 Threaded hole cover plate
- 6 Threaded bolt
- 7 Hex nut SW17 M10

- 7. Close cover plates.
- 8. Hinge drive-down ramps in measuring units.

Replacing Absorbers

1. Unhook drive-down ramps from measuring units: to do so, lift both fillister head screws of the drive-down ramps out of the measuring units' keyholes.

2. Open up the cover plates of the measuring units. Cover plate stays open by itself after it has been turned by approx. 110°.

3. Compare color of the drying agent with colors of the drying agent label.

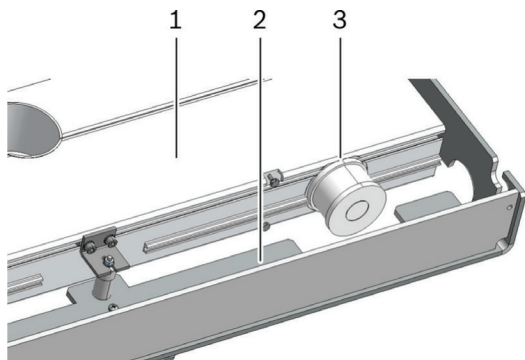

Fig. 8: Position Absorber

- 1 Diagnostic module
- 1 Frame
- 1 Absorber



Fig. 9: Absorber

- 1 Drying agent
- 2 Drying agent label

☐ Light grey drying agent: replace absorber.

- 4. Unscrew used absorber.
- 5. Unscrew protective cap of the new drying agent absorber.

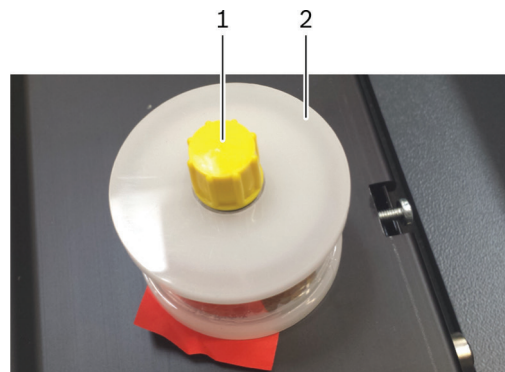

Fig. 10: Unscrewing the Protective Cap

- 1 Protective cap
- 2 Absorber

6. Screw new absorber in threaded hole of the measuring unit.

7. Attach new drying agent label to the top side of the absorber.

8. Remove absorber's red protective backing.



Do not remove protective backing until commissioning.

9. Close cover plates.

10. Hinge drive-down ramps in measuring units.

Replacing Slide Protection Strips

1. Remove displaced or worn slide protection strips from the cover plate.
2. Remove protective strip of the new slip protection strip.
3. Attach new slide protection strip to cover plate.

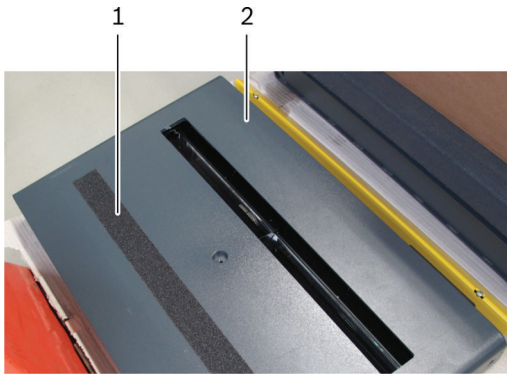

Fig. 11: Replacing Slide Protection Strips
1 Slide protection strip
2 Cover plate

Activating the Measurement Mode

1. Select **<Settings>**.
2. Select operation mode **Measurement in General information** tab.
3. Select **<Apply>**.

Disposal and Scrapping

- ☐ Dispose of adsorber in residual waste.

1. Disconnect the Tread Scanner from the mains and detach the power cord.
2. Dismantle the Tread Scanner and sort out and dispose of the different materials in accordance with the applicable regulations.



Tread Scanner, accessories and packaging should be sorted for environmental-friendly recycling.

- Do not dispose Tread Scanner into household waste.
- Dispose of used electrical and electronic devices, including cables, accessories and batteries, separately from household waste.
- Make use of the local return and collection systems for disposal.
 - Proper disposal of Tread Scanner prevents environmental pollution and possible health hazards.

Charging the Battery

1. Connect the module master and satellite to the power supply.
 2. Wait for 30 to 60 minutes.
 3. Switch off the Tread Scanner.
 4. Switch on the Tread Scanner.
- ☐ See section 8.2 Settings for steps 5–7:
 - General information
 - Device
 - 5. Enter password.
 - 6. Apply the browser's system date and time.
 - 7. Apply the browser's time zone.
- ➔ "Apply":
- ☐ The device must be connected for approx. 12 hours for a full battery charge.

Error Codes

Errors without Error Number

Description	Possible cause	Check	Measure
Faulty or no measurement	Measuring instrument dirty	Check measuring instrument for cleanness.	Clean the measuring instrument, repeat the measurement Contact customer service, if still no or faulty measurement is possible after the instrument has been cleaned.
	Glass plate damaged	Visual inspection	Switch off the measuring unit and contact Customer Service.
	Glass plate fogged or dirty	Visual inspection	Selecting overall page width or overall page height view
	Malfunction of the lighting (lighting does not flash 30 seconds after it has been switched on)	Have all plugs been plugged up correctly? Are the M12 plugs of the voltage supply tightly screwed into the measuring units? Are the M12 plug contacts bent?	Disconnect measuring units from the power supply Wait 10 seconds. Re-connect power supply of both measuring units simultaneously. Wait 30 seconds. Contact Customer Service if the lighting still does not flash following the inspection.
Results of measurement are not displayed	Crossing too fast	Cross the device more slowly.	Contact customer service if the measurement results are still not displayed after crossing the device again.

Overview of Error Numbers

☒ For all other failure indications: contact customer service at 800-688-6359.

Error No.	Meaning	Measures
1000	Faulty crossing.	Repeat crossing
1001	The vehicle was driving too slow.	Repeat crossing; drive faster
1002	The vehicle was driving too fast.	Repeat crossing; drive slower
1010	Crossing took place too far on the left.	Repeat crossing; drive in the center
1011	Crossing took place too far on the right.	Repeat crossing; drive in the center
1012	The track width is too small.	Vehicle cannot be measured
1013	The track width is too large.	Vehicle cannot be measured
1014	No valid vehicle.	Repeat crossing
1015	Wrong direction of travel.	Repeat crossing in the other direction
1016	Tire is too narrow or did not pass over the measurement window with its entire width.	Tire cannot be measured Drive across once more, keep to center
1017	The tire is too wide.	Tire cannot be measured
1100	Not enough measurement results.	Repeat crossing
1101	No measurement results.	Repeat crossing
2001	Command or function not implemented.	Contact customer service
2002	Query contains invalid XML data.	Contact customer service
2003	Reading the statistics file failed.	Contact customer service
2004	Processing of command failed.	Contact customer service
2005	Reading the temperature failed.	Contact customer service
2006	Communication with the remote module not possible.	Check wiring and network connection
2007	Communication with the state controller not possible.	Restart, contact customer service
2008	It is not permitted to switch the operation mode.	Information only
2109	Switching the operation mode not possible.	Restart, contact customer service
2110	The device is in ERROR mode. It cannot be measured.	Information only
2111	The device is in READY/UPDATE mode. It cannot be measured.	Information only
2112	Format of query is invalid.	Format of query is invalid.

Error No.	Meaning	Measures
2113	Query not allowed.	After entering password, repeat entry with correct password. Otherwise, information only.
2114	Requested resource not available.	Contact customer service
2115	Query is too large.	Contact customer service
2116	Master and Satellite cannot have the same IP address.	Correct entry
2117	This IP address cannot be changed as long as the other address is not left blank.	Correct entry
2118	Invalid IP address.	Correct entry
2119	Invalid date/time format.	Contact customer service
2120	Writing the branding file failed.	Contact customer service
2121	Setting of illuminance failed.	Restart measuring units; call customer service if fault persists
2122	Master and Satellite have different versions.	Match software versions of Master and Satellite
2123	Invalid password.	Use the right password
3000	CPU temperature too high.	Inappropriate test conditions; switch set-up location
3001	CPU temperature too low.	Inappropriate test conditions; switch set-up location
3002	The illumination has switched itself off due to an object permanently present over the measurement window or is defective.	Remove object from measurement window; Restart measuring units; call customer service if fault persists
3003	No network connection between Master and Satellite.	Check wiring and network connection
3004	At least one sensor is not connected correctly or is defective.	Restart measuring units; contact customer service if fault persists.
3005	Unspecific hardware fault.	Restart measuring units; contact customer service if fault persists.
3006	The battery for the RTC component is discharged.	Connect module to electricity, see chap. 7.4.3
3007	Satellite cannot reach master.	Check configuration, wiring and network connection.
3008	Master cannot reach satellite.	Check configuration, wiring and network connection.
3009	Humidity is too high.	Inappropriate test conditions; switch set-up location
3010	Moisture is higher than usual.	Inappropriate test conditions; switch set-up location
4000	Invalid configuration.	Contact customer service
4001	Loading the configuration failed.	Contact customer service
4002	Loading the calibration failed.	Contact customer service; recalibrate
4003	Writing the module configuration failed.	Restart, contact customer service
4004	Set IP address of the master does not match the IP address of the module.	Correct wrong network configuration
4005	Set IP address of the satellite does not match the IP address of the module.	Correct wrong network configuration
4006	Invalid module ID.	Correct wrong configuration
4007	No IP address configured for the satellite.	Correct wrong network configuration
4008	No IP address configured for the master.	Correct wrong network configuration
5000	Poor display quality.	Repeat crossing
5001	The surroundings are too bright.	Inappropriate test conditions; switch set-up location
5002	The measurement window is too dirty.	Clean
5003	Too much scattered light.	Inappropriate test conditions; switch set-up location
5004	Too much extraneous light.	Inappropriate test conditions; switch set-up location
20480	An error occurred.	Re-start measuring units; contact customer service if fault persists
20481	Missing or invalid response from measurement system.	Re-start measuring units; contact customer service if fault persists
20482	Update installation failed.	Re-start measuring units; contact customer service if fault persists
20483	No measurement data available.	Re-start measuring units; contact customer service if fault persists
20484	The device is not ready for operation. Please restart the measuring units.	Re-start measuring units; contact customer service if fault persists

Software Configuration

Starting the System

1. Switch on the power supply for the measuring units at the electrical cabinet.

➤ After 30 seconds, the lighting of both measuring units **must flash 3 times, and then stay lit.**

➡ This means that the device is ready for operation.

2. Switch on display system (PC/ Smart TV/ Tablet).

3. Start the web browser.

➤ The home page of the Tread Scanner software is displayed automatically, provided that it has been set as the home page beforehand.

📖 If the Tread Scanner software has not been set as the home page: Enter IP address of the "Master" measuring unit in address input box (default IP address: 192.168.10.10).

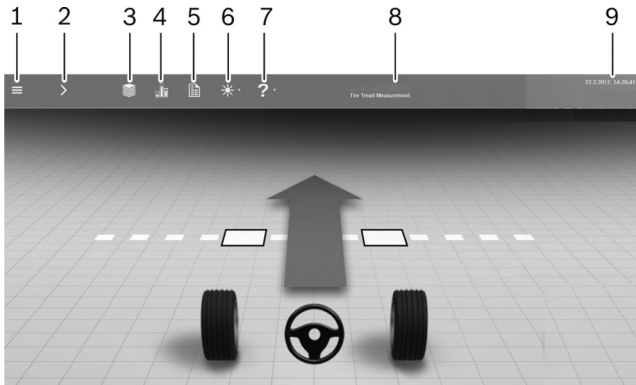

No.	Screen element	Description
1	Settings	Switch to the settings menu
2	Crossing	Switch to crossing mode
3	Process	Switch to process display
4	Statistics	Switch to statistical evaluation
5	Record	Switch to crossing protocol
6	Type of tire	Selection of tire type (summer/ winter tires) Determining the starting thresholds: see sec. 8.2.3
7	Help	Link to the original operating instructions, initial-commissioning instructions and open-source licenses
8	Version number	Displaying the software version number
9	Date / Time	Displaying date and time

Settings

The following tabs are available in the settings menu: **General Information, Workshop, Thresholds, Device, Update.**

General information

Adjust general settings.

1. Select <Settings>.

2. Enter password: **ttm#admin**

3. To save changes: Select <Apply>.

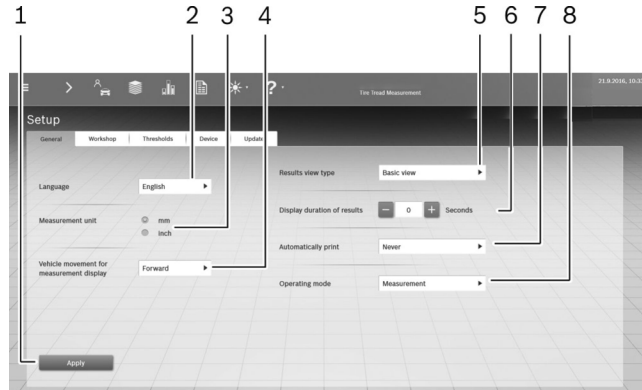

No.	Screen element	Description
1	Apply	Saving changed settings.
2	Language	Language selection
3	Unit of measurement	Selecting the unit of measurement: mm or inch
4	Vehicle movement for measurement display	Selection of vehicle movement: forwards, backwards, forwards and backwards
5	Display duration of results	Setting the display duration of results (in seconds). Entering "0": measurement results are constantly displayed until the next crossing is started.
6	Automatic printing	Selection of when a crossing protocol shall be printed automatically: never, below the thresholds or always
7	Mode	Mode selection: measurement or maintenance
8	Direction of travel	Display of measured values with selected directions of travel.

Workshop

Enter and edit workshop information.

➤ Save changes with <Apply>.

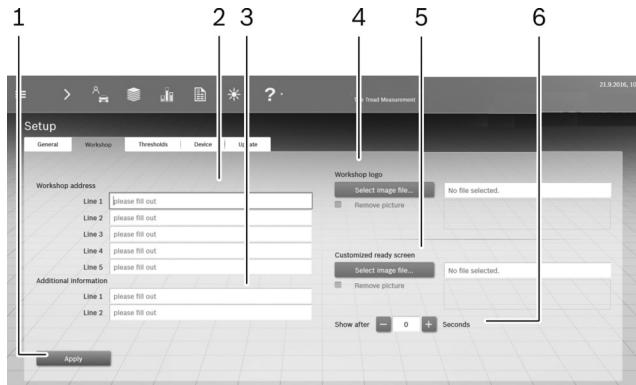

No.	Screen element	Description
1	Apply	Saving changed settings.
2	Workshop address	Entering the workshop address.
3	Additional information	Entering additional information.
4	Workshop logo	Selecting and uploading the workshop logo.
5	Individual standby	Selecting and uploading the individual standby.
6	Display after	Set the number of seconds upon successful measurement after which stand-by shall be displayed. Individual stand-by is not displayed if "0" has been entered or no image file has been uploaded.

Thresholds

Enter and edit thresholds.

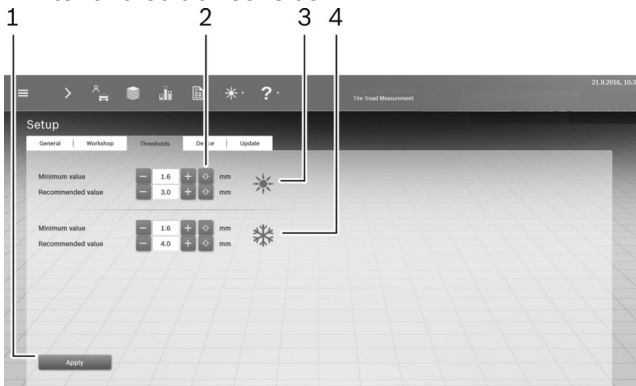

➤ Save changes with <Apply>.

No.	Screen element	Description
1	Apply	Saving changed settings.
2	0	Changing a threshold to "0".
3	☀️	Entering the minimum and recommended threshold for summer tires.
4	❄️	Entering the minimum and recommended threshold for winter tires.

☐ Minimum threshold "0": only the recommended threshold is considered in the result display. The results are highlighted green or yellow (see chap. 8.3).

Recommended threshold "0": only the minimum threshold is considered in the result display. The results are highlighted green or red (see chap. 8.3).

Both thresholds "0": no threshold is considered in the result display. All results are displayed in the color of the standard text. The input boxes in the "simple view" result display remain white (see chap. 8.3).

Device

Enter and edit Tread Scanner information.

➤ Save changes with <Apply>.

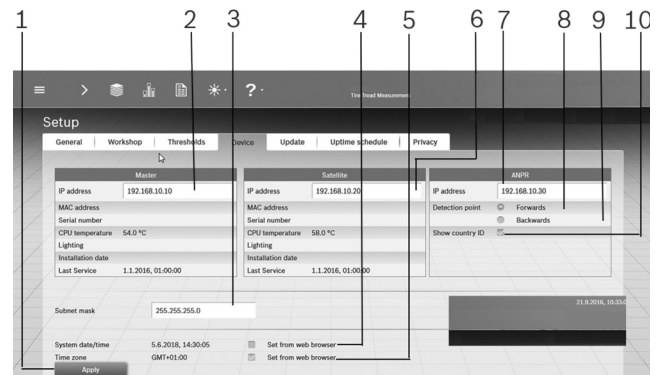

No.	Screen element	Description
1	Apply	Saving changed settings
2	Master	Entering the IP address of the "Master" measuring unit
3	Subnet mask	Entering the subnet mask
4	System date and time	Selecting Adopt from browser option
5	Time zone	Selecting Adopt from browser option
6	Satellite	Entering the IP address of the "Satellite" measuring unit
7	ANPR IP address	Entering the measuring unit "ANPR"
8	Recording direction forwards	The ANPR camera has been installed in such way that the registration number is recorded prior to measuring the tread depth.
9	Recording direction backwards	The ANPR camera has been installed in such way that the registration number is recorded after measuring the tread depth.
10	Displaying the country ID	ANPR system transmits country ID the display of which is switched on or off.

Update

Update the software.

1. Set the maintenance mode on the Master.
2. Start update on Satellite.
3. Start update on Master.
4. Restart.

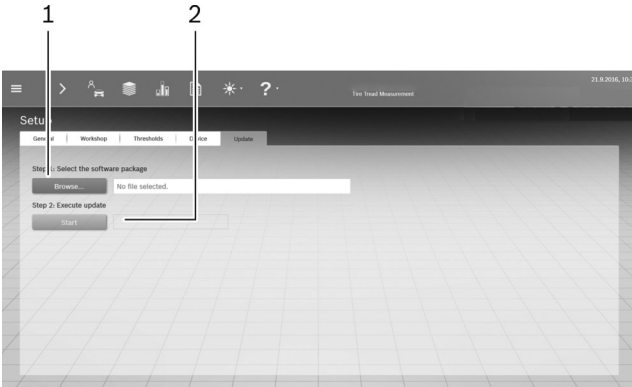

No.	Screen element	Description
1	Browse	Selecting and loading a software update file
2	Start	Starting the update process

Operating Time

Set the time and assign weekdays.

➤ Save changes with <Apply>.

- ❑ If the Tread Scanner modules are always activated; it is reasonable to limit the stand-by mode to the actual daily usage. This increases the service life of the device.

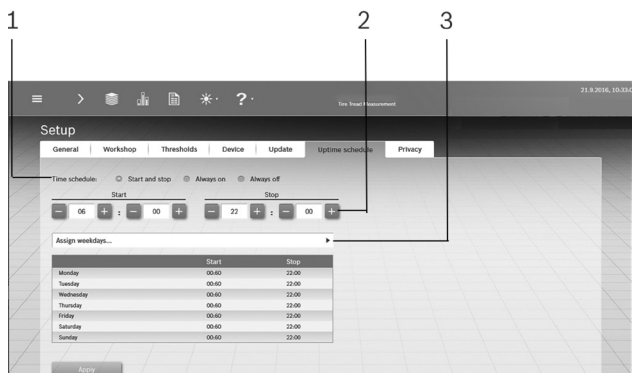

No.	Screen element	Description
1	Schedule	Select the schedule
2	Time	Set the time
3	Week days	Assign week days

Data Protection

➤ Save changes with <Apply>.

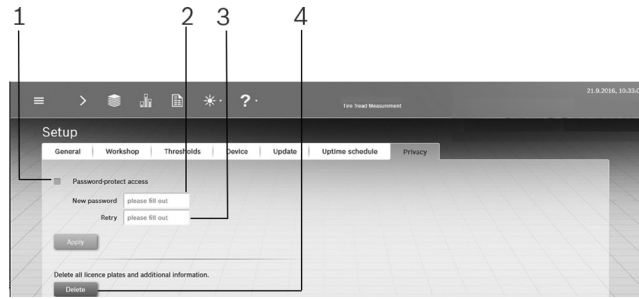

No.	Screen element	Description
1	Protect access with password	Protect access with password: activate
2	New password	Enter new password
3	Repeat	Repeat new password
4	Delete	Delete all registration numbers and information

- ❑ Password is required when calling up the software. Access to the software is only possible after the password has been entered.

Forgot Your Password

If you forgot your password, the existing password can be deleted by using the link "Forgot your password?" and entering the administrator password. Due to data protection reasons, also all stored vehicle data (registration number, additional information) were deleted.

Deleting Registration Numbers and Information

All registration numbers automatically recorded via the ANPR system as well as those entered manually on the "Test protocol" page and additional information can be deleted. Deleting the information must be confirmed by entering the administrator password.

Display of Measurement Results

The measurement results is automatically displayed some seconds after the crossing.

- ❑ If the Tread Scanner was delivered together with the ANPR camera, the registration number is displayed in all views as an additional feature.

Standard View

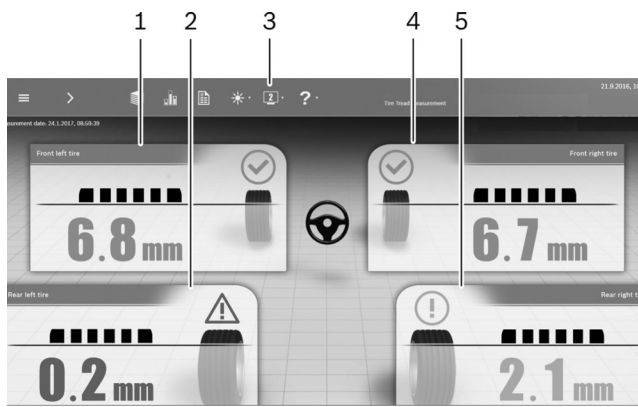

No.	Screen element	Description
1	Front Left	Tread depth measurement result front left tire
2	Rear Left	Tread depth measurement result rear left tire
3	Type of result display	1: Simple view, 2: standard view, 3: extended view Type of result display is determined in the "Settings" menu, and can be changed temporarily while the result is displayed.
4	Front Right	Tread depth measurement result front right tire
5	Rear Right	Tread depth measurement result rear right tire

Simple View

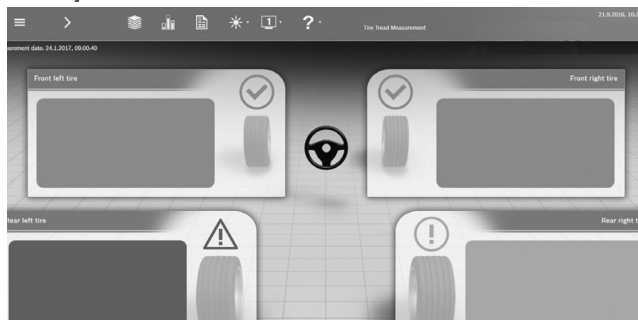

Extended View

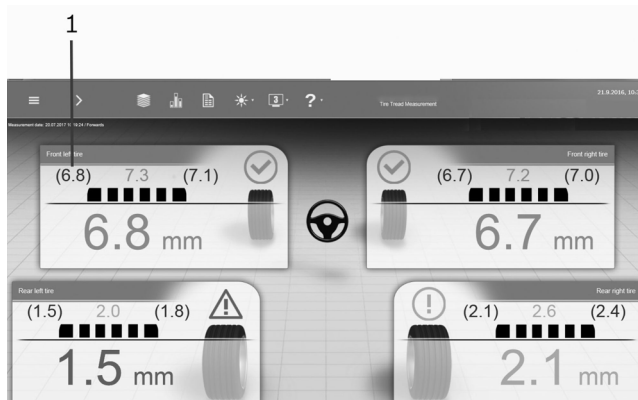

1 Guiding values in brackets

□ Guiding values in brackets are displayed if the measurement cannot be performed correctly.

Examples:

Guiding values in brackets	Remedy
Tires too small	—
Run-over speed too high	Decrease run-over speed
Too much humidity on the tire	Dry tires
Too much humidity on the glass plate	Dry glass plate
Direct and strong sunlight	Shade the measurement bay

Interpretation of measuring results

No.	Description	Icon
1	Green writing or green input box and green checkmark: Tread depth is sufficient, tire must not be replaced.	
2	Yellow writing or yellow input box and yellow exclamation mark: Tread depth is still sufficient, tire should be replaced soon.	
3	Red writing or red input box and red warning sign: Tread depth is insufficient, tire must be replaced.	

Process and Test Protocol

The process display lists the past 10 crossings. The test protocol shows the results of a selected crossing.

1. Select <Process>.
2. Highlight a line and select <Protocol>.



No.	Screen element	Description
1	Process	Switch to process display
2	Record	Switch to crossing protocol

➡ Protocol of the selected crossing is displayed.

3. Set protocol view preferences.

- Select right button to view the overall protocol width.
- Select left button to view the overall protocol height.

4. Select **<Print>** to print the protocol (requires access to printer).

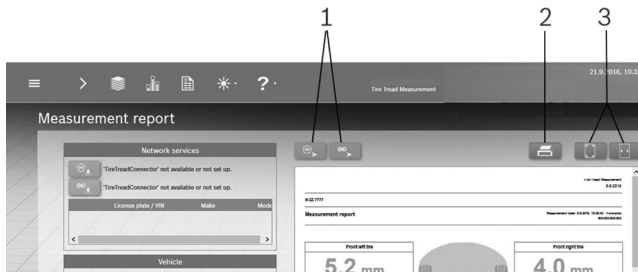

No.	Screen element	Description
1	Protocol view	Selecting overall page width or overall page height view
2	Print	Printing the displayed protocol
3	Protocol view	Selecting overall page width or overall page height view

! To print the result output: activate background print in the browser's printer settings (see browser online help).

Statistics

The statistical evaluation of the measured tread depth is displayed as a diagram for the selected period of time.

1. Select **<Statistics>**.
2. Enter password: **ttm#admin**
3. Select or enter period of time.
4. Select **<Apply>**.
5. Select **<Download statistics data>** if you want to save the file.

! The statistical data contain travels from both directions independent of the "Direction of travel" setting.

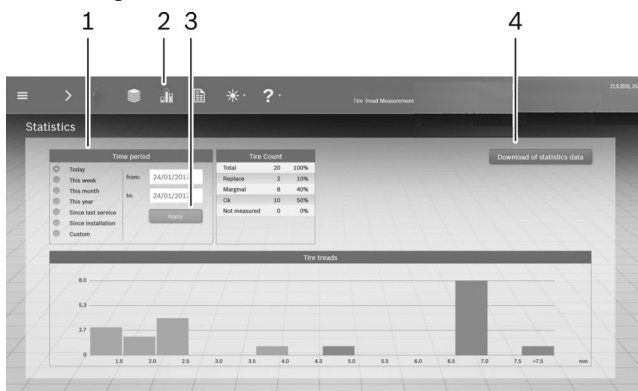

No.	Screen element	Description
1	Period	Selecting the time period
2	Statistics	Switch to statistical evaluation
3	Apply	Saving changed settings
4	Downloading statistical data	Saving the displayed statistical data

Vehicle Data

Entering Vehicle Data

In the "Test protocol" view, data can be directly entered or copied from existing orders.

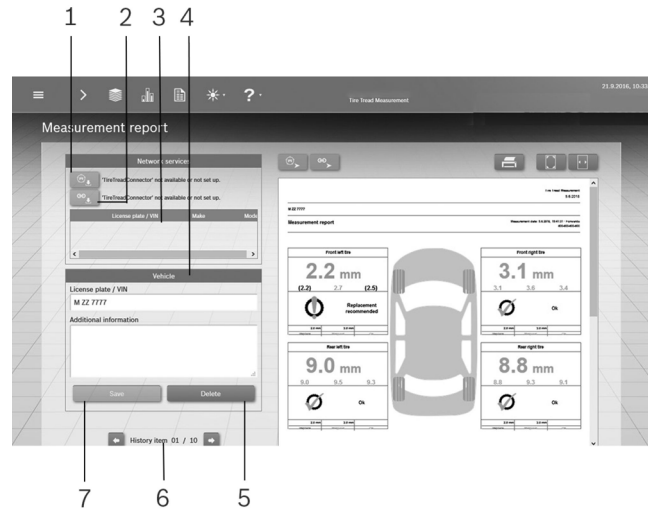

No.	Screen element	Description
1	Button "CoRe"	Calling up orders via "Connected Repair".
2	Button "Entrance Check"	Calling up orders via "Entrance Check".
3	Orders	List of available orders.
4	Vehicle data	Enter registration number and additional information or copy from orders. If ANPR is available here, the registration number is entered automatically.
5	Button "Delete"	Registration numbers and additional information regarding the currently displayed measurement results are deleted. Deleting the information must be confirmed by entering the administrator password.
6	Selecting the progress entry	The progress can be paged through by using both arrow buttons.
7	Button "Save"	Manually entered or called up data regarding the currently displayed measurements results are saved.

Direct Data Entry

1. Select **<Test protocol>**.
2. Entry in the input box "Registration number /VIN" or "Additional information".
3. Select the button **<Save>**.

Copying Data from Orders

Open orders can be called up via “Connected Repair” or “Entrance Check”.

1. Select <Test protocol>.
2. Select button in the “Connected Repair” or “Entrance Check” section. Button is only active if service is available via the network.

❑ If a service is unavailable, a status message is displayed: Possible causes are a faulty configuration of the “Tire Tread Connector” or a network problem.

➡ The order list is displayed.

❑ A message is displayed for both success or failure.

3. Select the desired order from the list.

➡ Selected vehicle data of that order are copied in the input boxes.

4. Select the button “Save”.

Copying Measurement Results

In the “Test protocol” view, vehicle data can be linked to a measurement result to the “Connected Repair” or the “Entrance Check” service.



No.	Screen element	Description
1	Button “CoRe”	Data transfer to “Connected Repair”
2	Button “Entrance Check”	Data transfer to “Entrance Check”

Transferring Data to “Repair Workshop”

➤ Select button for transfer (no. 1).

❑ The button is only active if the data has been saved in the “Test protocol” view.

➡ The data is transferred to “Connected Repair”. If the transfer has been successful; a green checkmark appears. In case of errors, a red exclamation mark, and an error message, if applicable, appears.

Transferring Data to “Entrance Check”

➤ Select button for transfer (no. 2).

❑ The button is only active if the data has been saved in the “Test protocol” view.

➡ The data is transferred to “Entrance Check”. If the transfer has been successful; a green checkmark appears. In case of errors, a red exclamation mark, and an error message, if applicable, appears.

Technical Data

Technical Data Specifications

System Data

Function	Specification
Dimensions H x W x D (without vehicle access)	3 ¼ x 88 ⅜ x 41 (82 x 2245 x 1040 mm)
Measurement principle	Global tread depth measurement with light triangulation
Output value	The most common local tread depth
Measurement accuracy	+/- .010 mm (+/-0,25 mm)
Measuring range	middle 75% of the tire
Duration of diagnostics	<5 seconds
Allowance parallelism in direction of travel	+/- 7/8 inch (+/- 20 mm)
Allowance rotation in direction of travel	+/- 7/8 inch
Maximum permissible list	5%

Temperature and Working Environment

Function	Specification
Working temperature / Function range	-13 °F to + 113 °F (-25 °C to +45 °C)
Storage temperature	-13 °F to +140 °F (-25 °C to +60 °C)
Maximum humidity	95%
Maximum operating altitude	7,200 feet above sea level (2200 m ü.N. N.)
Minimum floor load-bearing capacity	4,350 PSI (30 N/ mm ²)

Electrical Data

Function	Specification
Power Supply	110 V, 15 A 50-60 Hz 1-phase
System performance	200 W
Maximum distance of transfer points Voltage supply Network	<ul style="list-style-type: none"> • 33 feet (10 m) • 33 feet (10 m), optional 66 feet (20 m)
Degree of protection of diagnostic modules	IP65
Degree of protection switch, cable extensions, data cable, TV, etc.	n.a.
Dimensions electrical cabinet	15.2 x 9.2 x 6 inches (387 x 234 x 150.8 mm)

