



HEAVY-DUTY 2-POST LIFTS

CL16 & CL20 SERIES SITE SPECIFICATIONS

BAY HEIGHT: 13'8" minimum

BAY WIDTH: 14', 14'6", 15' respectively*

BAY DEPTH: 28' minimum

POWER REQUIRED: 3HP, 1PH, 60HZ, 208/230V

MIN. CONCRETE SPEC: 4" thick, reinforced, free from cracks/seams, rated at 3500+ psi, cured at least 28 days

SERVICE BAY LAYOUT

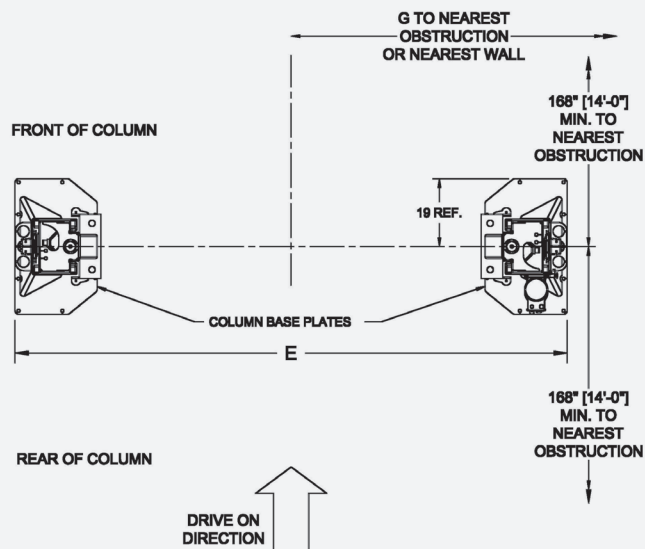

Model Number	CL16-0-3S			CL16-2-3S			CL20-0			CL20-2		
Description	16K Standard			16k Extended Height			20K Standard			20K Extended Height		
Lifting Capacity ¹	16,000 lbs.			16,000 lbs.			20,000 lbs.			20,000 lbs.		
Lift Configuration	Symmetric			Symmetric			Symmetric			Symmetric		
Arm Configuration	3-Stage Front/Rear			3-Stage Front/Rear			2-Stage Front/Rear			2-Stage Front/Rear		
Max Load Per Arm ¹	4,000 lbs.			4,000 lbs.			5,000 lbs.			5,000 lbs.		
A Overall Height Options <small>Standard, -6", -12"</small>	174"	168"	162"	198"	192"	186"	174"	168"	162"	198"	192"	186"
Ceiling Height Required	176"	170"	164"	200"	194"	188"	176"	170"	164"	200"	194"	188"
B Floor to Overhead Switch	167"	161"	155"	191"	185"	179"	167"	161"	155"	191"	185"	179"
C Rise Height <small>Max. with Stack Adapters</small>	Min. 75.5" Max. 81.5"			Min. 75.5" Max. 81.5"			Min. 76.6" Max. 84.6"			Min. 76.6" Max. 84.6"		
D Screw Pad Height	Min. 4.75" Max. 6.5"			Min. 4.75" Max. 6.5"			Min. 6.2" Max. 7.6"			Min. 6.2" Max. 7.6"		
Stack Adapter Heightq	3" & 6"			3" & 6"			4" & 8"			4" & 8"		
E Overall Width Options <small>Standard, -6", -12"</small>	166.75"	160.75"	154.75"	166.75"	160.75"	154.75"	166.75"	160.75"	154.75"	166.75"	160.75"	154.75"
F Between Columns	132"	126"	120"	132"	126"	120"	132"	126"	120"	132"	126"	120"
*G To Nearest Obstruction <small>Standard, -6", -12"</small>	7'6"	7'3"	7'	7'6"	7'3"	7'	7'6"	7'3"	7'	7'6"	7'3"	7'
Drive-Thru Clearance	116.25"	110.25"	104.25"	116.25"	110.25"	104.25"	116.25"	110.25"	104.25"	116.25"	110.25"	104.25"
Arm Reach	Min. 36.625" Max. 75"			Min. 36.625" Max. 75"			Min. 38.5" Max. 62"			Min. 38.5" Max. 62"		
Motor / Voltage ²	3HP, 1Ph, 60Hz, 208/230v			3HP, 1Ph, 60Hz, 208/230v			3HP, 1Ph, 60Hz, 208/230v			3HP, 1Ph, 60Hz, 208/230v		
Air Supply Required	90-120 psi			90-120 psi			90-120 psi			90-120 psi		
Rise Time ³	62 s			62 s			62 s			62 s		
ALI Certified	✓											
Available Colors	■ ■ ■											

¹ Lift capacity ratings are based on loads equally distributed on all four arms.

² Optional 3 phase electrical also available.

³ Lifting and lowering speeds may vary depending on the weight of the vehicle.