

CEMB[®] USA



C212

A multi-function HD truck wheel balancer with LED display and built-in wheel lift. Easily balances all light duty, medium duty, commercial and heavy-duty truck wheel applications. Extremely accurate with a simple to use interface. An excellent choice for tire dealers, fleet repair shops, municipalities handling a wide array of commercial vehicles.

C212

Simple To Use Interface

Average Cycle Time

Direct Weight Location

Built In Wheel Lift

Button Activated Brake

Automatic 2D Inner Data Arm



Standard Accessories



40FF51334



40FF51315



40FF79260

Manual Locking Kit
41FF59322



40FF61043



40FF43716



40FF43715



40FF88351

Cones



40FF43745



940010105

4-Piece Truck Con Kit
40FF43748K



40FF52417
3.8" - 6.7" (97 - 170mm)



40FF43746
7.3" - 8.7" (202 - 221mm)



Weight Hammer
301400525



Rim Width Gauge
940051000

DIMENSIONS

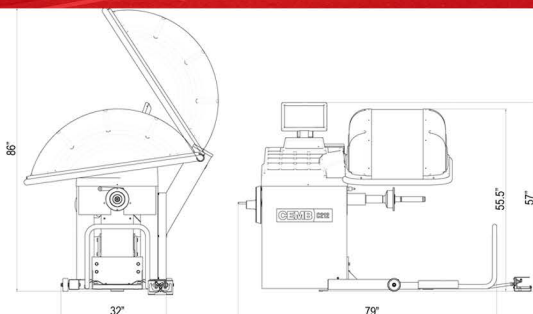

Power Supply:	220V + AIR
Wheel Clamping Type:	Manual
Max. Rim Diameter:	30" (765 mm)
Max. Rim Width:	20" (510 mm)
Max. Tire Diameter:	51" (1295 mm)
Max. Wheel Weight:	550 lbs. (250 kg)
Shipping Weight:	660 lbs. (300 kg)

CONTACT

CEMB[®] USA

CEMB USA - BL Systems Inc.
2873 Ramsey Road, Gainesville, GA 30501
(678) 717-1050 - sales@cemb-usa.com
www.cemb-usa.com

(678) 717-1050

www.cemb-usa.com

2873 Ramsey Road, Gainesville, Georgia

