

PARTS BREAKDOWN (continued)
Fig E. Carriage & Arms

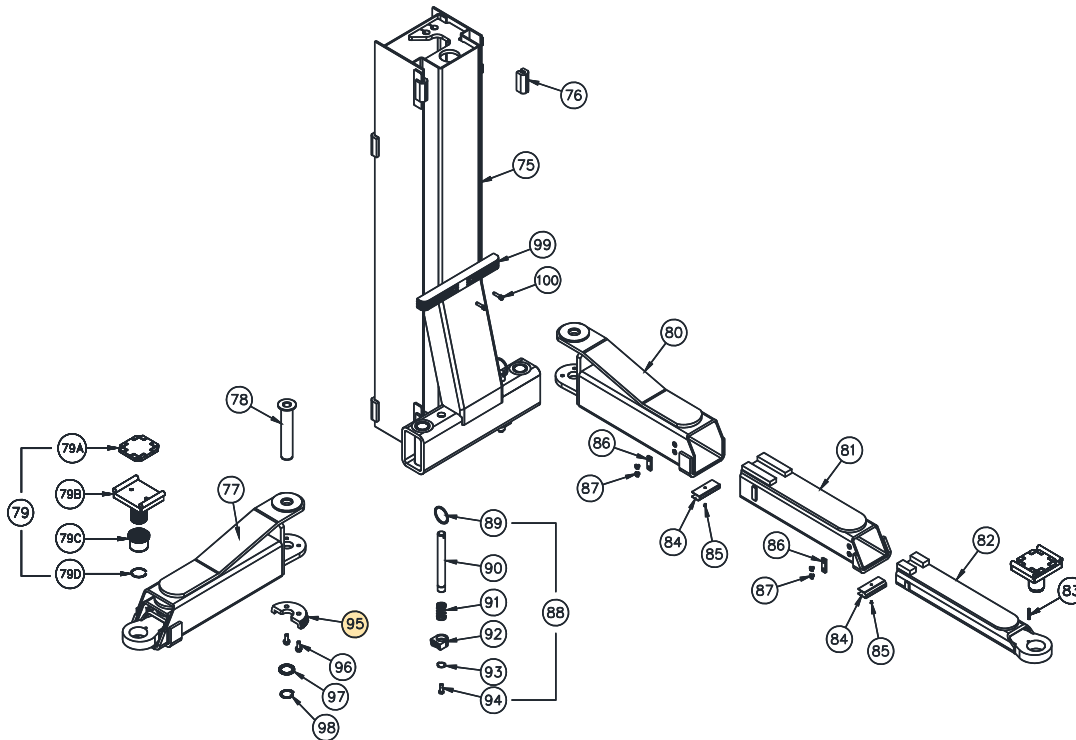

ITEM #	PART #	QTY/LIFT	DESCRIPTION
75	B12621	2	CARRIAGE WELD
76	31023	16	SLIDE BLOCK ASSEMBLY
77	B12800B	4	3-STAGE ARM ASSEMBLY (includes Items 78 thru 87)
78	B12544	4	ARM PIN WELD
79	B12162S-12	4	FOOT PAD ASSEMBLY – 12K
79A	A1104-H	4	Pad
79B	B12163S	4	ADAPTER PAD WELD
79D	B17276-1	4	ADAPTER BASE
79E	B17257	4	3 x 45mm RETAINING RING
80	B12801	4	FEMALE ARM WELD
81	B12802	4	INTERMEDIATE ARM WELD
82	B12803	4	MALE ARM WELD
83	B2211	4	ROLL PIN-Ø6 x 30mm Lg.
84	B12805	8	ARM SHIM
85	B12807	8	M6x6 BUTTON HEAD CAP SCREW
86	3W-04-18	8	STOP BLOCK
87	17350	16	M8x10 FLAT HEAD BOLT, CL8.8
88	A1077TC-12	4	ARM RESTRAINT SHAFT ASSEMBLY (includes items 89 thru 94)
89	A1075	4	PULL RING
90	12583	4	ARM RESTRAINT SHAFT
91	31109	4	COMPRESSION SPRING
92	A1072TC	4	OUTER GEAR
93	36014	4	1" EXTERNAL RETAINING RING
94	12568	4	3/8-16NC HEX FLANGE HEAD CAP SCREW
95	A1070TC	4	INNER GEAR
96	B1068	8	M10x25 HEX FLANGE HEAD BOLT
97	B2203S-01D	4	39mm ID, 51mm OD Washer
98	B1083	4	38mm External Retaining Ring
99	B2026-2	2	DOOR GUARD
100	X10-088	4	M8 x 1.25 x 30mm SHCS

Replace all worn, damaged, or broken parts with parts approved by **Challenger Lifts Inc.** or with parts meeting **Challenger Lifts Inc.** specifications.
Contact your local Challenger Lifts Parts Distributor for pricing and availability.
(Call **Challenger Lifts Inc.** (502) 625-0700 for the Parts Distributor in your area)