

COATS®

885 Wheel Balancer



See
★ **Balancing Your
First Tire**
on page 1.

Safety Instructions Set Up Instructions Operation Instructions Maintenance Instructions

READ these instructions before placing unit in service. KEEP these and other materials delivered with the unit in a binder near the machine for ease of reference by supervisors and operators.

HENNESSY
INDUSTRIES



NOTICE

Read entire manual before assembling, installing, operating, or servicing this equipment.

Table of Contents

Important Safety Instructions.....iv - vi	Setup.....16
Owner’s Responsibility.....v	Menu Access Diagram.....16
Operator Protective Equipment.....v	Self-Diagnostics.....17
Definitions of Hazard Levels.....v	Balancing Machine Calibration.....17
Safety Notices and Decals.....vi	Automatic Gages Calibration.....18
Standard Safety Devices.....vi	Distance Gauge Calibration.....18
*Balancing Your First Tire.....1	Diameter Gauge Calibration.....19
Principle Operating Parts.....2	Adhesive Weight Width.....20
Know Your Unit.....2	Diagnostics.....21
Power Switch.....3	Inconsistent Unbalance Readings.....21
Operating the Balancer.....4	Alarm Signal.....21
Wheel Mounting.....4	Installation Instructions.....23
Standard Back Cone/Collet Mounting.....4	Receiving.....23
Optional Front Cone/Collet Mounting.....5	Standard Accessories.....23
Alternate Mounting.....5	Features.....23
Control Panel And Display.....6	Specifications.....23
Operation Functions Menu.....7	Electrical Requirements.....23
Use of the Wheel Balancer.....7	Floor and Space Requirements.....24
Standard Balancing (clip-on weights).....7	Unpacking the Unit.....25
Wheel Dimensions Setting.....7	Remove Balancer from Pallet.....25
Result of the measurement and	Connect to Power.....25
weight application.....9	Initial Testing.....25
Balancing with Adhesive Weights (ALU).....10	Hood Installation.....25
Wheel Dimensions Setting.....10	
Result of the measurement and	
weight application.....11	
Balancing With A Mix Of Adhesive and	
Clip-On Weights and Static Balancing....12	
Static Unbalance.....13	
Exact Positioning of the Adhesive Weight	
By Means Of The Gauge With Clips.....13	
Hide The Adhesive Weights (Behind Spoke).....14	
Automatic Minimization Of Static Unbalance...14	
Unbalance Match Mount Balance.....15	

IMPORTANT SAFETY INSTRUCTIONS

READ ALL INSTRUCTIONS

1. Eye and face protection recommendations:
“Protective eye and face equipment is required to be used where there is a reasonable probability of injury that can be prevented by the use of such equipment.” O.S.H.A. 1910.133(a) Protective goggles, safety glasses, or a face shield must be provided by the owner and worn by the operator of the equipment. Care should be taken to see that all eye and face safety precautions are followed by the operator. ALWAYS WEAR SAFETY GLASSES. Everyday glasses only have impact resistant lenses, they are not safety glasses.
2. Be sure that wheels are mounted properly, the hub nut engages the arbor for not less than four (4) turns, and the hub nut is firmly tightened before spinning the wheel.
3. Read and understand this manual before operating. Abuse and misuse will shorten the functional life.
4. Be sure the balancer is properly connected to the power supply and electrically grounded.
5. Do not operate equipment with a damaged cord or if the equipment has been dropped or damaged – until it has been examined and repaired by a qualified serviceman.
6. Do not let cord hang over edge of table, bench, or counter or come in contact with hot manifolds or moving fan blades.
7. If an extension cord is necessary, a cord with a current rating equal to or more than that of the equipment should be used. Cords rated for less current than the equipment may overheat. Care should be taken to arrange the cord so that it will not be tripped over or pulled.
8. Keep guards and safety features in place and in working order.
9. Wear proper clothing. Safety toe, non-slip footwear and protective hair covering to contain hair is recommended. Do not wear jewelry, loose clothing, neckties, or gloves when operating the balancer.
10. Keep work area clean and well lighted. Cluttered and/or dark areas invite accidents.
11. Avoid dangerous environments. Do not use power tools or electrical equipment in damp or wet locations, or expose them to rain.
12. Avoid unintentional starting. Be sure the balancer is turned off and power disconnected before servicing.
13. Disconnect the balancer before servicing.
14. Use only manufacturer’s recommended accessories. Improper accessories may result in personal injury or property damage.
15. Repair or replace any part that is damaged or worn and that may cause unsafe balancer operation. Do not operate damaged equipment until it has been examined by a qualified service technician.
16. Never overload or stand on the weight tray or any part of the balancer.
17. Do not allow untrained persons to operate machinery.
18. To reduce the risk of fire, do not operate equipment in the vicinity of open containers or flammable liquids (gasoline).
19. Adequate ventilation should be provided when working on or operating internal combustion engines.
20. Keep hair, loose clothing, fingers, and all parts of body away from moving parts.
21. Use equipment only as described in this manual.
22. Use only manufacturer’s recommended attachments and accessories.

SAVE THESE INSTRUCTIONS

Owner's Responsibility

To maintain machine and user safety, the responsibility of the owner is to read and follow these instructions:

- Follow all installation instructions.
- Make sure installation conforms to all applicable Local, State, and Federal Codes, Rules, and Regulations; such as State and Federal OSHA Regulations and Electrical Codes.
- Carefully check the unit for correct initial function.
- Read and follow the safety instructions. Keep them readily available for machine operators.
- Make certain all operators are properly trained, know how to safely and correctly operate the unit, and are properly supervised.
- Allow unit operation only with all parts in place and operating safely.
- Carefully inspect the unit on a regular basis and perform all maintenance as required.
- Service and maintain the unit only with authorized or approved replacement parts.
- Keep all instructions permanently with the unit and all decals/labels/notices on the unit clean and visible.
- Do not override safety features.

Operator Protective Equipment

Personal protective equipment helps make tire servicing safer. However, equipment does not take the place of safe operating practices. Always wear durable work clothing during tire service activity. Loose fitting clothing should be avoided. Tight fitting leather gloves are recommended to protect operator's hands when handling worn tires and wheels. Sturdy leather work shoes with steel toes and oil resistant soles should be used by tire service personnel to help prevent injury in typical shop activities. Eye protection is essential during tire service activity. Safety glasses with side shields, goggles, or face shields are acceptable. Back belts provide support during lifting activities and are also helpful in providing operator protection. Consideration should also be given to the use of hearing protection if tire service activity is performed in an enclosed area, or if noise levels are high.

Definitions of Hazard Levels

Identify the hazard levels used in this manual with the following definitions and signal words:

DANGER

Watch for this symbol:



It Means: Immediate hazards, which will result in severe personal injury or death.

WARNING

Watch for this symbol:



It Means: Hazards or unsafe practices, which could result in severe personal injury or death.

CAUTION

Watch for this symbol:



It Means: Hazards or unsafe practices, which may result in minor personal injury or product or property damage.



Watch for this symbol! It means BE ALERT! Your safety, or the safety of others, is involved!

Safety Notices and Decals



Failure to follow danger, warning, and caution instructions may lead to serious personal injury or death to operator or bystander or damage to property. Do not operate this machine until you read and understand all the dangers, warnings and cautions in this manual. For additional copies of either, or further information, contact:

Hennessy Industries, Inc.

1601 J.P. Hennessy Drive
LaVergne, TN 37086-3565
(615) 641-7533 or (800) 688-6359
www.coatsgarage.com



Model
885

WARNING

RISK OF EXPLOSION
This equipment has internal arcing or sparking parts which should not be exposed to flammable vapors. Do not locate in a recessed area or below floor level.

THIS EQUIPMENT MUST BE EARTH-GROUNDED
The earth-ground connector built into the power cord provides protection to reduce the risk of electrical shock.



CAUTION

Do not use below garage floor or grade level.
Disconnect power before servicing this equipment.
To prevent electrical shock, do not remove cover. No user servicable parts inside. Refer servicing to qualified service personnel.

May Be Protected by one or more of the following patents:
USA - 4,423,632 - 4,499,768 - 4,939,941 - 5,311,777 - 5,337,256
AUSTRALIA - 564038

8113547 01

Standard Safety Devices

- Stop push button for stopping the wheel under emergency conditions.
- A hood guard of high impact plastic that is designed to prevent the counterweights from flying out in any direction except towards the floor.

★Balancing Your First Tire

1. Turn the machine OFF then ON (resets machine).

Note: The machine wakes up using standard clip-on wheel weight locations (c1 & c2) and wheel dimensions.

2. Mount a tire/wheel on the balancer that will use standard clip-on wheel weights.

Use the most appropriate mounting method.

3. Always remove any weights already attached to the wheel.

4. Enter A & D wheel dimensions using offset arm.

Automatic Measurement — pull offset arm out to the wheel, hold it still at clip-on weight position against wheel flange. Return arm to home position.



Offset Arm At Clip-On Weight Location

5. Enter Width wheel dimension.

Use plastic calipers to measure wheel width. Use keypad to enter Width value.

6. Lower the hood, press Start; wheel spins and unbalances are measured and displayed.

The corrective weight amount appears in the digital readout windows.

7. Raise hood after tire stops rotating.

Note: Wait for wheel to stop before raising the hood.

8. Rotate wheel to inboard (left plane) position of unbalance.

9. Attach inboard (left plane) corrective weight.

Attach specified weight amount at top-dead-center on inside flange of wheel.

10. Rotate wheel to outboard (right plane) position of unbalance.

11. Attach outboard (right plane) corrective weight.

Attach specified weight amount at top-dead-center on outside flange of wheel.

12. Lower the hood to respin the tire/wheel and check balance.

Your weight readings should now be 0.00.

Note: Throughout this manual tire dimensions are referred to as A, W, and D, see figure 2.

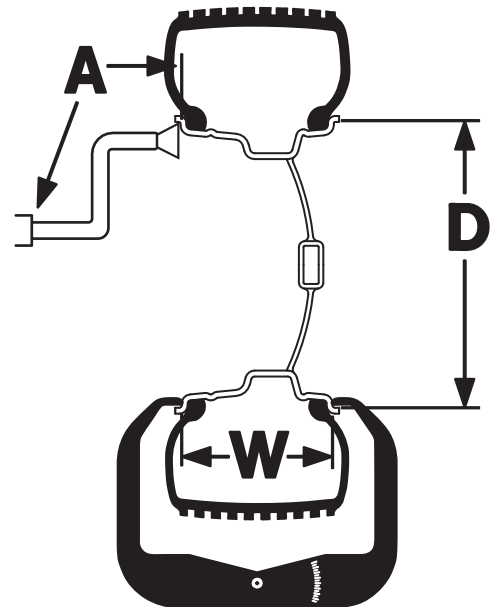

A, W, and D Tire Dimensions

Principle Operating Parts



Do It Now!

Now is a good time to fill out the Owner's Registry Card.



Know Your Unit

Compare this illustration with the unit before placing it into service. Maximum performance and safety will be obtained only when all persons using the unit are fully trained in its parts and operation. Each user should learn the function and location, of all controls.

Prevent accidents and injuries by ensuring the unit is properly installed, operated and maintained.

- A Control Panel or Video Display Panel**
- B Plug (back of machine)**
- C ON/OFF**
- D Weight Tray with Pockets for Corrective Weights**
- E Offset Arm, Measures A & D of Tire/Wheel (shown in home position)**
- F 40mm Shaft**
- G Hood Guard**
- H Accessory Pegs**

Note: Throughout this manual wheel weights are referred to as Clip-on or Tape-A-Weight™. Figure 3 shows an example of each weight.



Corrective Weight Examples: For Best Results, use BADA® Brand Wheel Weights.

Power Switch

The ON/OFF switch is located on the back of the balancer.

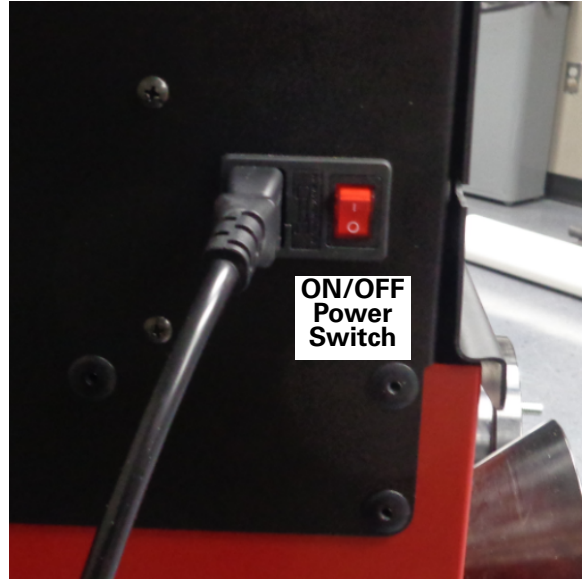

Operating the Balancer Mounting Wheel on Balancer Shaft



Avoid back injury, seek assistance when lifting heavy tire/rim assemblies onto the balancer shaft.



Failure to tighten the hub nut properly may result in the wheel dismounting, causing personal injury and property damage.

Select the most appropriate mounting method for the wheel you are balancing. Using the proper method ensures secure mounting and safe balancer operation, and prevents damage to the wheel.

On most wheels, the inner side of the wheel hub usually has the most uniform surface for wheel balancing. Always center the wheel by the most uniform shaped side of the hub to achieve the most accurate balance.

Regardless of mounting type, always make sure that the wheel is forced firmly against the shaft faceplate and that the hub nut engages the threaded shaft for at least four complete turns. To assist in centering the wheel properly, rotate the wheel and the shaft while tightening the hub nut.

Standard Back Cone/Collet Mounting

Most original equipment and steel wheels can be mounted properly using this method. The wheel is centered on a cone from the inner side of the hub.

1. Select the cone/collet that best fits the center hole in the wheel. Slide the cone/collet onto the shaft with the large end towards the cone spring.
2. Lift wheel onto the shaft and center it on the cone/collet.
3. Attach the pressure cup to the hub nut. Install the Hub nut assembly onto the shaft and tighten it securely against the wheel. The wheel must be forced firmly against the faceplate. The hub nut must engage the threads for at least four full turns.

Note: Use a nylon spacer (protective ring) to protect cus-tom wheel finishes.

Note: If the hub nut will not tighten completely, use the front cone mounting method.

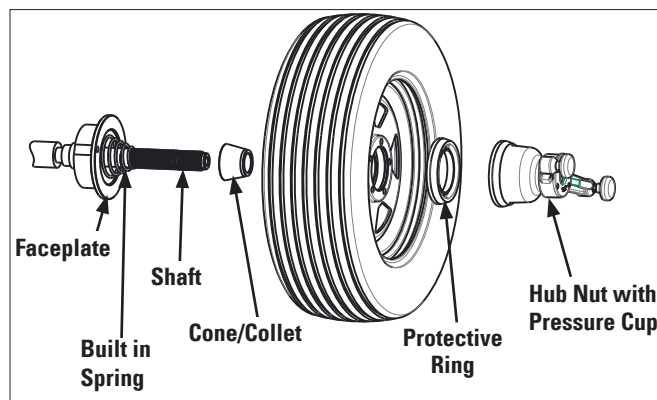

Standard Back Cone/Collet Mounting

Optional Front Cone/Collet Mounting

A wheel should be centered by the outer side of the hub only when the inner surface will not provide an accurate surface to center on.

1. Select the cone that best fits the center hole in the wheel.
2. Lift the wheel onto the shaft and slide it back against the shaft faceplate.
3. Slide the cone onto the shaft and into the center of the wheel. You will need to lift the tire to seat the cone in the center hole.
4. Install the hub nut (without pressure cup) onto the shaft. Tighten it securely against the cone. The hub nut must engage the threads for at least four full turns.

Note: If the hub nut will not tighten completely because of a lack of threads, use an additional cone as a spacer between the mounting cone and the hub nut. The wheel must be forced firmly against the faceplate.

Note: Do not front cone chrome or clad wheels.

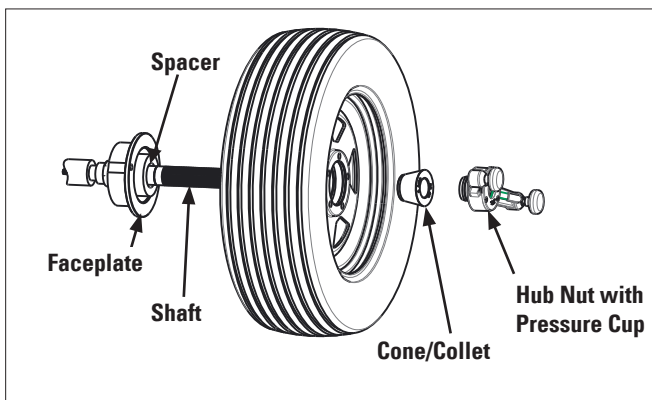

Front Cone/Collet Mounting

Alternate Mounting

If the wheel has a protruding outer hub which will not permit the use of the pressure cup, or the cup will not permit the hub nut to engage at least four turns of the shaft, this alternate method should be used.

1. Place the cone spring onto the balancer shaft with the large end towards the faceplate.
2. Select the cone/collet that best fits the center hole in the wheel. Slide the cone/collet onto the shaft with the large end towards the faceplate.
3. Lift wheel onto the shaft and center it on the cone/collet.
4. Use the small nylon spacer (no-mar ring) or a centering cone/collet to press against the outer wheel hub.
5. Install the hub nut (without the pressure cup) onto the shaft. Tighten securely.

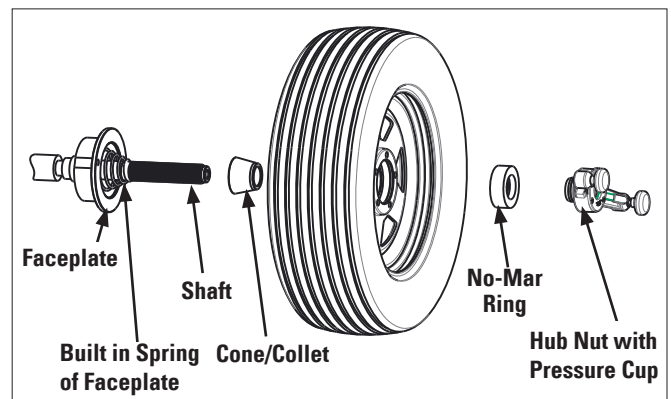

Alternate Mounting

Control Panel And Display

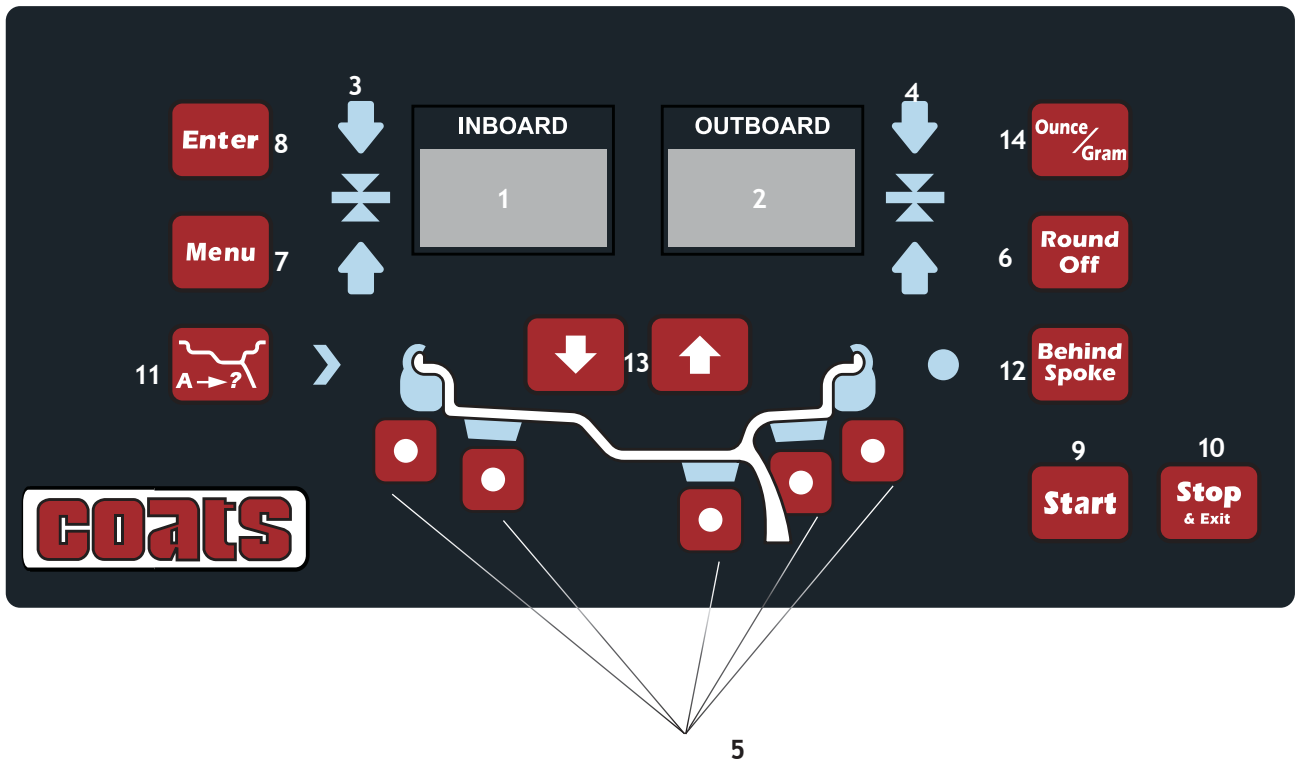

- 1-2 Digital readouts, AMOUNT OF UNBALANCE, inside/outside/static
Push button, unbalance reading below the threshold
- 3-4 Digital readouts, POSITION OF UNBALANCE, inside/outside/static
- 5 Push button, selection of correction mode
- 6 Push button, unbalance reading
- 7 Push button, FUNCTIONS MENU
- 8 Push button, menu selection confirmation
- 9 Push button, cycle start
- 10 Push button, emergency/home
- 11 Push button, position repeater
- 12 Push button, SPLIT (hidden weight)
- 13 Minimum Maximum & Menu Button
- 14 Push button, g/oz measuring unit selection

*Default is OFF, see pg16 to turn ON this feature

Note: Only press buttons with your fingers. Never use the weight hammer or other pointed objects to press buttons.

Operation Functions Menu

Use of the Wheel Balancer

STANDARD BALANCING (clip-on counterweights)

Wheel dimensions setting

1. Using the special grip, move the end of gauge against the rim as shown in the figure:

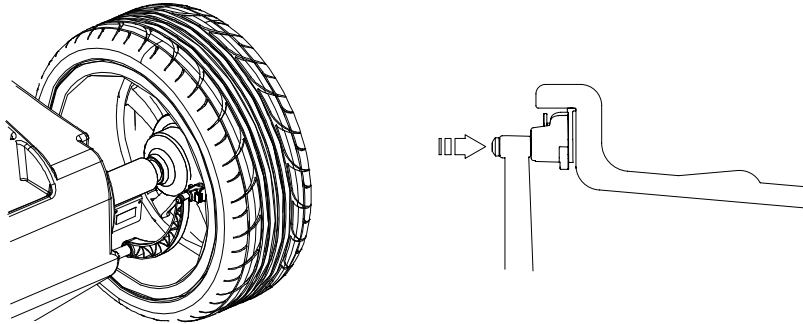

2. While the gauge is moving the following appears:

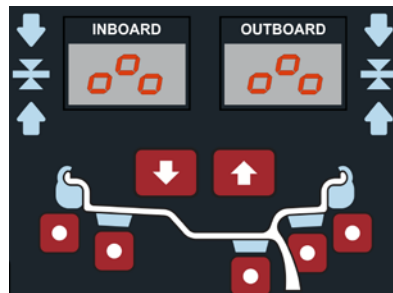

3. Hold the gauge in position for at least 2 seconds.

If the acoustic signal is enabled (by a “beep”) Measurement stored:

 **MENU - ACOUSTIC SIGNAL**), the acquisition of the dimensions is accompanied

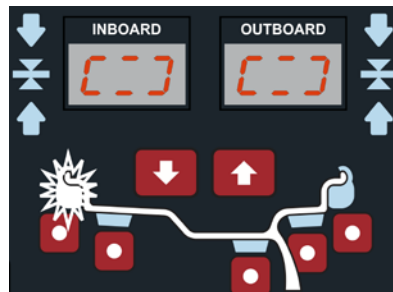

4. Set the distance and diameter gauge to the home position.

The balancing machine automatically interprets the presence of a rim with clip-on weight correction:

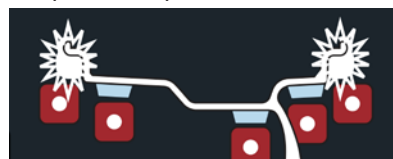

Page left intentionally blank.

Result of the measurement and weight application

If the unbalance is out of tolerance:

- When the spin is complete, bring the unbalance into correction position by turning the wheel by hand. The spindle is automatically locked in correction position (if not disabled the wheel lock and for rotation speeds less than 20 rpm).
If the acoustic signal is enabled (🔊 MENU - ACOUSTIC SIGNAL), a beep will sound when the correction position has been reached.

- The symbol  is shown on the Display (Item 3+4 on Pg 6) on the side corresponding to the active correction plane.

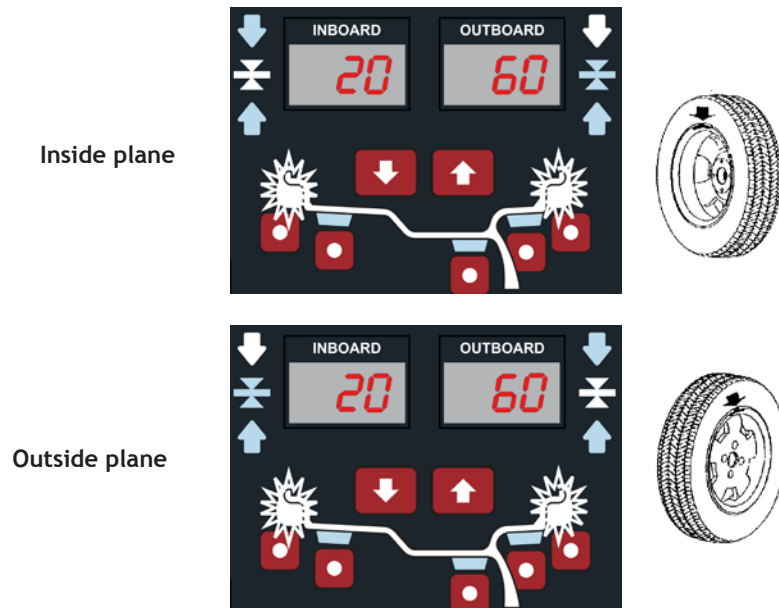

- Manually apply the number of weights shown on the display on the rim at 12 o'clock using clip-on weights:



IF THE OUT-OF-BALANCE IS LESS THAN THE CHOSEN THRESHOLD VALUE, "📄" APPEARS INSTEAD OF THE OUT-OF-BALANCE VALUE TO INDICATE, ON THAT PARTICULAR SIDE, THAT THE WHEEL IS IN TOLERANCE.

IF AUTOADAPTIVE IS DISABLED, PRESS Round Off Button CORRESPONDENCE TO THE UNBALANCE INDICATORS TO VIEW THE RESIDUAL UNBALANCE BELOW THE CHOSEN TOLERANCE THRESHOLD.

- After applying the weights, spin the wheel to check the correction made, checking that both planes are within tolerance.

BALANCING WITH ADHESIVE WEIGHTS (ALU)

Wheel dimensions setting

Using the dedicated grip, move the gauge tip up against the inside of the rim and make two consecutive measurements starting from the inside (FI) as shown in the figure. The two preselected positions coincide with the point where the counterweight is to be applied.

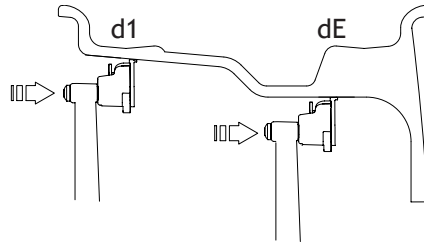

If the acoustic signal is enabled (👉 MENU - ACOUSTIC SIGNAL), the acquisition of the dimensions is accompanied by a “beep”.

Set the gauge to the home position.

The balancer automatically interprets the presence of a rim with adhesive weight correction:

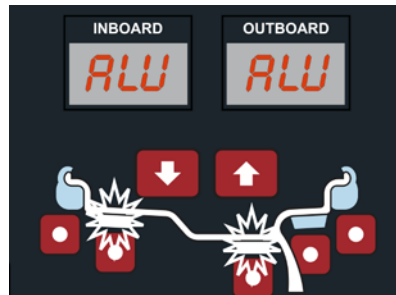

If the wheel dimensions have been entered incorrectly, the parameters can be modified without repeating the balancing spin:

1. Press:

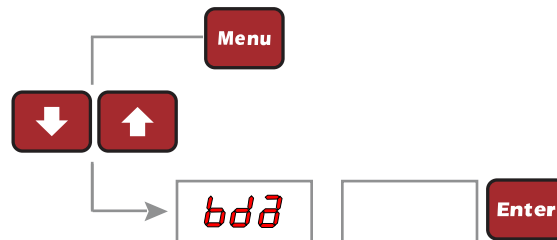

2. Set the value of the dimensions in sequence:

dI=inside weight distance
dE=outside weight distance
aI=inside weight distance
aE=outside weight distance

using the buttons  .

3. Press the button  to confirm the setting and go to the next dimension.

Press the button  at any time to interrupt dimension setting and return to the main screen.

Result of the measurement and weight application

If the unbalance is out of tolerance:

1. When the spin is complete, bring the unbalance into correction position by turning the wheel by hand.
The spindle is automatically locked in correction position (if not disabled the wheel lock and for rotation speeds less than 20 rpm)
If the acoustic signal is enabled ( **MENU - ACOUSTIC SIGNAL**), a beep will sound when the correction position has been reached.

2. The symbol  is shown on the Display (Item 3+4 on Pg 6) on the side corresponding to the active correction plane.

3. Manually apply on the rim, at 12 o'clock, the amount of weight shown on the display, by using adhesive weights:

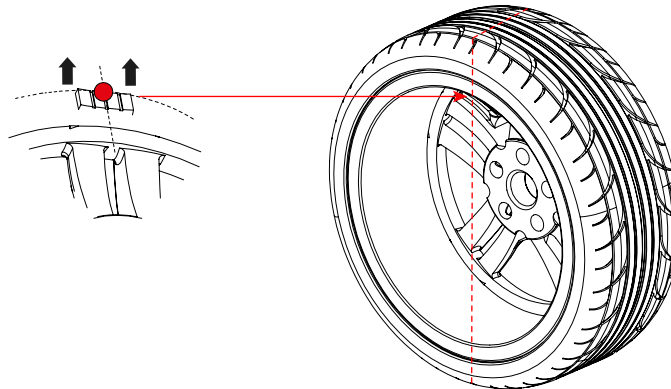

IF THE OUT-OF-BALANCE IS LESS THAN THE CHOSEN THRESHOLD VALUE, "  " APPEARS INSTEAD OF THE OUT-OF-BALANCE VALUE TO INDICATE, ON THAT PARTICULAR SIDE, THAT THE WHEEL IS IN TOLERANCE.



IF AUTOADAPTIVE IS DISABLED, PRESS **Round Off Button** CORRESPONDENCE TO THE UNBALANCE INDICATORS TO VIEW THE RESIDUAL UNBALANCE BELOW THE CHOSEN TOLERANCE THRESHOLD.

4. After applying the weights, spin the wheel to check the correction made checking that both planes are within tolerance.

BALANCING WITH A MIX OF ADHESIVE AND CLIP-ON WEIGHTS AND STATIC BALANCING

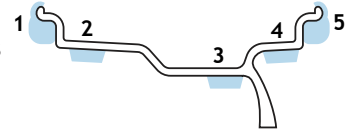
After dimension acquisition in standard balancing mode, pressing the buttons



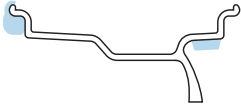
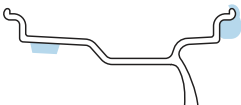
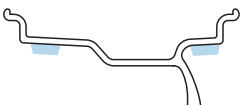
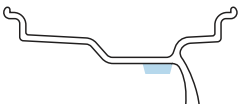

 WEIGHT APPLICATION POSITION		
Correction type	Inside	Outside
	Clip-on weight at 12 o'clock	Clip-on weight at 12 o'clock
	Clip-on weight at 12 o'clock	Adhesive weight at 12 o'clock
	Adhesive weight at 12 o'clock	Clip-on weight at 12 o'clock
	Adhesive weight at 12 o'clock	Adhesive weight at 12 o'clock
STATIC 	Adhesive weight at 12 o'clock	

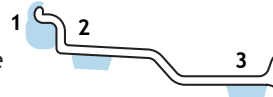
After dimension acquisition in ALU mode, pressing the

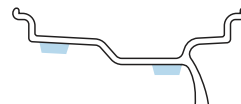

following correction modes. The adhesive weight application distance and diameter are measured by means of the automatic gauge, except for the static unbalance where the dimensions acquired are modified following some fixed parameters.

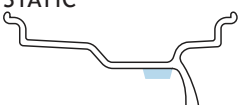
 WEIGHT APPLICATION POSITION		
Correction type	Inside	Outside
	Adhesive weight at 12 o'clock	Adhesive weight at 12 o'clock
	Clip-on weight at 12 o'clock	Adhesive weight at 12 o'clock
STATIC 	Adhesive weight at 12 o'clock	

STATIC UNBALANCE

The static unbalance is shown on display (1) and the relative correction position on the LED display.

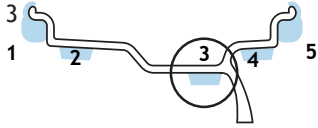



Note: Must press the button to show Static.

The correction weight application diameter cannot be set, but is deduced from the dimensions acquired in standard or ALU mode through interpolation algorithms and the use of fixed parameters. Tolerance control is the same as for standard balancing, only that it refers to a single correction plane.

EXACT POSITIONING OF THE ADHESIVE WEIGHT BY MEANS OF THE GAUGE WITH CLIPS

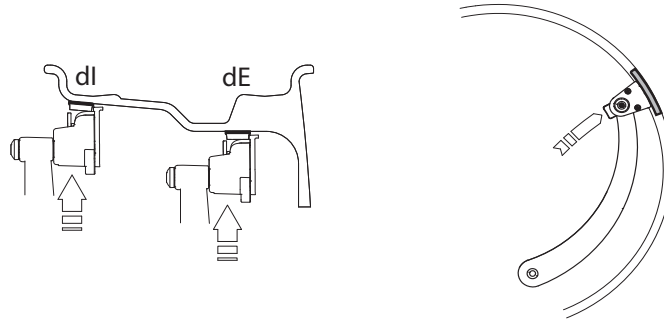
- Press  if using the correction method with adhesive weights on the inside of the rim.



- Fit the correction weight in the specific gauge seat with the adhesive part facing upwards.
- Bring the wheel into correct angular position for the plane to be corrected.
- If the wheel clamp option is enabled ( MENU') the wheel is automatically clamped in the correction position.
- Pull out the gauge until the leds (Item 5 on Pg 6) light up next to the correction weight.
If the buzzer is enabled ( MENU), the attainment of the weight application distance is accompanied by a beep.

- INSIDE CORRECTION POSITION

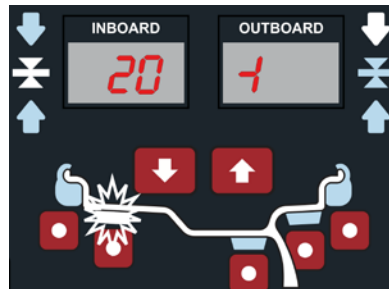

- OUTSIDE CORRECTION POSITION

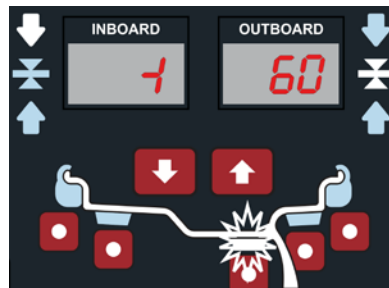





- Rotate the gauge until the correction weight adheres to the rim.
- The fact that the weight application position is no longer vertical is automatically compensated.

To cancel the function, press the  button again.

HIDE THE ADHESIVE WEIGHTS (Behind Spoke)

Behind Spoke is only possible in the event of static unbalance or **ALU** external side and is used to hide any adhesive weights correcting unbalance behind the rim spokes.

1. Perform an unbalance measurement spin.
2. Position the static unbalance or outside ALU in the correction position .
3. Bring one of the spoke at 12 o'clock and press .
4. Turn the wheel in the unbalance rotation direction indicated on the display until the second spoke is at 12 o'clock and press the  button.
5. Now, turn the wheel to the correction positions indicated by the LEDs and correct the value displayed. The Autolock function should lock 2 the two locations for correct weights. To return to the normal unbalance indication, press  button.

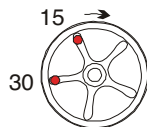

Set the first split unbalance to correction position 1



See pg 22
for errors 24, 25 & 26

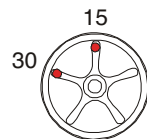

Correction position 1

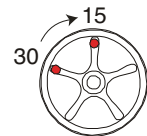

Set the second split unbalance to correction position 2

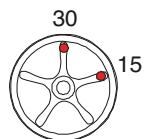

Correction position 2



AUTOMATIC MINIMIZATION OF STATIC UNBALANCE

This program is designed to improve the quality of balancing without any mental effort or loss of time by the operator. In fact by using the normal commercially available weights, with pitch of 5 in every 5 g, and by applying the two counterweights, which a conventional wheel balancer rounds to the nearest value, there could be a residual static unbalance of up to 4 g. The damage of such approximation is emphasized by the fact that static unbalance is cause of most of disturbances on the vehicle. This new function, resident in the machine, automatically indicates the optimum entity of the weights to be applied by approximating them in an "intelligent" way according to their position in order to minimize residual static unbalance.

Unbalance Match Mount Balance

The program allows total wheel out-of-balance to be reduced by compensating, when possible, tire and rim out-of-balance values. It is suitable for static unbalance values in excess of 30 grams. It requires two runs, rotating the tire on the rim on the second run.

1. Press:



If no unbalance was measured before, START appears on the display. Press this button to proceed.



Close the guard (and press the button **Start** if start from the guard is disabled, **MENU**) to perform a spin.

2. Make a reference mark on the flange and the rim (using a piece of chalk, for example). With the aid of a tire remover, turn the tire on the rim by 180°. Refit the wheel in such a way that the reference marks on the rim and the flange coincide.



Close the guard (and press the button **Start** if start from the guard is disabled, **MENU**) to perform a spin.

3. RH display: percentage reduction value
LH display: actual static unbalance value which can be reduced by rotation



4. Mark the two positions of the rim and tire, and turn the tire on the rim until the positions coincide to achieve the optimization shown on the display.

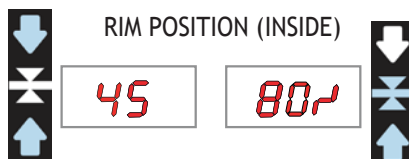
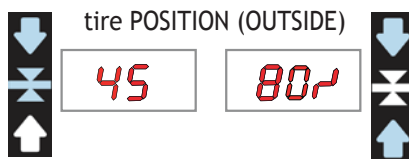

When optimization is complete, perform a new spin or press **Stop & Exit** to return to the measurement screen.

Setup

MENU ACCESS DIAGRAM

This is used to personalize some balancer functions and to perform calibrations.

To access this section, press the **Menu** button.

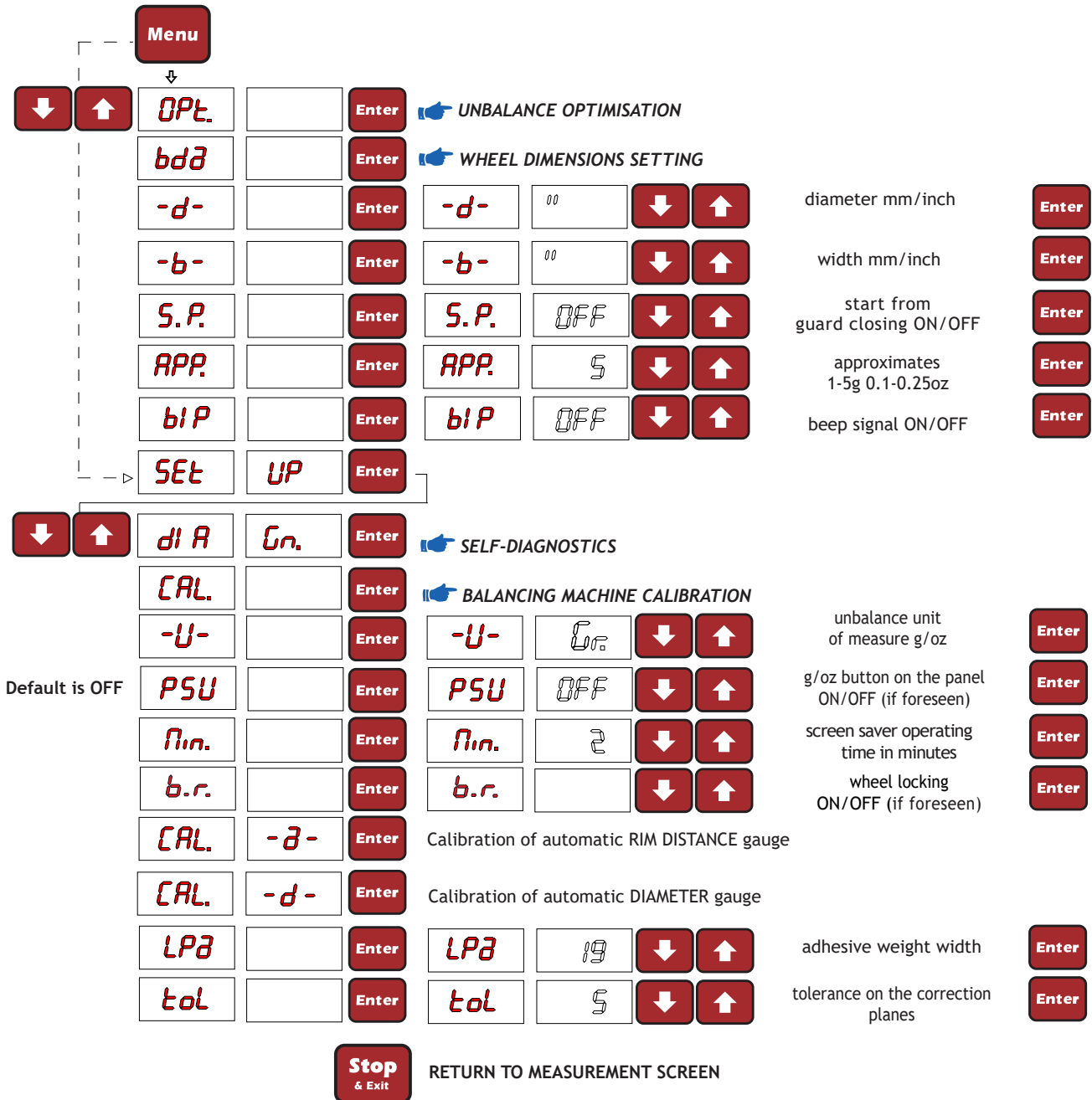

Note: After leaving the Set Up Menu Functions, you will need to lower the hood 2x to start your next balance check.

SELF-DIAGNOSTICS

The machine can perform self-diagnostics to check the LED's on the control panel and make sure the encoder reads correctly.

To perform this operation, view the SETUP menu.

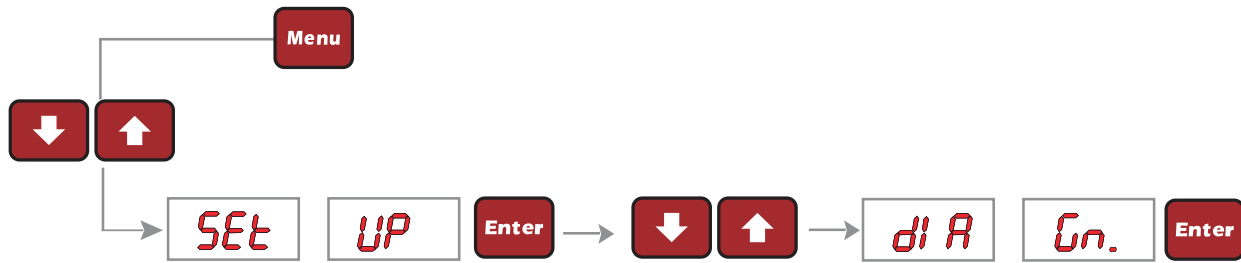

In the self-diagnostics sequence, all the LED's on the panel light up for a few seconds in order to check operation. When the LED's go out, the machine automatically moves on to the encoder reading phase. When the wheel is turned manually (forwards and backwards), the display shows its exact position. The value lies between 0 (zero) and 255. (*Consult the maintenance manual or contact Technical Service*).

BALANCING MACHINE CALIBRATION (Calibrate in OZ mode)

To calibrate the balancing machine, use a wheel with steel rim of average dimensions, (e.g. 16").

To properly perform the procedure:

- Mount a wheel on the machine, even unbalanced, and very carefully set its dimensions.



SETTING INCORRECT MEASUREMENTS WILL RESULT IN THE MACHINE NOT BEING CORRECTLY CALIBRATED, AND BALANCING OF SUBSEQUENT WHEELS WILL HENCE BE INCORRECT UNTIL THE MACHINE IS RECALIBRATED WITH THE CORRECT MEASUREMENTS!!

IF ERR. 241 OCCURS, MANUALLY SET THE WIDTH VALUE BEFORE ACCESSING THE WHEEL BALANCER AUTOCALIBRATION FUNCTION.

1. Display the CALIBRATION function from the SETUP menu

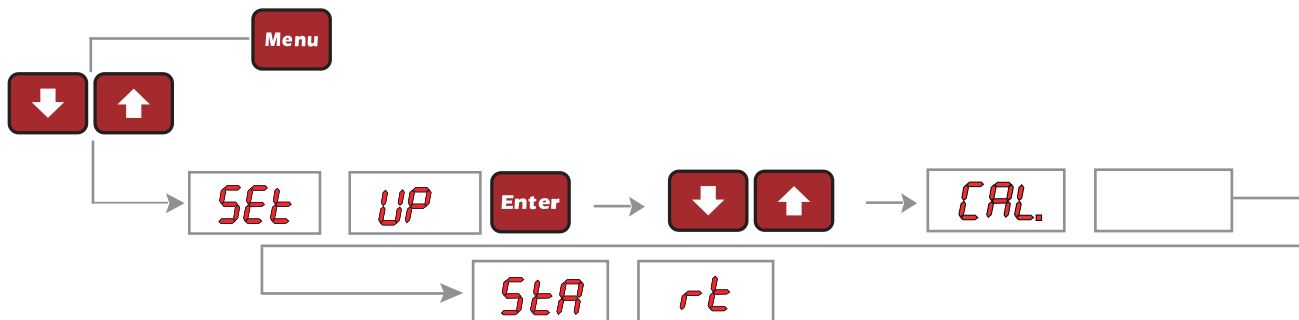

Close the guard and press the **Start** button to perform a spin.

2. Add a standard weight of 4.00 oz anywhere on the outer side plane.



Close the guard and press the **Start** button to perform a spin.

- Shift the standard weight from the outside to the inside keeping the same position.

4.00 Add.

Close the guard and press the **Start** button to perform a spin.

- Turn the wheel until the Cal weight is at the top (12 o'clock) and press **Enter**.

r 0 7 []

- Pull A&D Arm to the Rim Flange, rotate wheel to center Cal weight to the A&D weight clip and press

Enter

r - 0 []

Pressing the button **Stop & Exit** a default value is set.

CALIBRATION COMPLETE

CAL []

To cancel calibration at any time, press **Stop & Exit**.

AUTOMATIC GAUGES CALIBRATION

Distance gauge calibration

- Display the distance gauge CALIBRATION function from the SETUP menu

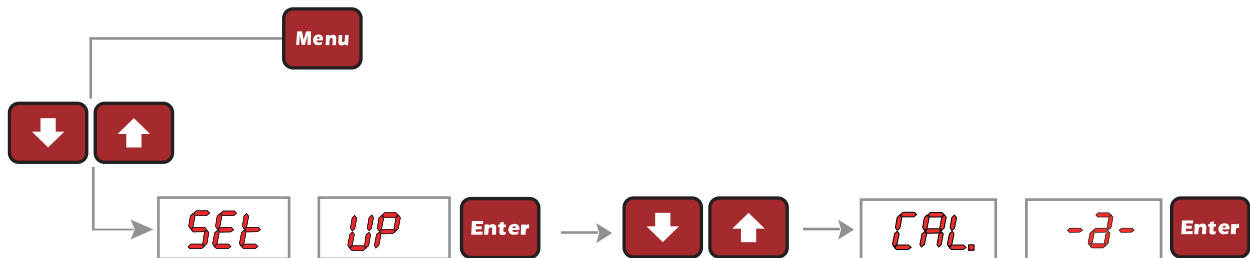

- Leave the distance gauge in home (rest) position and press **Enter**.

r P []

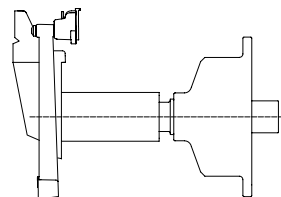

3. Move the distance gauge pusher in line with the Face Plate and press **Enter**.

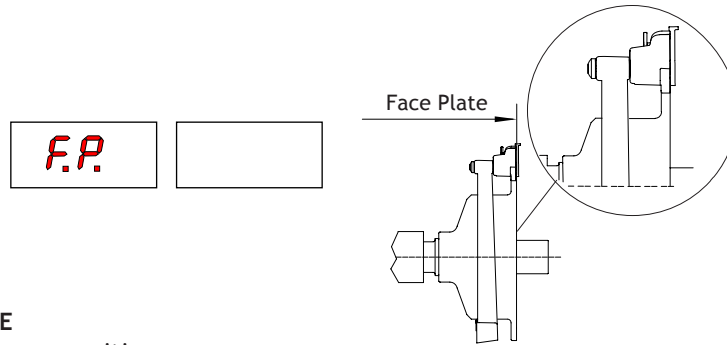

CALIBRATION COMPLETE

- Return the gauge to home position.
- The wheel balancer is ready for operation.



IN THE EVENT OF ERRORS OR FAULTY OPERATION, THE WRITING "R.P.": APPEARS ON THE DISPLAY : SHIFT THE GAUGE TO THE Home POSITION AND REPEAT THE CALIBRATION OPERATION EXACTLY AS DESCRIBED ABOVE. IF THE ERROR PERSISTS, CONTACT THE TECHNICAL

SERVICE DEPARTMENT. IN THE EVENT OF INCORRECT INPUT IN THE RIM DISTANCE GAUGE CALIBRATION FUNCTION, PRESS **Stop & Exit** TO CANCEL IT.

Diameter gauge calibration

1. Display the diameter gauge CALIBRATION function from the SETUP menu

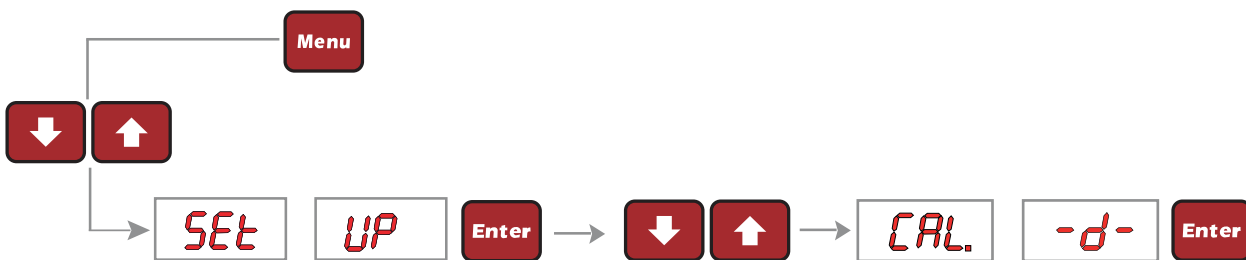

2. Place the gauge rod on the spindle shell as shown in the figure and press **Enter**.

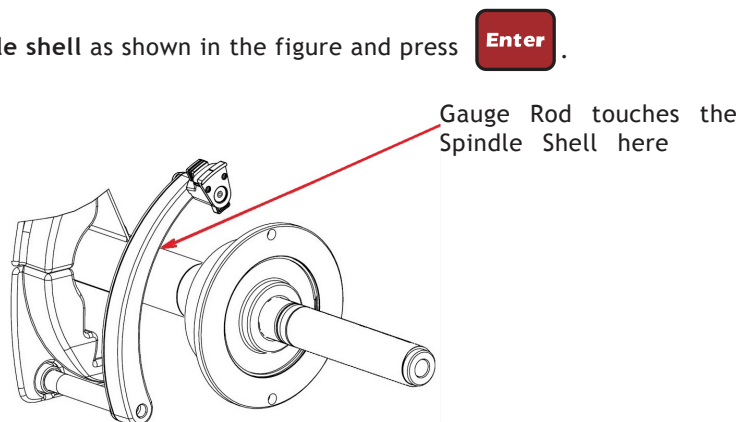

3. Turn the gauge downward positioning the gauge rod in contact with the spindle sleeve (P.2, Position 2)

as shown in the figure and press **Enter**

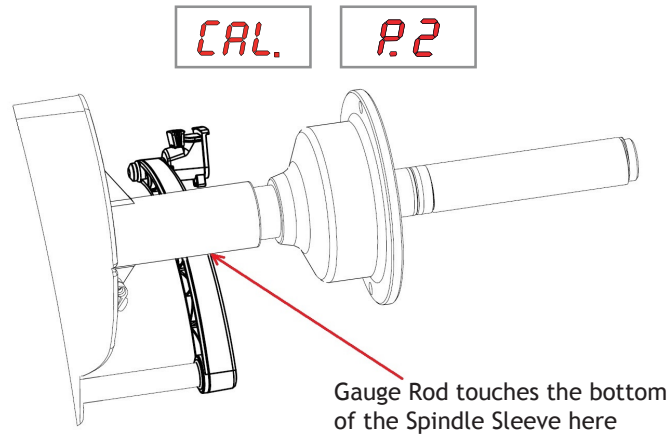

CALIBRATION COMPLETE

- Return the gauge to home position.
- The wheel balancer is ready for operation.



IN CASE OF ERRORS OR MALFUNCTIONS, THE INDICATION OF THE SAME STEP [P.1] OR [P2], ALWAYS REAPPEARS ON THE DISPLAY. MOVE THE GAUGE BACK INTO HOME POSITION AND REPEAT THE CALIBRATION OPERATION AS DESCRIBED ABOVE; IF THE ERROR PERSISTS, CONTACT TECHNICAL SERVICE.

*IF ERRONEOUSLY ACCESSING THE DIAMETER GAUGE CALIBRATION FUNCTION, PRESS **Stop & Exit** TO CANCEL IT.*

ADHESIVE WEIGHT WIDTH

Indicates the average width of the adhesive weights on the market.

Change **ONLY** if the width of the adhesive weights used for unbalance correction differ +/- 3 mm with respect to that shown on the display (default=19mm).

Diagnostics

INCONSISTENT UNBALANCE READINGS

In some cases, when a wheel that has just been balanced is repositioned on the balancer, the machine can detect an unbalance.

This is not a machine problem but is due to faulty mounting of the wheel on the flange. In other words, when mounting the wheel after initial balancing, it has taken another position with respect to the balancer shaft axis.

If the wheel has been mounted on the flange with screws, the screws may not have been tightened correctly (criss-cross sequence) or the tolerances of the holes drilled in the wheel may be too large. Small errors, up to 10 grams (0.4 oz), are to be considered normal in wheels locked with the relative cone: The error is normally greater for wheels locked with screws or studs.

Following balancing, if the wheel is still unbalanced when installed on the vehicle, this could be due to an unbalanced brake drum or the tolerances of the holes drilled in the rim and drum are too large.

ALARM SIGNAL

The machine has a self-diagnostics cycle which identifies the most frequent malfunctions during the normal work cycle. These malfunctions are processed by the system and shown on the display.



THE INFORMATION IN THE POSSIBLE REMEDY COLUMN REQUIRES WORK TO BE PERFORMED BY SPECIALIST TECHNICIANS OR OTHER AUTHORISED PEOPLE WHO MUST ALWAYS WORK USING THE PERSONAL PROTECTIVE EQUIPMENT INDICATED IN THE INSTALLATION MANUAL. IN SOME CASES, THIS WORK CAN BE PERFORMED BY A NORMAL OPERATOR.

ERROR	PROBLEM	POSSIBLE SOLUTIONS
Black	The wheel balancer does not switch on	<ul style="list-style-type: none">Verify correct connection to the mainsVerify and eventually replace the fuses on the power cardVerify monitor functionReplace the computer board
Err. 1	No rotation signal	<ul style="list-style-type: none">Check in self-diagnostics that the encoder functions properlyReplace the phase pick-up boardReplace the computer board
Err. 2	Speed too low during detection During the unbalance measurement revolutions, the wheel speed has fallen to below 42 rpm	<ul style="list-style-type: none">Make sure that a vehicle wheel is mounted on the wheel balancerUse the self-diagnostics function to check the encoderDisconnect the piezo connectors from the board and do a spin (if no error is detected, replace the piezo sensors)Replace the CPU board
Err. 3	Unbalance too high	<ul style="list-style-type: none">Verify wheel dimension settingsCheck detection unit connectionsPerform machine calibrationMount a wheel with more or less known unbalance (less than 100 grammes) and verify the response of the machineReplace the computer board
Err. 4	Rotation in opposite direction After pressing [START], the wheel starts turning in the opposite direction (anticlockwise)	<ul style="list-style-type: none">Check in self-diagnostics that the encoder functions properlyCheck the bearing/spring of the phase generator
Err. 5	Guard open	<ul style="list-style-type: none">Reset the errorClose the guardVerify the function of the protection Switch
Err. 7/ Err. 8/ Err. 9	NOVRAM parameter read error	<ul style="list-style-type: none">Switch off the machine and wait for at least ~ 1 min.; re-start the machine and check it works properlyRepeat machine calibrationReplace the computer board

Err. 11	Speed too high error During unbalance measurement rotation, wheel speed is more than 270 rpm	<ul style="list-style-type: none"> ▪ Check in self-diagnostics that the encoder functions properly ▪ Replace the computer board
Err.14 / Err.15 / Err.16 / Err.17 / Err.18 / Err.19	Unbalance measurement error	<ul style="list-style-type: none"> ▪ Check in self-diagnostics that the encoder functions properly ▪ Check detection unit connections ▪ Verify machine earth/ground connection ▪ Mount a wheel with more or less known unbalance (less than 100 g) and verify the response of the machine ▪ Replace the computer board
Err. 20	Wheel still. The wheel must remain still for more than one second after START	<ul style="list-style-type: none"> ▪ Use the self-diagnostics function to check the encoder ▪ Check the connections on the power board ▪ Replace the computer board
Err. 21	Motor on for more than 15 seconds	<ul style="list-style-type: none"> ▪ Use the self-diagnostics function to check the encoder ▪ Check the connections on the power board ▪ Replace the computer board
Err. 24	Distance between the spokes less than 18 degrees	<ul style="list-style-type: none"> ▪ The minimum distance between the spokes where the unbalance is to be split must be greater than 18 degrees ▪ Repeat the SPLIT function increasing the distance between the spokes
Err. 25	Distance between the spokes greater than 120 degrees	<ul style="list-style-type: none"> ▪ The maximum distance between the spokes where the unbalance is to be split must be less than 120 degrees ▪ Repeat the split function increasing the distance between the spokes
Err. 26	First spoke too far from the unbalance	<ul style="list-style-type: none"> ▪ The maximum distance between the unbalance position and the spoke must be less than 120 degrees ▪ Repeat the split function increasing the distance between the spokes and the unbalance
Err.230÷238	Operating touch monitor errors	<ul style="list-style-type: none"> ▪ Restart the balancing machine ▪ Calibrate the touch monitor ▪ Check touch monitor connections ▪ Replace the touch monitor
Err. 240	Machine setting error	<ul style="list-style-type: none"> ▪ Execute the initialization function
Unbalance incorrect with back centring cones	Mount the wheel in vertical position and push the sleeve up against the wheel. If necessary, repeat locking/unlocking/locking and perform the procedure again	<ul style="list-style-type: none"> ▪ Mount the wheel in vertical position and push the sleeve up against the wheel. If necessary, repeat locking/unlocking/locking and perform the procedure again.

Installation Instructions

A factory trained COATS® Service Technician must perform the install, setup, and initial test procedures on your wheel balancer. Do not attempt to install and setup the unit yourself. Accurate and reliable operation of your unit depends on proper installation. Please contact COATS® directly at 1-800-688-9240 for the Certified Service Partner nearest you.

Receiving

The shipment should be thoroughly inspected as soon as it is received. The signed bill of lading is acknowledgement, for the carrier, of receipt in good condition of the shipment covered by our invoice.

If any of the goods called for on this bill of lading are shorted or damaged, do not accept them until the carrier makes a notation of the shorted or damaged goods on the freight bill. Do this for your own protection.

NOTIFY THE CARRIER AT ONCE if any hidden loss or damage is discovered after receipt and request him to make an inspection. If the carrier will not do so, prepare an affidavit to the effect that you have so notified the carrier (on a certain date) and that he has failed to comply with your request.

IT IS DIFFICULT TO COLLECT FOR LOSS OR DAMAGE AFTER YOU HAVE GIVEN THE CARRIER A CLEAR RECEIPT.

File your claim with the carrier promptly. Support your claim with copies of the bill of lading, freight bill, invoice, and photographs, if possible.

Although COATS responsibility ceases upon delivery of the shipment to the carrier, we will gladly assist in tracing lost shipments. Our willingness to assist in every possible manner does not make COATS responsible for collection of claims, or replacement of lost or damaged materials.

Standard Accessories

- Built-in Weight Tray
- 3 Back Cones (A, B, C)
- Truck Cone (D)
- Hub Nut
- Pressure Cup
- Rim Width Calipers

Features

- Balances Most Automotive Wheels
- Single-Spin Dynamic Two-Plane or Static Balancing
- Vertical Wheel Mounting
- Back Cone and Front Cone Mounting
- “No Bolt-Down” Installation
- Scratch Resistant Control Panel
- Easy-To-Read LEDs and Displays
- Automatic Calibration
- Removable Shaft Stud
- Automatic Rim Gauge Return
- Dynamic, Static, and Alloy Operating Modes

Specifications

- Weight (excluding adapter) 130 lbs.
- Single-phase power supply 115V, 50/60 Hz, 3A
- Protection class IP 54
- Max power consumption 0.8 Kw
- Balancing speed < 130 rpm
- Cycle time for average wheel (14 kg) 6-8 seconds
- Max.resolution of measurement 0.10 oz
- Position resolution $\pm 1.4^\circ$
- Average noise < 70dB (A)
- Rim-machine distance 0 - 252 mm
- Rim width setting range 1.5 to 20 inches
- Diameter setting range 10 to 30 inches

Electrical Requirements

See serial tag for the appropriate power requirements of your machine.

Always have a qualified electrician install the proper receptacles in accordance with state and local codes.

Floor and Space Requirements

The balancer must be located on a flat floor of solid construction, preferably concrete. The balancer must sit solidly on its three feet. If the balancer is not level, does not sit solidly on its three feet, or is placed on an unstable floor, the balancer will not function properly and may produce inaccurate balance readings.

Do not operate the balancer while it is on the pallet.

Select a location for the balancer that provides a level, solid floor, and adequate clearance around and above the balancer. Make sure the location selected has enough room above and behind the unit so the hood can be raised completely. The location must also provide working room for mounting and removing wheels. Make sure the area has adequate lighting

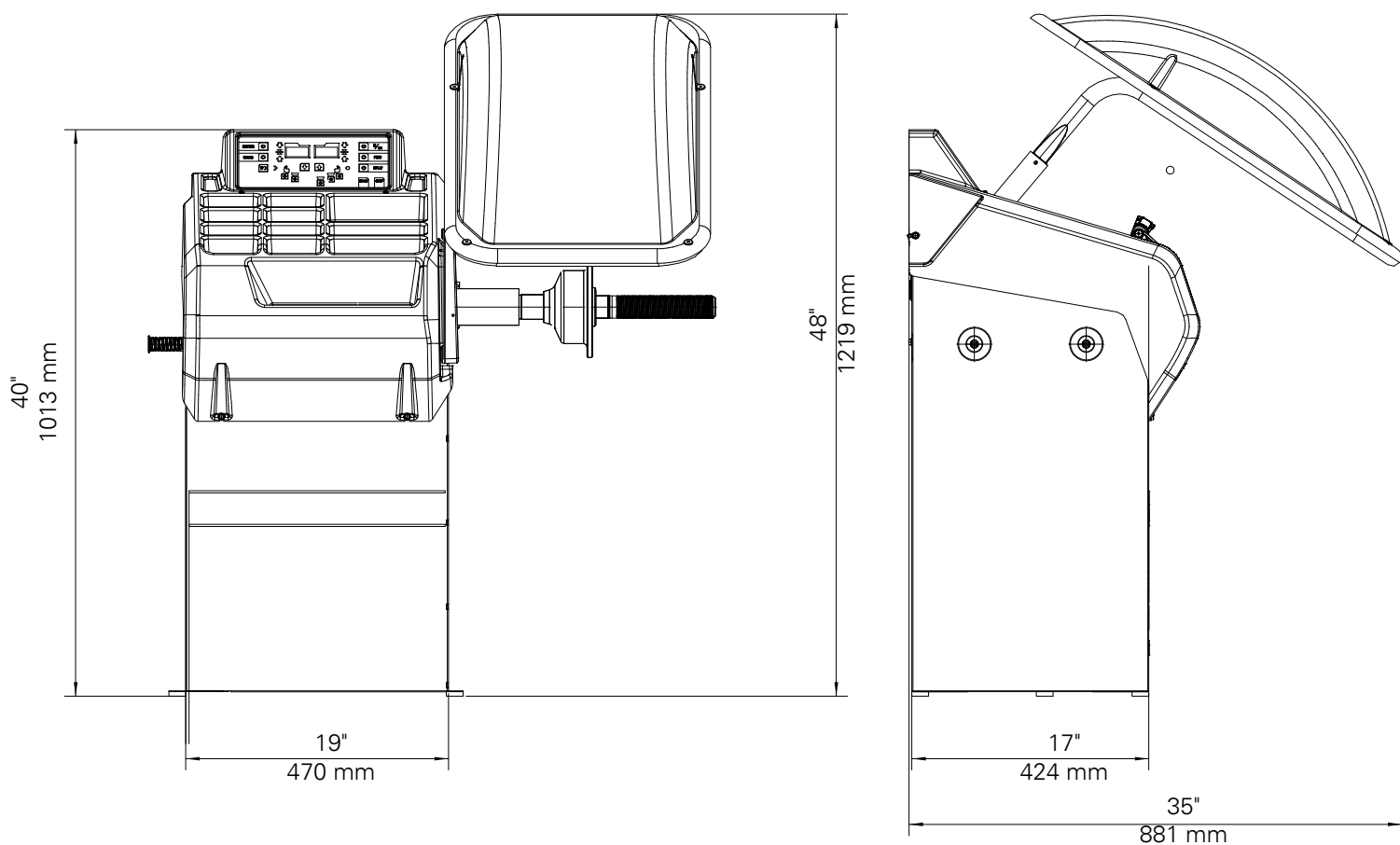

Space Requirements

Unpacking the Unit

1. Remove the shipping carton from the pallet. **Fig. 1**
2. Remove all loose parts and accessories packed around the unit.

Remove Balancer from Pallet

3. Remove the shipping bolts that hold the balancer to the pallet.



Do not use the control panel, control panel base, accessory storage, faceplate, hood or shaft to lift the balancer.



Use help to remove the balancer from the pallet. The unit is heavy and the weight is not evenly distributed. Dropping the unit may cause personal injury or equipment damage.

4. Lift the balancer off the pallet and place it in its operating location.

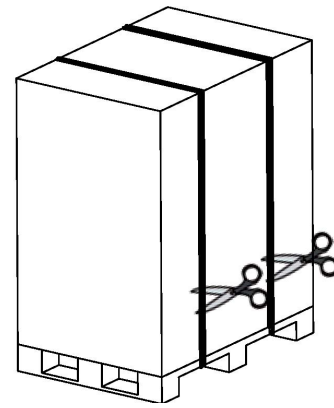

Fig. 1

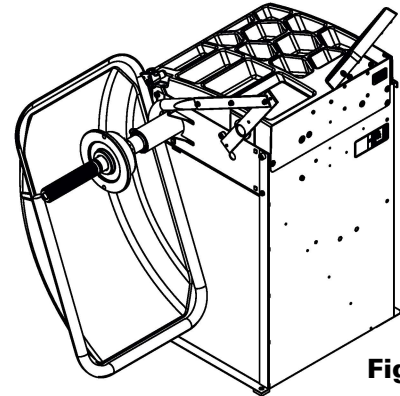

Fig. 2

Hood Installation

5. Remove one screw holding the Hood bracket to the balancer arm. **Fig. 2**
6. Align the Hood bracket with the balancer arm and secure with three screws. **Fig. 3 & 4**

Connect to Power

Your factory trained COATS® Service Technician should do the final check to verify the power installation before connecting the balancer to a power supply. Failure due to improper power connection may void the warranty.

Initial Testing

1. Plug the unit into an appropriate power outlet. If the circuit breaker for the outlet is off, turn it on.
2. Turn the balancer on. The power switch is on the back of the unit.
3. Test the hood switch with the auto spin feature to ensure proper installation. If problems check the height of the hood switch button for proper operation.

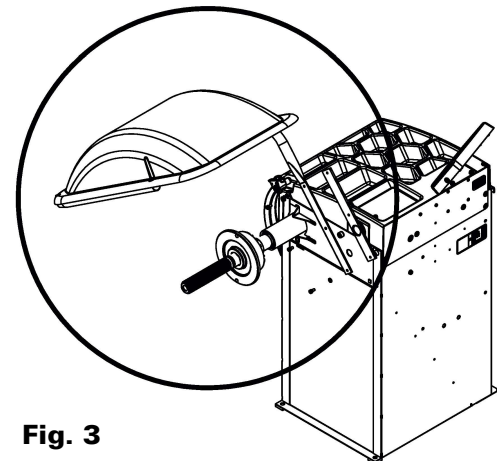

Fig. 3

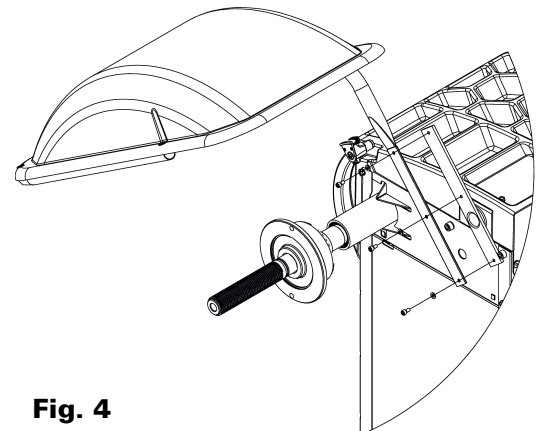

Fig. 4

NOTES