

COATS®

885 Wheel Balancer



Parts Identification

READ these instructions before placing unit in service. KEEP these and other materials delivered with the unit in a binder near the machine for ease of reference by supervisors and operators.

HENNESSY
INDUSTRIES

1601 J. P. Hennessy Drive, La Vergne, TN USA 37086 615/641-7533 800/688-6359 www.coatsgarage.com
HENNESSY INDUSTRIES LLC Manufacturer of COATS®, AMMCO® and BADA® Automotive Service Equipment and Tools.

Manual Part No.: 85611591 02
Revision: 02/20

Parts Identification

The following pages include parts breakdowns with exploded view illustrations to help with ordering replacement or spare kits. Assemblies are noted where it is recommended that individual parts not be ordered separately. Note that the parts view illustrations are for multiple models and not all parts shown are on all models. Every effort is made to supply accurate exploded views, however, due to interim changes in manufacturing operations, some units may not be exactly as illustrated.

Table of Contents

Complete Panel.....	3
Weight Tray.....	3
Wheel Guard Assembly.....	4
Hood Switch	4
Complete Spindle 115V.....	4
A & D Arm Assembly.....	5
Index Gauge.....	5
Electrical Schematic	6-7

Complete Panel

Item No	Part No.	Description
1	805PR032862	Touch Panel.....SPST
2	86103000014	Power Supply 24VDC.....SPST
3	867M100065B	Power BoardSPST
4	886SC026256	Processor CardSPST
5	85101000080	Rocker SwitchSPST

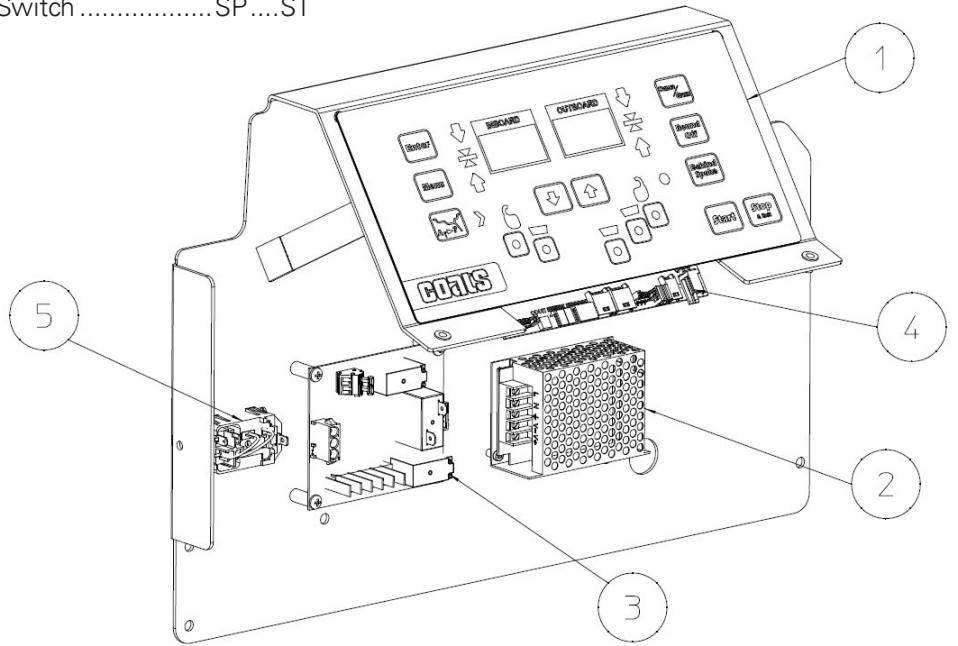

Weight Tray

Item No	Part No.	Description
1	814FB026139	Weight TraySP ... NS



NA **Not Available**
NS **Non-stocking**
SP **Service Part**
ST **Stock**

Wheel Guard Assembly

Item No	Part No.	Description
1	814FW019964	Wheel Guard..... SP... NS
2	818FW023250	Spring SP....ST
3	8217019275	Bushing..... SP....ST
4	842FW018279	Internal Pipe..... SP... NS
5	842FW018809	Wheel Guard Support..... SP... NS
6	842FW023266	Ring SP....ST
7	846FW003503	Ring with Magnet SP....ST

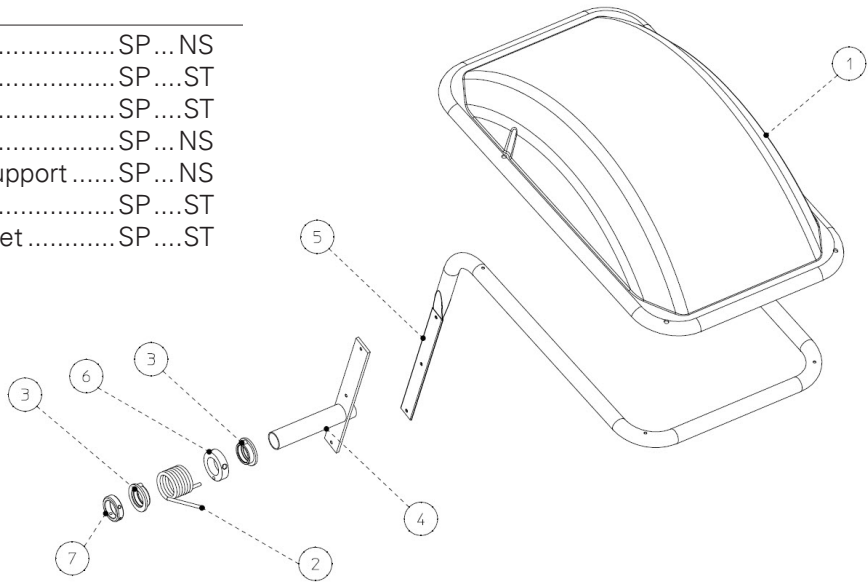

Hood Switch

Item No	Part No.	Description
1	886SB024679	Magnetic Switch..... SP....ST
2	886SB024680	Magnetic Switch..... SP....ST

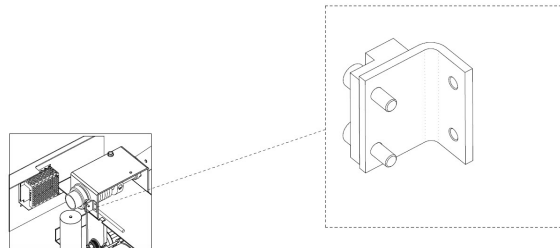

Complete Spindle 115V

Item No	Part No.	Description
1	8080048009	Belt SP....ST
2	842FB017240	Box..... NA
3	84RFM025709	Complete Shaft..... SP... NS
4	84RFM025711	Piezo Assembly..... SP....ST
5	850FG028933	Motor..... SP....ST

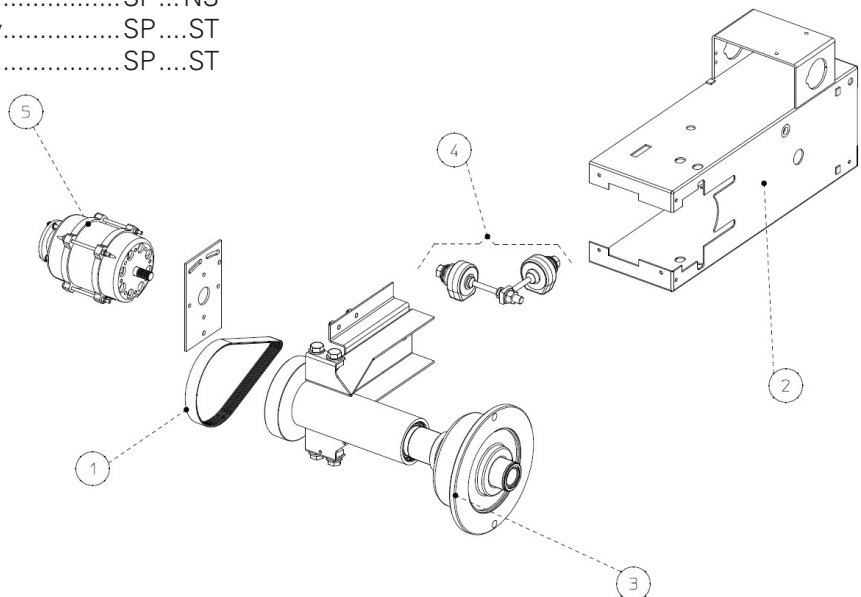

NA **Not Available**
NS **Non-stocking**
SP **Service Part**
ST **Stock**

A & D Arm Assembly

Item No	Part No.	Description
1	842FB018023	Bracket..... SP ... NS
2	842FC018024	Rod SP ... NS
3	886SB67291	Potentiometer..... SPST

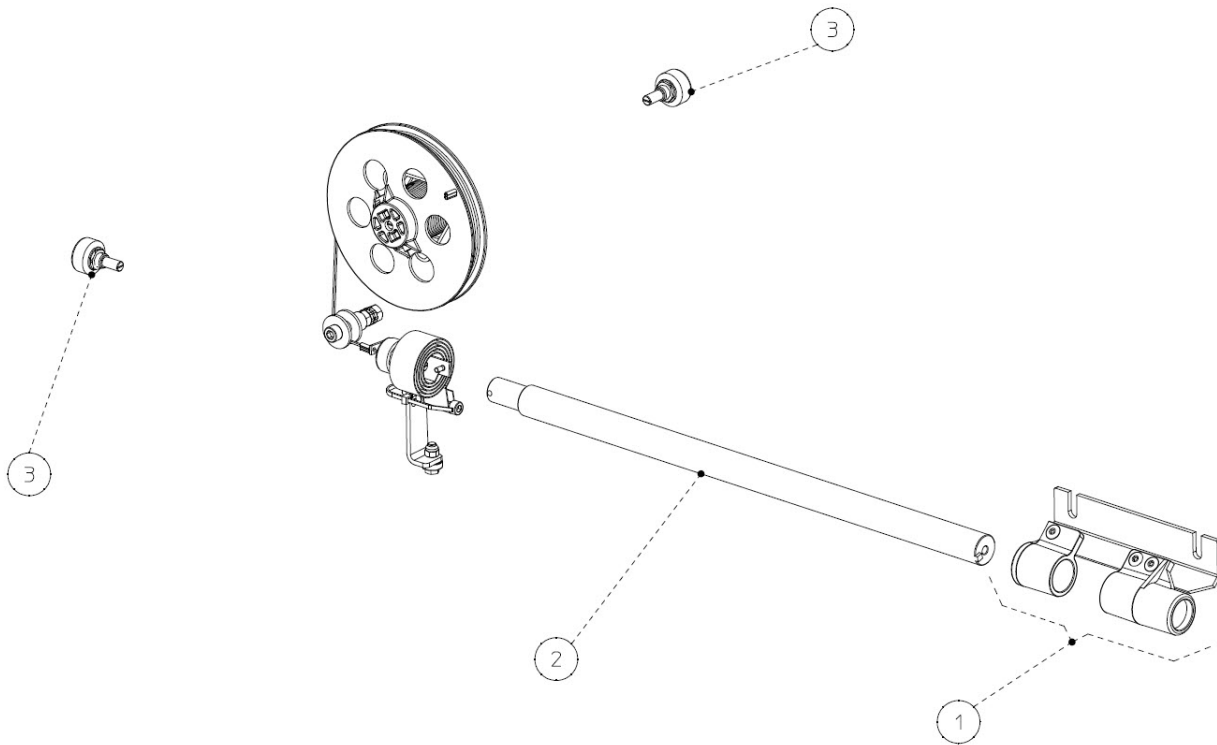

Index Gauge

Item No	Part No.	Description
1	8312120069	Screw NA
2	846FC92123	Arm-Gauge,Indx SP ... NS

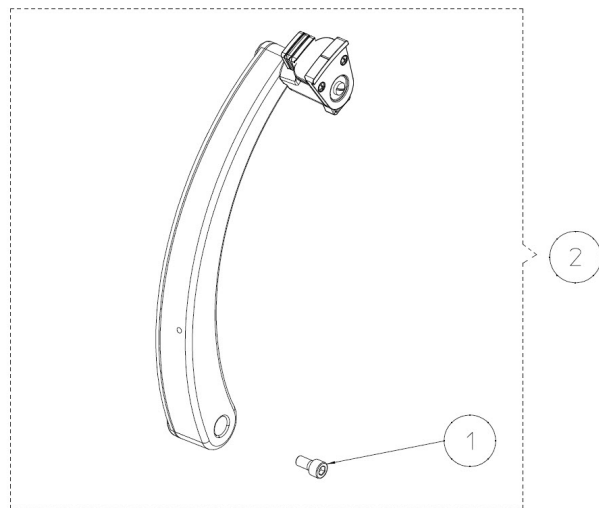

NA **Not Available**
NS **Non-stocking**
SP **Service Part**
ST **Stock**

Electrical Schematic

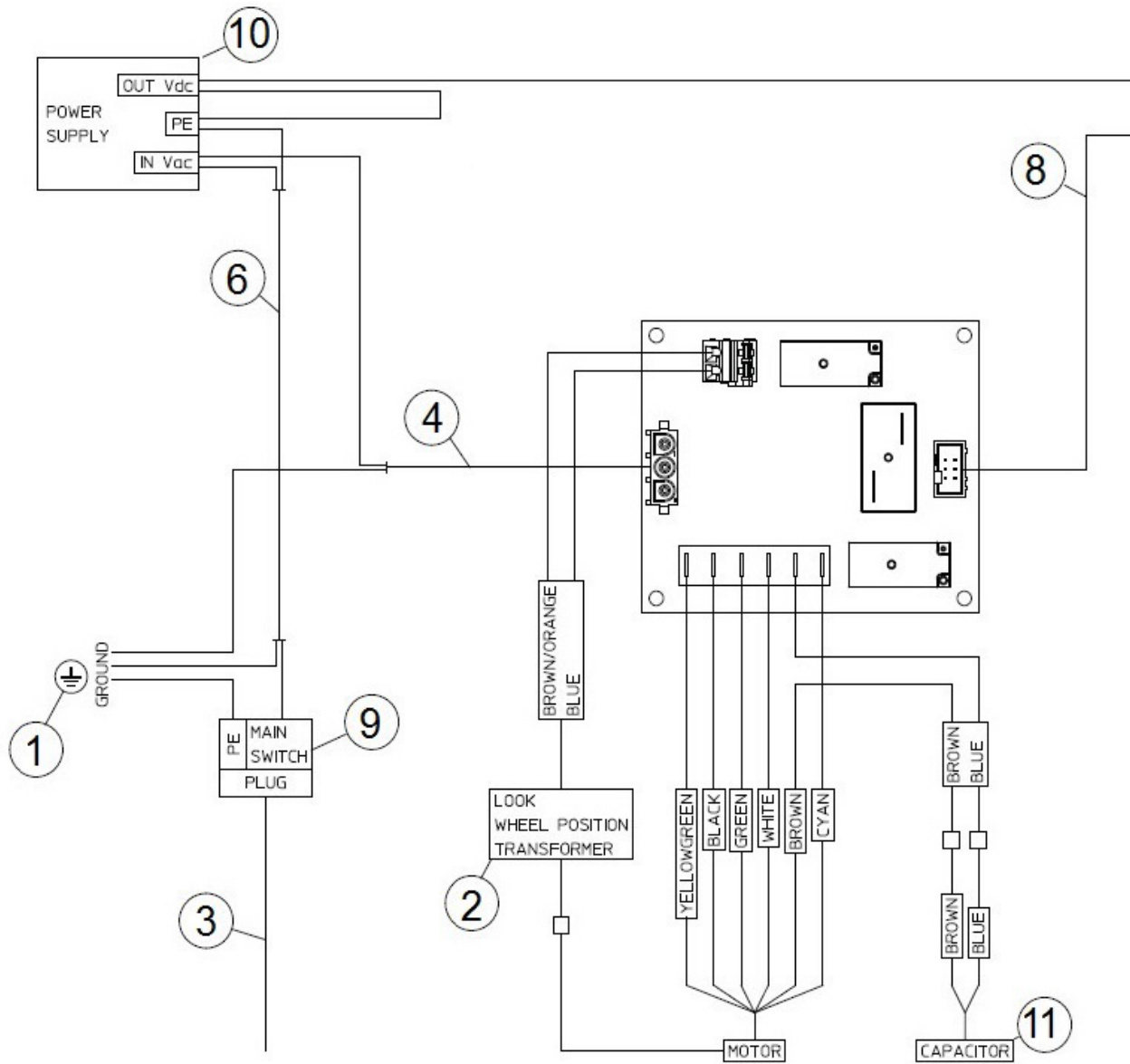

Item No	Part No.	Description
1	8040010095	Decal
2	8090100004	Transformer
3	886SB018249	Power Plug
4	886SB023270	Power Cable
5	886SB023271	Wiring, Power to PCB SP ST
6	886SB023272	Wiring, Power to MCB SP ST
7	886SB023372	Cable, Encoder SP ST
8	886SB023377	Cable, from MCB to PCB SP ST
9	886SB024790	Rocker Switch SP ST
10	86103000014	Power Supply, 100-230 VAC/5VDC
11	886SB031332	Capacitor
12	886SB67291	Potentiometers, Diameter or Distance

NA Not Available
NS Non-stocking
SP Service Part
ST Stock

Electrical Schematic

