

A DIVISION OF TSI

**AMERMAC™**

[www.buytsi.com](http://www.buytsi.com)

800.223.4540

# OPERATIONS MANUAL

## MODEL 501-A ELECTRONIC STROBE BALANCER

**READ** these instructions before placing unit in service **KEEP** these and other materials delivered with the unit in a binder near the machine for ease of reference by supervisors and operators

## Owner's Responsibility

To maintain machine and user safety, the responsibility of the owner is to read and follow these instructions:



MODEL 501-A ELECTRONIC STROBE BALANCER

- Follow all installation instructions.
- Make sure installation conforms to all applicable Local, State, and Federal Codes, Rules, and Regulations; such as State and Federal OSHA Regulations and Electrical Codes.
- Carefully check the unit for correct initial function.
- Read and follow the safety instructions. Keep them readily available for machine operators.
- Make certain all operators are properly trained, know how to safely and correctly operate the unit, and are properly supervised.
- Allow unit operation only with all parts in place and operating safely.
- Carefully inspect the unit on a regular basis and perform all maintenance as required.
- Service and maintain the unit only with authorized or approved replacement parts.
- Keep all instructions permanently with the unit and all decals/labels/notices on the unit clean and visible.
- Do not override safety features.

## Operator Protective Equipment

Personal protective equipment helps make tire servicing safer. However, equipment does not take the place of safe operating practices. Always wear durable work clothing during tire service activity. Loose fitting clothing should be avoided. Tight fitting leather gloves are recommended to protect operator's hands when handling worn tires and wheels. Sturdy leather work shoes with steel toes and oil resistant soles should be used by tire service personnel to help prevent injury in typical shop activities. Eye protection is essential during tire service activity. Safety glasses with sideshields, goggles, or face shields are acceptable. Back belts provide support during lifting activities and are also helpful in providing operator protection. Consideration should also be given to the use of hearing protection if tire service activity is performed in an enclosed area, or if noise levels are high.

**FAILURE TO READ AND FOLLOW ALL WARNINGS AND INSTRUCTIONS IN THIS MANUAL CAN LEAD TO SERIOUS PERSONAL INJURY OR DEATH TO OPERATOR OR BYSTANDER.**

THE OWNER IS RESPONSIBLE FOR MAINTAINING THE OPERATION INSTRUCTIONS AND DECALS FOR OPERATOR REFERENCE.  
FOR ADDITIONAL COPIES, CONTACT TSISSG

# MODEL 501-A ELECTRONIC STROBE BALANCER INSTRUCTIONS

With flat side of pick-up unit toward wheel and cord toward center of vehicle and running out the back of the wheel, adjust down to first mark on pick up unit but never down to second mark. Adjust jack up but never down with pick up unit underneath vehicle.

Mark tire anywhere or use valve stem as a reference point. Spin wheel on static switch and notice where reference point is with worst vibration with spinner away from wheel, switch to dynamic and notice where reference point is.

If 1 hour difference between two points all weight inside.

If 2 hour difference most weight inside.

If beyond 2 hours (or no dynamic flash at all) all the weight goes outside the wheel.

You are thru with dynamic switch from then on. This has told you all weight inside, most weight inside or all weight outside. Turn wheel back to static reference point and apply weight where spinner touches the wheel (at 4 o'clock or eight o'clock) depending on which side of vehicle you are on. (always just below dead center in direction wheel is turning) Dead center is nine and three o'clock.

On next spin you are looking for location of weight, always shift or add toward the spinner. On left front, suppose you saw the wheel weight at six o'clock and bad vibration, shift weight toward eight o'clock ( or toward spinner), if you saw weight at eight o'clock and had vibration add weight. If you saw weight at two o'clock you are too heavy, reduce weight. Make the light go out. For the perfectionist you can rest your hand on the vehicle and make the unit flash whether it wants to or not.

## FORWARD:

In order to achieve the best possible results while balancing a tire, there are certain inspections that must be performed by the operator. The checks listed below should not be omitted in any circumstance.

1. The vehicle must be lifted correctly. When lifting front straight axles lift only one wheel at a time by the frame or frame pads. When lifting Twin "I" Beams place jack under radius arm behind wheel to be balanced, when lifting independent front suspensions, lift from the center of the cross member, with both wheels suspended. All wheels to be balanced should be lifted approximately 4 inches above the floor.
2. Check tire tread for extreme wear and remove debris from tread. Check for recommended air pressure.
3. Wheel and axle bearings should not be loose. Loose bearings should be adjusted or replaced if necessary.
4. Check brakes for excessive drag and repair or replace.
5. Suspension should be checked for loose parts and adjusted if necessary.
6. Remove all wheel weights on wheel assemblies to be balanced.

# MODEL 501-A ELECTRONIC STROBE BALANCER INSTRUCTIONS

## WHEEL BALANCING INSTRUCTIONS FOR PASSENGER CAR FRONT WHEELS.

Kenetic method

### STEP 1:

Jack car per instructions to required height,

### STEP 2:

Install pick-up unit under ball joint or axle as close to wheel as possible in a vertical position with all three feet solidly on the floor. SEE ILLUSTRATION.

**CAUTION:** Pick-up cord should be in safe position from under tire and out of way of contact with spinning surfaces.

### STEP 3:

Pick-up unit should be compressed approximately 1/2" inch (any position between the two scribed marks). SEE ILLUSTRATION.

### STEP 4:

Plug light cabinet into 110 volt power supply. Switch to static. (98% of all vibrations can be cured by the following method.) Dynamic selector need not be used unless problem cannot be cured by the following method. If problem still persists, refer to dynamic instructions in Section 111.

### STEP 5:

Spin wheel, disengage spinner. Note location of reference mark (valve stem or chalk mark) on tire. Remember mark in terms of clock location. Stop wheel, reposition reference mark to same location as noted while spinning. SEE FIGURE 1.

### STEP 6

Place 1-5 oz. weights (depending upon severity of vibration) on inside of tire at location of spinning bell. SEE FIGURE 2

(Spinning bell is portion of tire spinner which rotates the tire. )

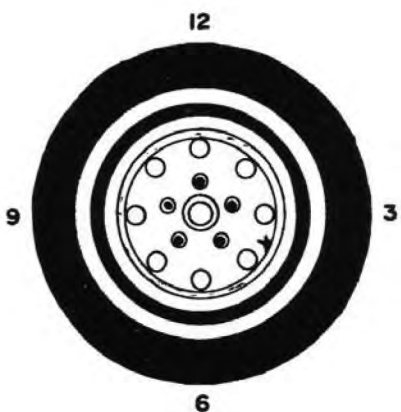
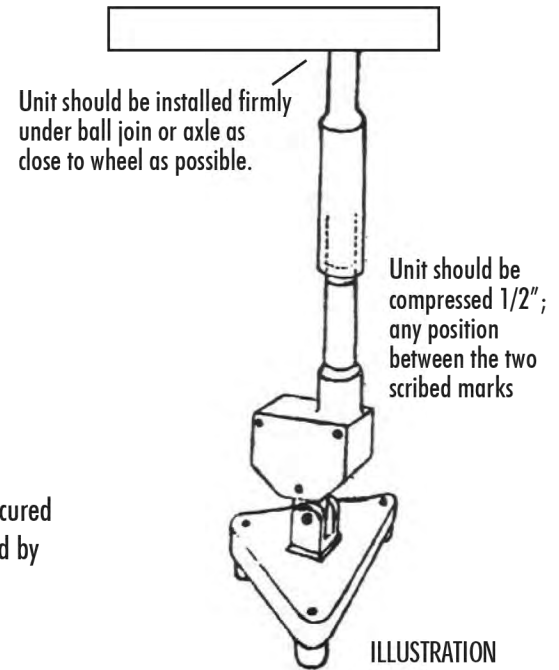
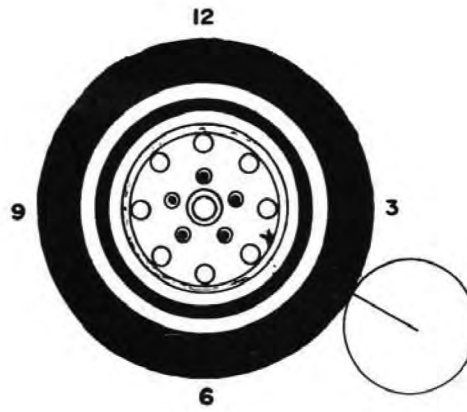

FIGURE 1



RH WHEEL

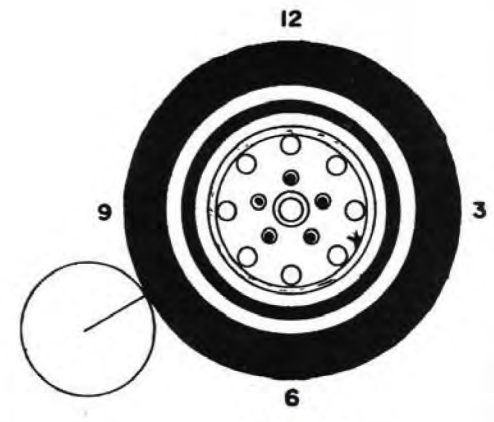

FIGURE 2

LH WHEEL

# MODEL 501-A ELECTRONIC STROBE BALANCER INSTRUCTIONS

## STEP 7:

Repeat Step 5. Also note location of inside weight. If location of inside weight is more than 3 hours (90° degrees) away from spinning bell, in either direction move weight half the distance to the bell and repeat Step 5 SEE FIGURE 3, If not, proceed with Step 8.

## STEP 8:

Attach 1-3 ozs. of weight on outside of tire at location of spinning bell. SEE FIGURE 4.

## STEP 9:

Repeat Step 5. If location of outside weight is above spinning bell, move downward toward bell, if location is below spinning bell move upward toward bell. SEE FIGURE 5.

## STEP 10:

Repeat Step 9 until desired objective is achieved (little or no vibration).

## SECTION 11- WHEEL BALANCING INSTRUCTIONS FOR PASSENGER CAR REAR WHEELS Kinetic Method

## STEP 1:

Block front wheels.

## STEP 2

Raise one wheel approximately 2" off the floor by placing a jack under the frame rail or body pad. Securely block remaining wheel on floor. Remove all rear wheel weights.

## STEP 3

Install pick-up unit under rear suspension as in STEP 2 of front wheel instructions, compress pickup unit as in STEP 3 of front wheel instructions.

## STEP 4

Plug light cabinet into 110 volt power supply, switch to static.

## STEP 5

Have driver stall the engine and shift into high gear or drive position and accelerate slowly. DO NOT exceed 35-40 MPH on speedometer reading. Note location of reference mark (valve stem or chalk mark) on tire. Remember mark in terms of clock rotation. Stop wheel., reposition reference mark to same location as noted while spinning.

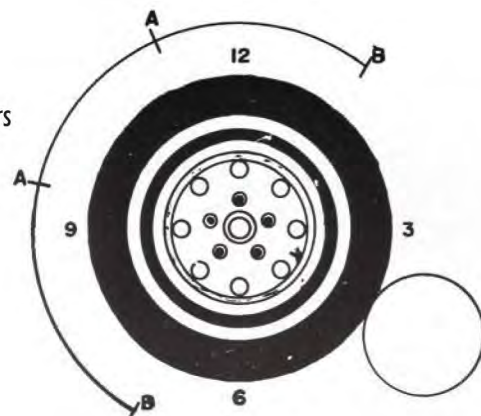

FIGURE 3

If location of inside weight is between A & B move weight half the distance toward spinning bell. If location of inside weight is between A & A decrease amount of weight.

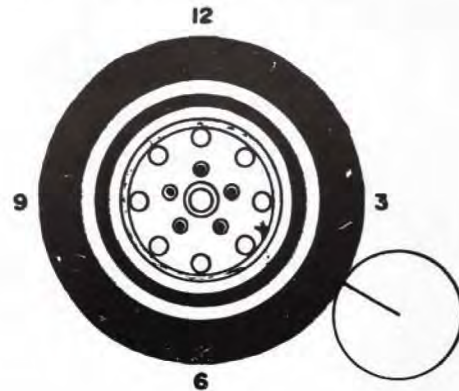

FIGURE 4

RIGHT HAND WHEEL  
Attach outside weight adjacent to spinning bell

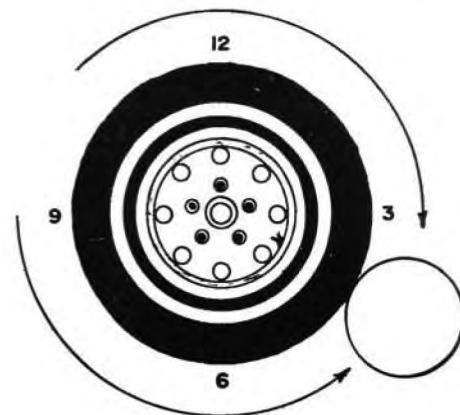
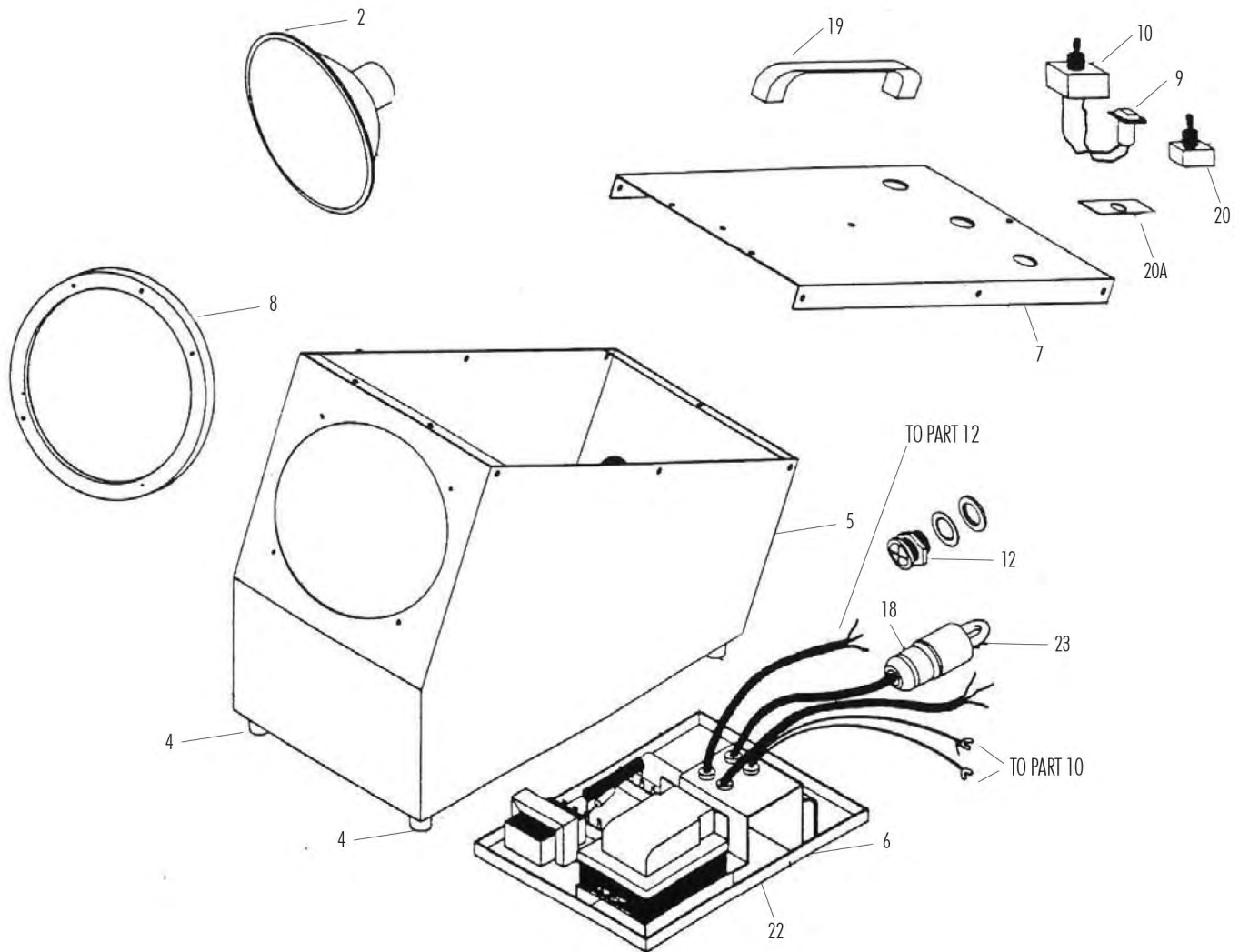

FIGURE 5

Move outside weight down if it appears above spinning bell, or up if below spinning bell.

# MODEL 501-A STROBE BALANCER



## PARTS

No.	Part Name	No.	Part Name	No.	Part Name	No.	Part Name
1	ACRYLIC LENS	7	20 GALLON STAINLESS STEEL TOP	14	1/4 - 20 x 1/2 SCREWS (4)	20	STATIC DYNAMIC SWITCH
2	ALUMINUM REFLECTOR	8	ALUMINUM RIM	15	#7 SHEET METAL SCREWS	20A	SWITCH PLATE
3	POWER CORD	9	INDICATOR LIGHT	16	10-24 x 3/8" SCREWS	22	POWER PACK
4	PLASTIC FEET (4)	10	ON/OFF SWITCH	17	8-32 SELF TAPPING SCREWS (2)	23	FLASH TUBE
5	22 GALLON METAL BODY	12	AMPHENOL, FEMALE	18	THREE PRONG PLUG		
6	20 GALLON STEEL SUPPORT/POWERPACK	13	HEYCO CONNECTOR	19	HANDLE		

# MODEL 501-A PICK-UP UNIT

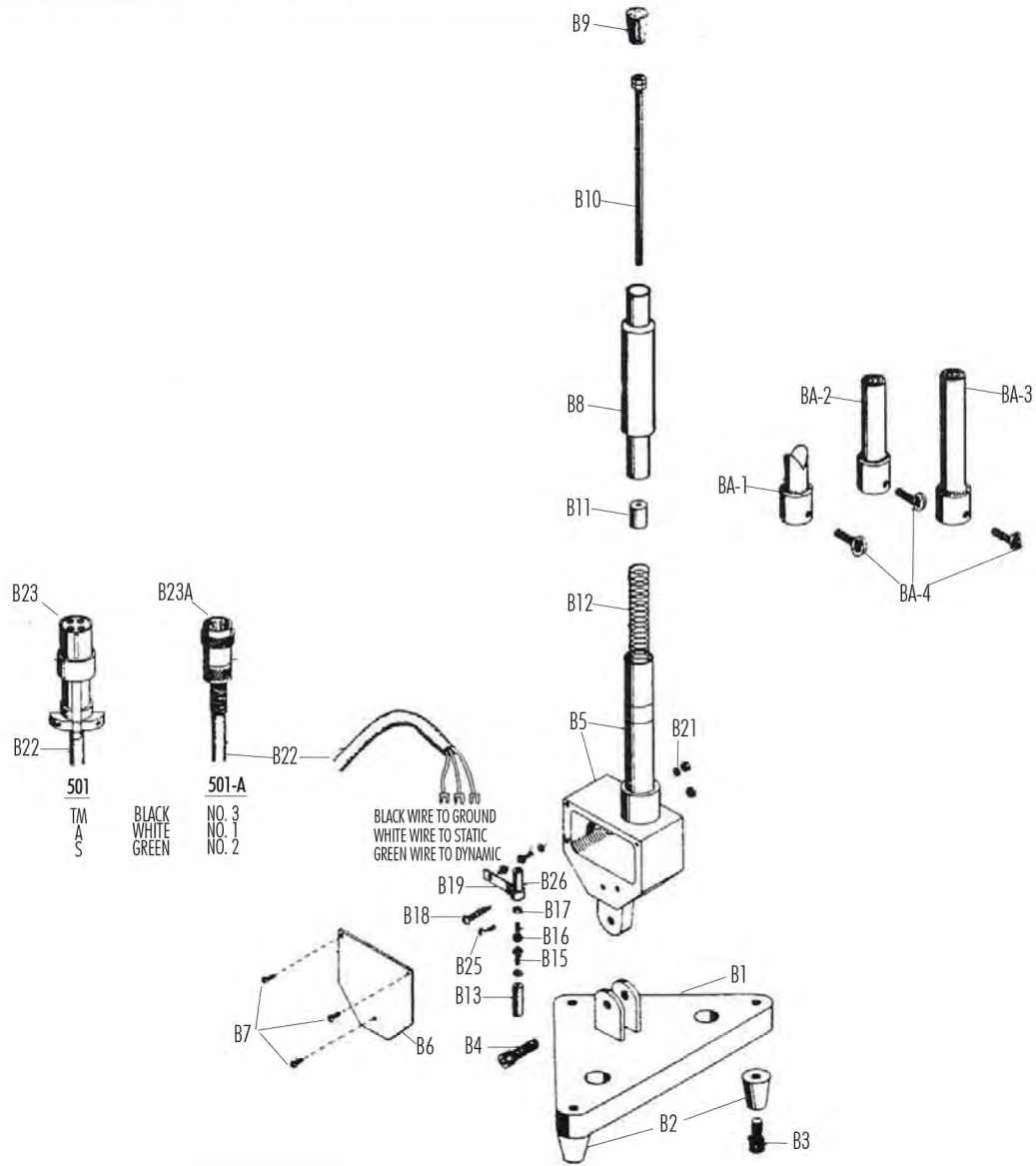

## PARTS

No.	Part Name	No.	Part Name	No.	Part Name	No.	Part Name
B1	BASE WITHOUT FEET	B9	DUST STOPPER	B17	ADJUSTING NUT	B24	CABLE SCREW
B2	PLASTIC FEET	B10	PUSH ROD WITH NUTS	B18	DYNAMIC LIMITING SCREW	B25	GROUNDING SCREW
B3	SOCKET SCREW	B11	BRONZE CLUTCH	B19	DYNAMIC ARM	B26	STATIC DYNAMIC BUSHING
B4	PIVOT BOLT	B12	SPRING	B20	DYNAMIC POINT WITH NUT	BA-1	1" DUCKBILL EXTENSION
B5	POINT BOX ASSEMBLY	B13	POINT SUPPORT	B21	FIBER BUSHING	BA-2	2" EXTENSION
B6	COVER	B14	RETAINER BOLT	B22	3-WIRE CABLE (16-3 SJ x 8FT)	BA-3	3" EXTENSION
B7	COVER SCREWS	B15	LOWER STATIC POINT	B23	BERG PLUG FOR 501	BA-4	THUMB SCREW
B8	UPPER SLEEVE ASSEMBLY	B16	UPPER STATIC POINT	B23-A	AMPHENOL PLUG FOR 501-A		

# Warranty Statement & Return Policy

Warranty & Workmanship you can depend on.

TSISSG products are designed and developed by experts in their respective industries. Our passion for designing and testing is second only to our drive for creating industry innovations and real world solutions which our customers can depend upon. With over 25 years of manufacturing experience we maintain the ability to provide competitive prices while employing and manufacturing in the USA. We are the manufacturer of the majority of our products so taking pride in workmanship and standing behind each and every product is not just our claim but our uncompromising responsibility.

TSISSG equipment is warranted to be free from defects in materials and workmanship for a period of one year from the date of original purchase to the original owner. Repair labor is warranted for 90 days from the date of original purchase. Bushings, blades, bearings and normal wear and tear are not covered under warranty. Careless handling, negligence, misuse, abuse, mutilation, improper operation, making unauthorized repairs, additions, and or alterations automatically cancel this warranty and relieves TSISSG of any obligation. Cheetah tanks claimed to be defective while under warranty will be evaluated at our manufacturing plant and either repaired if possible or exchanged and returned or credit issued to the customer account at our discretion. Damage resulting from dropping the tanks will not receive warranty consideration. Warranty parts need to be returned prepaid to the plant for credit. Any replacement parts shipped from the plant will be shipped at the customer's expense. Machines requiring warranty work must be brought to the manufacturing plant in Monticello, MN or to a repair facility authorized by TSISSG.

## Return Policy:

!!WARNING!! Goods returned without an RGA will be refused. A Returned Goods Authorization form must be obtained before returning any material or goods. All non-warranty returns will be subject to a 15% restocking fee plus any additional charges for reconditioning/repacking.

