

4-POST ALIGNMENT RACKS

AR4115 SERIES SITE SPECIFICATIONS



BAY HEIGHT: 78" rise + vehicle height
BAY WIDTH: 12' recommended
BAY DEPTH: 24' recommended/26'
 recommended for extended models
POWER REQUIRED: 208-230v Single
 Phase*, 30-amp breaker

AIR REQUIRED: 90-120 psi
MIN. CONCRETE SPEC:
 4" thick, reinforced, free from cracks/
 seams, rated at 3500+ psi, cured at
 least 28 days

SERVICE BAY LAYOUT

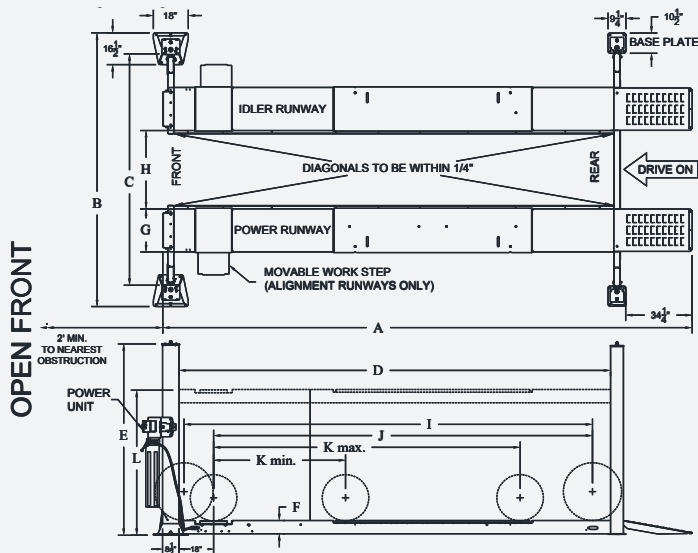

Model Number	AR4115EAO	AR4115XAO	AR4115EAX	AR4115XAX
Description	Standard, Open-Front, Alignment Deck	Extended Length, Open-Front, Alignment Deck	Standard, Closed-Front, Alignment Deck	Standard, Closed-Front, Alignment Deck
Lifting Capacity	15,000 lbs.	15,000 lbs.	15,000 lbs.	15,000 lbs.
Open or Closed Front	Open	Open	Closed	Closed
Maximum Wheelbase	183"	210.5"	183"	210.5"
Maximum 2-Wheel Alignment	167.75"	195.25"	167.75"	195.25"
Maximum 4-Wheel Alignment	68" - 158"	68" - 158"	68" - 158"	68" - 158"
Rise Height	78"	78"	78"	78"
Overall Length	250.75"	277"	247.625"	275.5"
Overall Width	Front: 142" Rear: 141.75"	Front: 142" Rear: 141.75"	141.75"	141.75"
Inside Columns (Left to Right)	Front: 120.75" Rear: 125.5"	Front: 120.75" Rear: 125.5"	125.5"	125.5"
Between Columns (Front to Rear)	195"	222.5"	196"	223.5"
Height of Columns	Front: 99.25" Rear: 98"	Front: 99.25" Rear: 98"	98"	98"
Width of Runways	22.375"	22.375"	22.375"	22.375"
Height of Runways	7"	7"	7"	7"
Width Between Runways	40.625"	40.625"	40.625"	40.625"
Air Supply Required	90-120 psi	90-120 psi	90-120 psi	90-120 psi
Standard Motor/Voltage*	3HP, 208v-230v, 60Hz, 1Ph	3HP, 208v-230v, 60Hz, 1Ph	3HP, 208v-230v, 60Hz, 1Ph	3HP, 208v-230v, 60Hz, 1Ph
Rise Time	85s	85s	85s	85s
Required Ceiling Height	14' x 24'	14' x 26'	12' x 24'	12' x 26'
ALI Certified	✓			
Available Colors				

* Lift capacity ratings are based on loads equally distributed on all four arms.

Alignment Rack includes movable work steps, (2) RJ7.5 jacks, recessed stainless steel turn tables, rear slip plates and airline kit