

OPERATOR'S MANUAL

Model 10876/10877/10878



1/2Gallon / 5Quart / 2Gallon
AIR HYDRAULIC FOOT PUMP

SPECIFICATIONS

Model	Input Air Pressure (psi)	Input Port Threads (NPT)	Output Port Threads (NPT)	Oil Delivery (cu.in./min)		Internal Relief Setting (psi)	Reservoir Capacity	Usable Oil Capacity (cu.in.)	Weight (lbs.)	L*W*H
				0 psi	10,000 psi					
10876	90-140	1/4"-18	3/8"-18	24.4	7.3	10,000	1/2 Gallon	98	19	10.3X5.3X7.3
10877	90-140	1/4"-18	3/8"-18	24.4	7.3	10,000	5 Quarts	275	28	12.5X7X7.5
10878	90-140	1/4"-18	3/8"-18	24.4	7.3	10,000	2 Gallon	442	36	11X8.8X10

DESCRIPTION

This Air/Hydraulic Pump supplies hydraulic fluid pressure to selected tools. It consists of an in-line air and hydraulic cylinder. The ratio of hydraulic fluid pressure generated compared to supply air pressure is 100:1. In other words, 100 PSI out for every 1 PSI in - 100 PSI input air pressure equals 10,000 PSI output pressure.

Depressing the RELEASE pedal causes a decrease in pressure and pressing the PUMP end of the pedal provides fluid pressure.

WARNING

The air/hydraulic pump is capable of generating fluid pressure up to 10,000 PSI. Make certain the tool in use is held securely and is in proper working condition. Do not continue to operate the pump once the work is completed. Failure to comply with these instructions could result in personal injury or damage to the equipment.

BEFORE USE

To prevent oil leak during shipment, a metal knob is installed and tightened to ensure the best sealing function. Loosen it counterclockwise before use.

Note: Always secure threaded port connections with non-hardening pipe thread compound. Tighten securely to prevent accidental removal of components while in use. Take care not to introduce compound into port orifices. Familiarize yourself with the specifications and illustrations in this operator's manual. Know your pump, its limitations and how it operates before attempting to use. Refer to Specification chart on above for details of oil port thread size, usable oil capacity, and more.

OPERATION

Operation of the unit is as follows:

1. Connect the hose of the Air/Hydraulic Pump to the hydraulic coupling on the selected tool.
2. Connect the air supply line to the Air/Hydraulic Pump. Air supply should be 5-10 CFM at 100 PSI to obtain proper operating characteristics. In addition, the air line should be equipped with an air line filter.
3. Stepping on the PUMP end of the pedal engages the pump, producing the force necessary to run the tool.
4. Depressing the RELEASE end of the pump pedal will release the pressure.

MAINTENANCE

1. Inspect hoses and connections daily.
2. Tighten connections as needed. Use non-hardening pipe thread compound when servicing connections.
3. Use only good quality hydraulic fluid. We recommend Mobil DTE 13M or equivalent.

When not in use or during storage:

- a. Depressurize and disconnect hydraulic hoses from application.
- b. Wipe clean, thoroughly.
- c. Store in clean, dry environment. Avoid temperature extremes.
- d. Shield pump with a protective cover.

Adding Hydraulic Fluid

1. Depressurize and disconnect hydraulic hose from application.
2. With pump in its upright, horizontal position, remove the oil filler plug located on the top plate of the reservoir.
3. Use a small funnel to fill reservoir to within 3/4"(19mm) of the opening.

Note: Use only good quality hydraulic jack oil.

Never use brake fluid, transmission fluid, turbine oil, motor oil, alcohol, glycerin etc. Use of other than good quality hydraulic oil will void warranty and damage the pump, hose, and application.

4. Wipe up any spilled fluid and reinstall the oil filler plug.

Changing Hydraulic Fluid

1. For best results, change fluid once a year.

2. Repeat # 2 above, then pour used fluid into a sealable container.

3. Dispose of fluid in accordance with local regulations.

4. Fill with a good quality hydraulic jack oil as recommended above. Reinstall vented oil filler plug.

Lubrication

Use a light machine oil to lubricate pivot points, hinges etc.

Note: Never operate pump with release valve closed and disconnected from application. If operated in this condition, the hose and connections become pressurized. This increases burst hazard. Damage may occur to pump and its components.

Parts List of Air/Hydraulic Pump

Item No.	Description	Q'TY	Item No.	Description	Q'TY	Item No.	Description	Q'TY
1	oil reservoir	1	31	rear cover	1	61	screw	12
2	oil filter	1	32	O-ring	1	62	O-ring	2
3	oil filter	1	33	O-ring	1	63	oil filler plug	1
4	valve block	1	34	bolt	1	64	oil filler plug	1
5	screw	1	35	fixing base	1	65	screw	1
6	spring	1	36	O-ring	2	66	oil filter	1
7	ball seat	1	37	O-ring	1	67	O-ring	1
8	steel ball	1	38	O-ring	1	68	O-ring	1
9	safety valve	1	39	spring	1	69	exhaust muffler	1
10	bolt	8	40	ball seat	1	70	fixing base	1
11	copper washer	1	41	steel ball	1	71	bolt	4
12	pump cylinder	1	42	O-ring	1	72	spring	1
13	Y-seal	1	43	nylon gasket	1	73	snap ring	2
14	nylon gasket	1	44	release valve	1	74	shaft	1
15	copper washer	1	45	ball seat	1	75	foot pedal	1
16	nut	1	46	spring	1	76	O-ring	1
17	spring	1	47	O-ring	1	77	screw	1
18	O-ring	1	48	release rod	1	78	air valve	1
19	air pump housing	1	49	O-ring	4	79	spring	1
20	washer	1	50	steel ball	1	80	seal	1
21	pump plunger	1	51	spring	1	81	bolt	2
22	air piston base	1	52	steel ball	1	82	air valve rod	1
23	O-ring	2	53	spring	1	83	O-ring	1
24	air shuttle valve	1	54	O-ring	1	84	O-ring	1
25	O-ring	2	55	nylon gasket	1	85	seitch coupler	1
26	piston	1	56	coupler	1			
27	bolt	3	57	nylon gasket	1			
28	shuttle valve seal	1	58	O-ring	1			
29	O-ring	2	59	seal	1			
30	O-ring	1	60	cover	1			

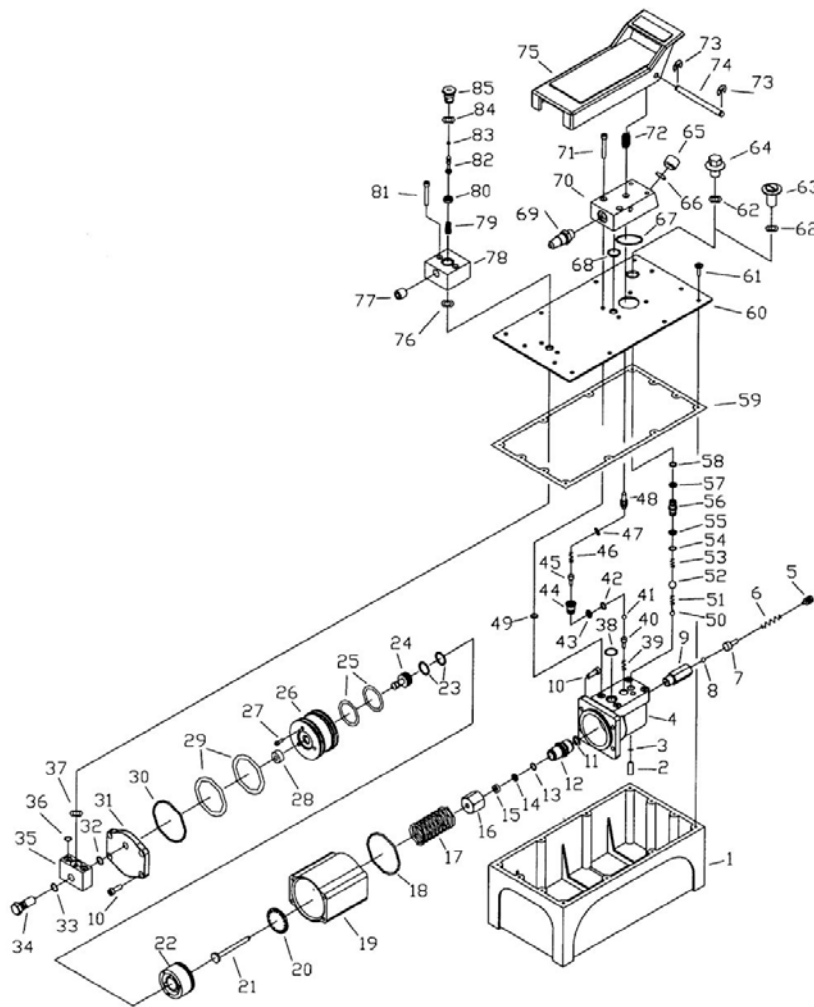

TROUBLESHOOTING

Symptom	Possible Causes	Corrective Action
Application will not extend, move or respond to pressurized fluid	<ul style="list-style-type: none"> • Overload condition • Release valve not closed 	<ul style="list-style-type: none"> • Remedy overload condition • Ensure release valve closed
Application responds to pressurized fluid, but system does not maintain pressure	<ul style="list-style-type: none"> • Overload condition • Release valve not closed • Hydraulic unit malfunction 	<ul style="list-style-type: none"> • Remedy overload condition • Ensure release valve closed
Application will not return fluid to pump (i.e. cylinder will not retract)	<ul style="list-style-type: none"> • Malfunctioning coupler, damaged application • Reservoir overfilled 	<ul style="list-style-type: none"> • Secure load by other means. Open release valve, depressurize pump and hose, remove coupler and/or application, then renew or replace • Secure load by other means. Open release valve, depressurize pump and hose, remove application, then drain fluid to proper level
Application will not fully extend (cylinder or spreader)	<ul style="list-style-type: none"> • Fluid level low • Fluid level low 	<ul style="list-style-type: none"> • Follow Symptom 3 procedure for securing load, depressurizing pump, remove application, then ensure proper fluid level
Poor performance	<ul style="list-style-type: none"> • Air trapped in system 	<ul style="list-style-type: none"> • Ensure proper fluid level • Ensure vented oil filler plug let pressurized reservoir air escape (see Before Use)