



PRO
SERIES

EQUIPMENT SUPPLY COMPANY

INSTRUCTION MANUAL

ESC3000 OTR GIANT TIRE BEAD BREAKER

MODEL(S) 10144 & 10144K



COPYRIGHT © 2023 EQUIPMENT SUPPLY CO., ALL RIGHTS RESERVED

Thank you for choosing ESCO tire service tools and equipment. We suggest you read this instruction manual thoroughly before using the product. Save this instruction manual for future use.

TABLE OF CONTENTS

- Introduction.....2
- Specifications.....2
- General Safety Rules.....3
- Operating Instructions.....4-8
- Troubleshooting.....8
- Parts Breakdown 9-10
- Model Number 10144.....9
- Model Number 10144K.....10
- Parts and Repair Service.....11
- Warranty..... 12

CAUTION!

Manual or Hydraulic Bead Breakers, and all tire tools, should be used only by persons properly trained according to OSHA regulation #29CFR1910.177, "Servicing Single-Piece & Multi-Piece

INTRODUCTION

The ESC3000 (Model 10144) Bead Breaker is used on 49 in. to 63 in. and larger multi-piece rims with pry bar pockets. The 10144 has a 6 in. stroke and is designed to break giant off-the-road tire beads on any rim. It can be used with a model 10518, 10592, 10594, or equivalent 10,000 psi [700 bar] pump. When working with 49 in. to 63 in. rims, use the OTR-1825D (10100) or OTR-1600 (10102) until you get enough room to install the 10144.

SPECIFICATIONS

MODEL NO.	CYLINDER CAPACITY	STROKE	Designed to be used on:
10144	25 TONS	6 in.	49 in to 63 in.*

*NOTE: Always consult with original tire and wheel equipment manufacturers suggested maintenance and service guides and warnings. These operating instructions do not apply to any specific rim. Therefore, contact the rim manufacturer for the correct procedure for your rim.

GENERAL SAFETY RULES

WARNING

- To avoid personal injury or property damage while using this product, read and follow all DANGERS, WARNINGS, CAUTIONS, and INSTRUCTIONS that are attached to, or included with, this product.
- To avoid serious personal injury, always wear proper protective gear, such as hard hats, safety glasses, gloves, and steel toe shoes when using hydraulic equipment.
- Follow the instructions of the tire manufacturer and the vehicle manufacturer when deflating, de-mounting, mounting, and inflating tires.
- These operating instructions do not apply to any specific rim. Therefore, contact the rim manufacturer for the correct procedure for your rim.
- For the publication, “Multipiece Rim Matching Chart” contact the United States Department of Labor, Occupational Safety, and Health Administration (OSHA), Washington, DC, 20210, 202-219-6091, or contact ESCO at 1-800-352-9852. If you are outside the U.S., contact your local government officials.
- ESCO cannot be held responsible for damage or injury resulting from unsafe use of this product, lack of maintenance, or incorrect product and system application.
- Contact ESCO when in doubt about safety precautions or applications.
- If the hydraulic bead breaker needs repairing and/or there are any parts that need to be replaced, have it repaired by authorized technicians and only use the replacement parts supplied by the manufacturer.
- **WARNING:** the warnings, cautions and instructions discussed in this instruction manual cannot cover all possible conditions and situations that may occur. It must be understood by the operator that common sense and caution are factors which cannot be built into this product, but must be supplied by the operator.
- **Always visually inspect the product before use for damage. Do not use product if damaged, altered, or in poor condition. Contact our technical service department with any questions or product issues by calling 800-352-9852.**

OPERATING INSTRUCTIONS



WARNING! Ensure that you read, understand and apply the safety instructions and warnings before use.



WARNING! Ensure that you have familiarized yourself thoroughly with the product and the hazards associated with its improper use.

REMOVING THE WHEEL

1. Chock the wheels opposite the jack.
2. Jack up the vehicle.
3. Crib the vehicle with safety stands or blocking devices after jacking it up. Do not work under an unblocked load.

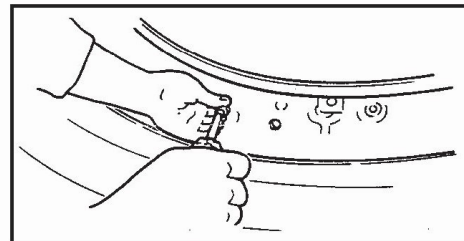

Figure 1



DANGER Failure to chock the wheels and crib the vehicle can result in serious injury or death.

4. Remove the valve core; deflate tires completely.,(See Fig. 1.)
5. Insert a thin piece of wire through the valve stem to make sure air is flowing freely and the valve stem is not blocked. NOTE: Deflate both tires if you have a dual mounting.

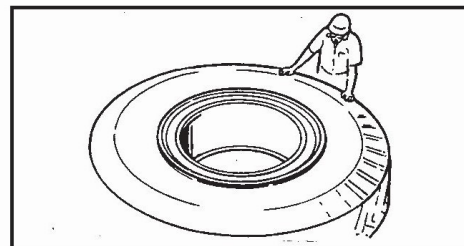

Figure 2



DANGER Always deflate tires before removing a wheel, a rim, or part of a rim, such as a rim clamp or nut. If you do not deflate the tire, the tire could explode, causing serious injury or death.

USING MODEL 10144 BEAD BREAKER

Positioning the Bead Breaker

1. Place the bead breaker into the continuous pry bar pocket, with the hooks under the lip of the bead seat band. (See Fig. 3.)
2. Position the bead breaker so that it is about 30°, or at least 12 inches [0,3 m], to one side of the flange butt weld.
3. Adjust the ram adjusting screw so that the bead breaker is perpendicular (90°) to the wheel. (See Fig. 3.) In some cases you may have to use an OTR-1825D (10100) or OTR-1600 (10105) to move the rim flange far enough back to insert the larger 10144 tool.
4. Stand to one side of the bead breaker. Hold the bead breaker with one hand. (See Fig. 4)

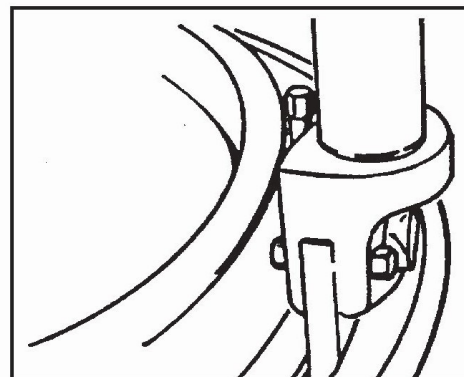

Figure 3



DANGER Always stand to one side of the rim when using the bead breaker. Standing to one side of the bead breaker allows you to maintain control of the bead breaker. If it is not seated properly and flies off the rim, the bead breaker could cause serious injury or death.

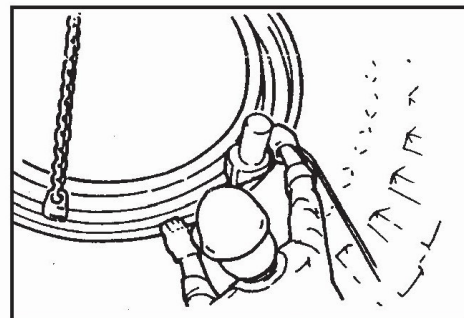

Figure 4

OPERATING INSTRUCTIONS

Activating the Bead Breaker



CAUTION The bead breaker uses a long stroke and high force. Be careful not to damage or bend rim parts, such as the flange butt weld, when using the bead breaker.

1. Turn on the hydraulic pump to activate the bead breaker.
2. Apply enough hydraulic pressure to the bead breaker to push the flange about 1/2-3/4 inch [13-19 mm] from the lip of the bead seat band.
3. If the bead breaker moves and is no longer vertical, readjust the ram adjusting screw. You must release pressure before adjusting the screw.
4. Continue applying hydraulic pressure until the flange is about 3/4-1 inch [19-25 mm] from the lip of the bead seat band.
5. Place a nut or similar object between the flange and the lip of the bead seat band. (See Fig. 5.)

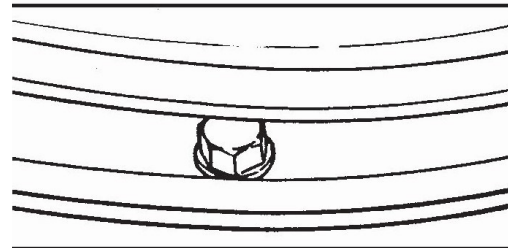

Figure 5



WARNING To prevent personal injury, lay the nut on the flange and slide it into position with two screwdrivers. DO NOT PUT YOUR FINGERS UNDER THE BEAD SEAT BAND.

6. Release hydraulic pressure.

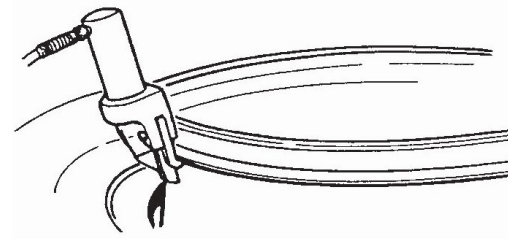

Figure 6

Continuing to Break the Tire Bead

1. Move the bead breaker away from the flange butt weld, 2-3 feet [0,5-1,0 m] from its present position.
2. Follow the steps in “Activating the Bead Breaker” above.
3. Continue advancing the bead breaker around the rim, 2-3 feet [0,5-1,0 m] at a time, breaking the tire bead.
4. Stop breaking the tire bead when you have moved the bead breaker about 3/4 of the way around the rim. (See Fig. 6.)

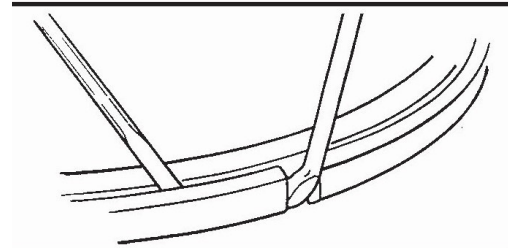

Figure 7



CAUTION To prevent damage to the rim, do not use the bead breaker within 12 inches of the flange butt weld.

5. Apply enough pressure to the bead breaker to completely break the tire bead.

6. Release the hydraulic pressure.

NOTE: If you have gone all the way around the tire and the tire bead does not break: Repeat the steps in “Activating the Bead Breaker” and “Continuing to Break the Tire Bead” above, with more hydraulic pressure.

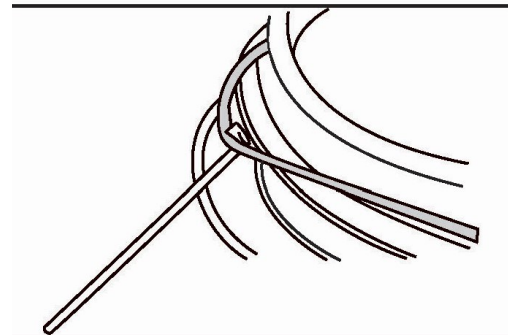

Figure 8

Removing the Lock Ring and O-Ring

1. Stand inside the tire rim. Remove the lock ring with two pry bars. Start at the split in the ring and then work the tools around the ring. (See Fig. 7.)
2. Place a pry bar or screwdriver under the o-ring and pull it out from the groove in the rim. Cut the o-ring with a knife to ensure that a new o-ring is used. (See Fig. 8.)

OPERATING INSTRUCTIONS

Removing the Bead Seat Band

1. Carefully lift the bead seat band off the rim. Use a hoist, pry bars, and the ESCO Flange Ring Puller Model 90300. (See Fig. 9.)
2. Carefully remove the flange from this side of the tire.
3. Using a hoist and ESCO Tire Sling Model 90100, turn the tire/rim assembly over on the other side.

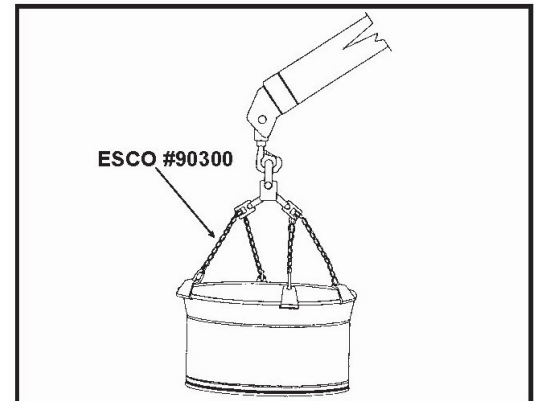

Figure 9

Breaking the Bead on the Other Side

1. Break the tire bead on this side of the tire by repeating the steps in USING MODEL 10144 BEAD BREAKER on pages 2 and 3.
2. Using a hoist, lift the rim base from the tire. Using the ESCO
3. Flange Ring Puller Model 90300 will make handling easier. (See Fig. 10.)
4. Remove the flange from this side of tire.

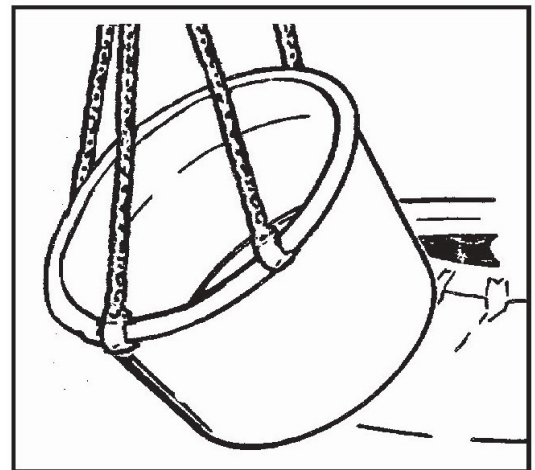

Figure 10

MOUNTING AND INFLATION

Jacking Up the Vehicle

1. Chock the wheels opposite the jack.
2. Jack up the vehicle.
3. Crib the vehicle with safety stands or blocking devices after jacking it up. **DO NOT WORK UNDER AN UNBLOCKED LOAD.**



DANGER Failure to chock the wheels and crib the vehicle can result in serious injury or death.

Inspecting the Tire and Rim



DANGER Always replace damaged or badly worn tires. When replacing tires, always use a replacement of exactly the same diameter. Destroy old tires, so that they cannot be used. Using badly worn or damaged tires can result in serious injury or death.

1. Inspect all rim parts for damage.



DANGER Always replace rim parts that are bent, badly rusted, pitted from corrosion, cracked, worn, or damaged. Destroy old rim parts, so they cannot be used. Using damaged rim parts can result in serious injury or death.

Do not mix parts from one rim with parts from another rim. Always use replacement parts that you can positively identify as the **CORRECT** replacement parts. All replacement rim parts **MUST** match the replacement part numbers stamped on the rim parts. Rims with different part numbers cannot be interchanged. If in doubt about sizing, **DO NOT** reassemble the rim. Contact the rim manufacturer for more information.

2. Replace damaged parts.



DANGER Never weld on an inflated or partially inflated tire/rim assembly. Welding on an inflated tire/rim assembly can cause an explosion and serious injury or death. Do not rework, weld, heat, or braze any rim parts for any reason. Reworking and welding damaged parts can result in serious injury or death.

OPERATING INSTRUCTIONS

3. Clean and repaint rim parts as necessary.

NOTE: Remove rust, dirt, and foreign material from rim parts. Repainting the rim parts and bare metal areas will make them last longer. Be careful to keep paint out of the lock ring groove in the gutter when repainting rim parts.

4. Visually inspect all tire and rim parts to make sure they are positioned properly.

Starting to Inflate the Tire

To comply with OSHA Regulation #29CFR1910.177, place the tire in a safety cage or other restraining device, such as an ESCO Push Bar Model 90201, before inflating the tire. Use a clip-on air chuck and hose that is long enough to allow you to stand outside the wheel trajectory. The air line must be equipped with an in-line valve with pressure gauge or regulator that can be preset. Use ESCO Truck Tire Inflator Model 10962L.



DANGER Always use a safety cage or restraining device, such as an ESCO Push Bar Model 90201, when inflating a tire. Not using a safety cage or restraining device can result in serious injury or death. Always use a clip-on air chuck and a hose that is long enough to allow you to stand outside the wheel trajectory. The air line must be equipped with an in-line valve with a pressure gauge and a regulator that can be preset.

Never use starting fluid, ether, gasoline, or any other flammable material to lubricate, seal, or seat the bead of a tubeless tire. Doing so can cause an explosion and serious injury or death.

2. Inflate the tire to 5 psi [0,345 bar].
3. Check all tire and rim parts again for proper positioning. Make sure the o-ring does not slip out of its groove.
4. If tire/rim parts are not seated properly, deflate the tire and correct the problem before proceeding.



WARNING Never hammer, strike, or pry an inflated or partly inflated tire/rim assembly. If you must seat a part or correct a problem, always deflate the tire first.



CAUTION Do not use a steel hammer on rim or rim parts. This can damage the rim. If you must reposition tire or rim parts, use a rubber, plastic, or brass-faced hammer.

If a tire/rim assembly does not slide over a cast spoke wheel, do not force the assembly by hammering. Instead, deflate the tire and inspect for warped or incorrectly seated parts, such as lock rings.

5. If tire and rim parts are seated properly, proceed to "Finishing the Tire Inflation" below.

Finishing the Tire Inflation

1. Inflate the tire to 20 psi [1,38 bar].
2. Check the tire bead for proper seating.
3. Continue inflating the tire to 40 psi [2,76 bar] If the tire bead is not fully seated, see the Warning below. If the tire bead is fully seated, continue with Step 4 below.



WARNING Never inflate a tire beyond 40 psi [2,76 bar] to seat a tire bead. If the tire bead is not fully seated at 40 psi: Stop! Deflate the tire and correct the problem.

OPERATING INSTRUCTIONS

4. Once you see that the tire bead is fully seated at 40 psi [2,76 bar], deflate the tire completely.
5. Reinflate the tire slowly to the manufacturer's recommended pressure.



DANGER Inflate and load tires only to manufacturer's specifications. Over-inflating and overloading tires can result in serious injury or death.

Never run a vehicle with only one tire of a dual assembly. Doing so can result in a collapse of the vehicle and lead to serious injury or death.

MAINTENANCE & VISUAL INSPECTION

MAINTENANCE

- Check the tools before their use. in case of oil leaks, replace the seals.
- For pump maintenance, see instruction manual or call ESCO at 352-754-1117 to find an authorized ESCO repair facility in your area.

VISUAL INSPECTION BEFORE EACH USE

- A visual inspection must be carried out every time you want to use ANY Bead Breaker or any other hydraulic tools and equipment.— Checking leaks, damages, missing or loose parts, worn parts, etc.
- All Bead Breakers must be carefully visually inspected and reviewed for any damage or potential loose or unworking components and parts.
- We suggest that a skilled personnel yearly check the bead breaker and that all defective parts, worn parts etc. are replaced by using original spare parts supplied by ESCO.

PARTS BREAKDOWN

FOR MODEL 10144:



ITEM #	PART #	DESCRIPTION	QTY
1	10310	Cylinder, 25T, 6 inch stroke	1
2	10144-2	Lower Jaw—Back Section	2
3	10144-3	Lower Jaw—Bead Band	2
4	10144-4	Bead Breaker Extension w/ 25 Ton Tilt Saddle	1
5	10144-5	3/4" Shoulder x 2" x 5/8-11 Screw	4
6	10144-6	Set Screw	2
7	10144-7	Clamp	2
8	10144-8	Bead Breaker Frame	1
9	10144-9	Hex Nut	2
10	10144-10	Locking Hex Nut	2

PARTS BREAKDOWN

FOR MODEL 10144K:

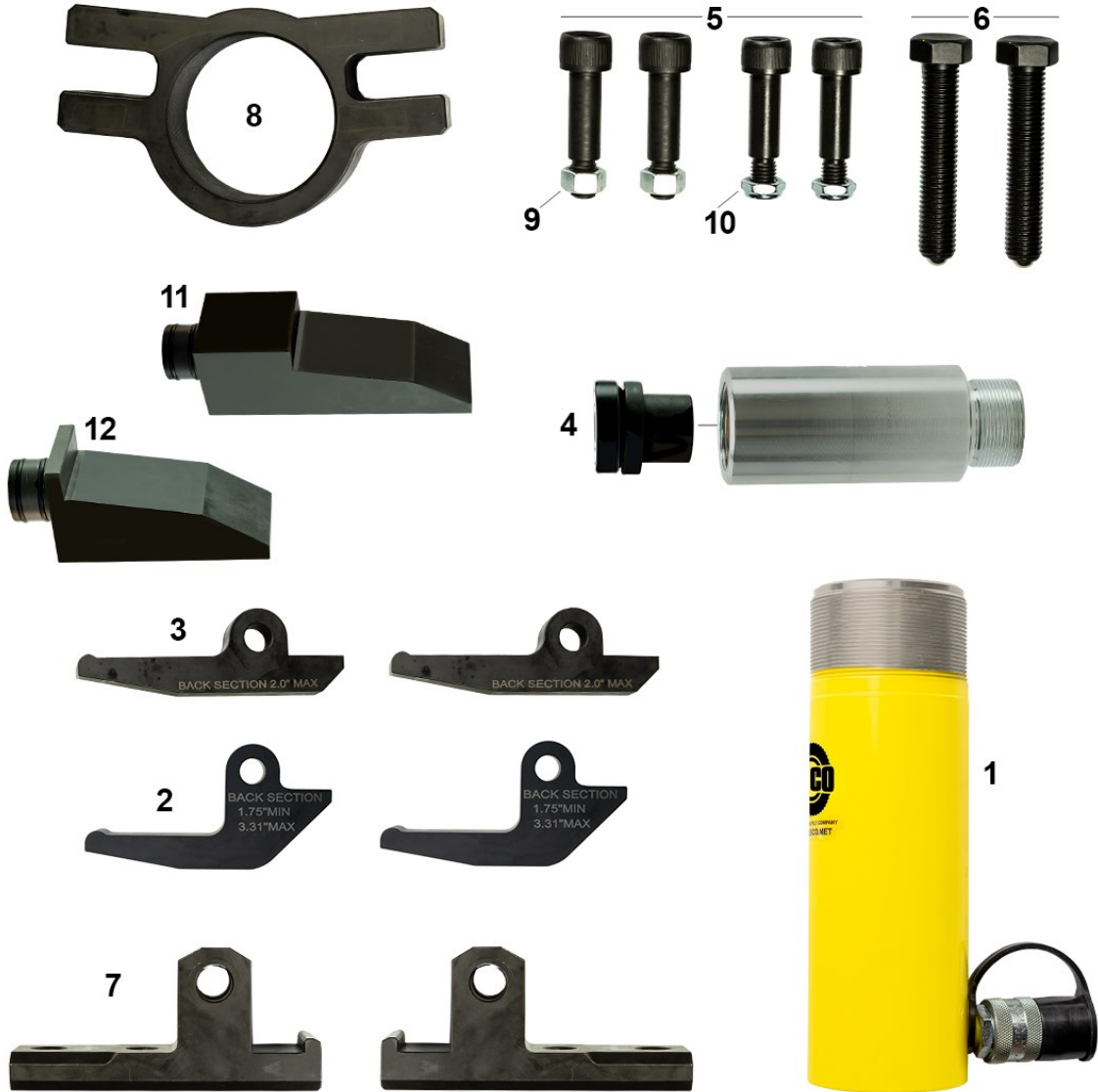

ITEM #	PART #	DESCRIPTION	QTY
1	10310	Cylinder, 25T, 6 inch stroke	1
2	10144-2	Lower Jaw—Back Section	2
3	10144-3	Lower Jaw—Bead Band	2
4	10144-4	Bead Breaker Extension w/ 25 Ton Tilt Saddle	1
5	10144-5	3/4" Shoulder x 2" x 5/8-11 Screw	4
6	10144-6	Set Screw	2
7	10144-7	Clamp	1
8	10144-8	Bead Breaker Frame	1
9	10144-9	Hex Nut	2
10	10144-10	Locking Hex Nut	2
11	10144-SPADE-XL	Extension Adapter for Titan Style SVM/OVM Wheels	1
12	10144-SPADE	Extension Adapter for Rimex DGS Wheels	1

PARTS AND REPAIR SERVICE

GUARANTEED 1-Day Turnaround Service.

Received by ESCO - Repaired in 24 Hours - Returned to you!

- ESCO will pick up product for repair/warranty at your location.
- ESCO will guarantee Repair/Service for 30 days.
- ESCO has rental tools available
- ESCO repairs IMT, FEC, Stellar, Blackhawk, OTC, Power Team, Ame Int., & Enerpac hydraulic pumps, bead breaker, and cylinders.
- Authorized ESCO Repair & Warranty Centers Located through the US & Canada. For more information contact your ESCO sales representative.
- Technical Support Over the Phone Available by Calling 1-800-352-9852

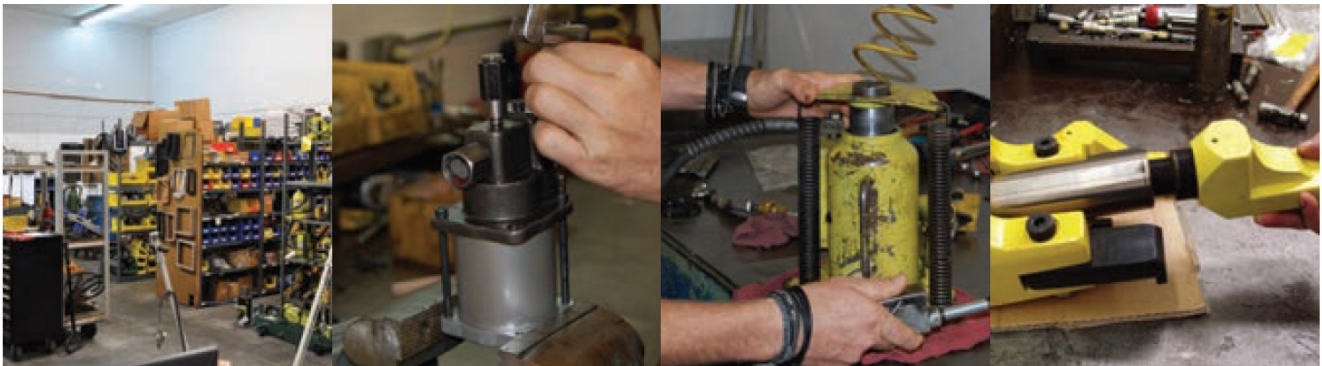

Prompt, reliable service after the sale is very important to ESCO. ESCO maintains an in-house repair facility in Brooksville, Florida. To insure that our customers have as little down-time as possible, we offer a 1 day turnaround service. Our factory repair service is equipped with all the tools and machinery needed to repair your equipment quickly and affordably. Our trained technicians are the best in the industry. Not only do we service our own products, but we also service our competitors' products.

In addition to ESCO's 30 years of providing quality repair service, ESCO has reached out and partnered with more than 50+ hydraulic repair facilities across the US & Canada, to deliver quality repair and timely return of products. Visit www.esco.net or call 1.800.352.9852 to hear more about the newly added "Authorized ESCO Warranty & Repair Facilities" across the US.

If you have a bead breaker, ram, or hydraulic pump that needs repair, ESCO fixes your product with factory parts and guarantees the repair. In addition to servicing ESCO brand products, we also re-pair CP, IMT, Elrick, Branick, Goodyear, FEC, AME Int., and Haltec lines of hydraulic bead breakers, rams, pumps, jacks, and many other hydraulic tire service equipment.

WARRANTY

Products sold by Equipment Supply Company (ESCO) are warranted to be free from defects in material and workmanship under proper use, application, and maintenance in accordance with ESCO's written recommendations, instructions, and specifications for a period of 1 year (365 days) from the date of shipment to the end user, unless otherwise noted. ESCO's obligation under this warranty is limited to, and the sole remedy for any such defect shall be the repair or replacement (at ESCO's discretion) of unaltered parts returned to ESCO, freight prepaid, and proven to have such defect, provided such defect occurs within the 90-day warranty period (or otherwise noted) and is reported within 14 days of occurrence.

This is the only authorized ESCO warranty and is in lieu of all other express or implied warranties or representations, including any implied warranties of merchantability or fitness. Warranty claims must be submitted and be processed in accordance with ESCO's established warranty claim procedure. In no event will ESCO be liable for business interruptions, loss of sales and/or profits, personal injury, costs of delay, or for any other special, indirect, incidental or consequential losses, costs, or damages.

PURCHASE DATE: _____

MODEL NO.: _____

SERIAL NO. (If Applicable): _____

NOTES:

Return to ESCO, 15270 Flight Plath Blvd. Brooksville, FL 34604

Or Visit www.esco.net/warranty



EQUIPMENT SUPPLY COMPANY

The Proper Tools To Keep Your Equipment **MOVING**



Scan this Code to Go to
the ESCO website

WWW.ESCO.NET

CONTACT INFO:
www.esco.net - info@esco.net
15270 Flight Path Drive
Brooksville, FL 34604
PH. 352.754.1117
Toll Free. 1.800.352.9852 (US, Canada Only) Fax: 352.754.4508



WARNING: Cancer and Reproductive Harm- www.P65Warnings.ca.gov

Stay Connected with ESCO....



COPYRIGHT © 2023 EQUIPMENT SUPPLY CO., ALL RIGHTS RESERVED

Thank you for choosing ESCO tire service tools and equipment. We suggest you read this instruction manual thoroughly before using the product. Save this instruction manual for future use.