



EUROPEAN USERS

400V 50Hz SUPPLY DETAILS ARE INCLUDED WITH ELECTRICAL CONTROL BOX. DISREGARD SUPPLY WIRING DETAILS IN THIS MANUAL

IMPORTANT SAFETY INSTRUCTIONS SAVE THESE INSTRUCTIONS

PLEASE READ THE ENTIRE CONTENTS OF THIS MANUAL PRIOR TO INSTALLATION AND OPERATION. BY PROCEEDING WITH LIFT INSTALLATION AND OPERATION YOU AGREE THAT YOU FULLY UNDERSTAND AND COMPREHEND THE FULL CONTENTS OF THIS MANUAL. FORWARD THIS MANUAL TO ALL OPERATORS. FAILURE TO OPERATE THIS EQUIPMENT AS DIRECTED MAY CAUSE INJURY OR DEATH.

Revision B – November 2020

Part Number 5900001

INSTALLATION AND OPERATION MANUAL

FOUR-POST OPEN FRONT ALIGNMENT LIFTS COMMERCIAL GRADE 14,000 LBS. CAPACITY

Models:

- HDSO-14P
- HDSO-14AX

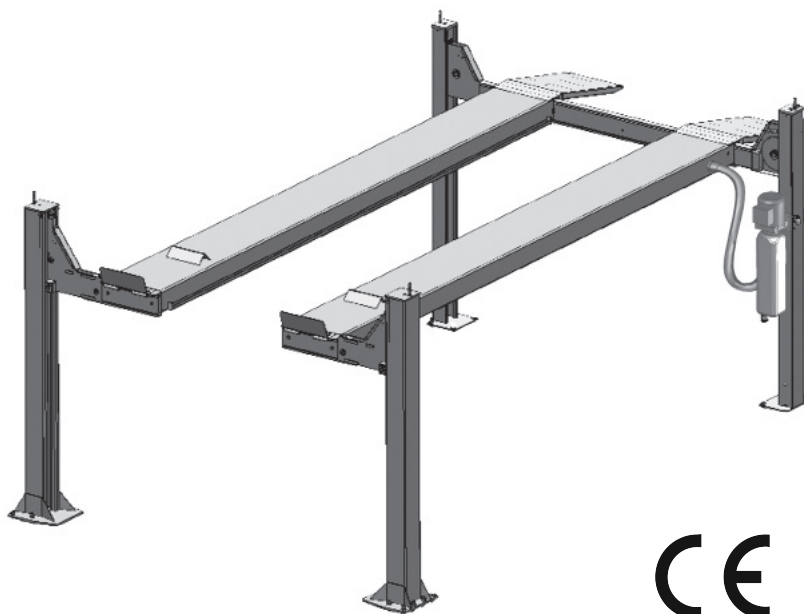

Keep this operation manual near the machine at all times. Make sure that ALL USERS read this manual.

RECEIVING

The shipment should be thoroughly inspected as soon as it is received. The signed Bill of Lading is acknowledgement by the shipping carrier as receipt of this product as listed in your invoice as being in a good condition of shipment. If any of these goods listed on this Bill of Lading are missing or damaged, do not accept goods until the shipping carrier makes a notation on the freight bill of the missing or damaged goods. Do this for your own protection.

BE SAFE

Your new lift was designed and built with safety in mind. However, your overall safety can be increased with proper training and thoughtful operation on the part of the operator. DO NOT operate or repair this equipment without reading this manual and the important safety instructions shown inside. Keep this operation manual near the lift at all times. Make sure that ALL USERS read and understand this manual.

14,000 POUND CAPACITY, COMMERCIAL GRADE FOUR POST OPEN FRONT ALIGNMENT AUTO / TRUCK LIFT

This instruction manual has been prepared especially for you.
Your new lift is the product of over 40 years of continuous research, testing and development;
it is the most technically advanced lift on the market today.

READ THIS ENTIRE MANUAL BEFORE INSTALLATION & OPERATION BEGINS.

RECORD HERE THE LIFT AND
POWER UNIT INFORMATION WHICH IS LOCATED
ON THE SERIAL NUMBER DATA PLATES ON THE LIFT
AND ON THE POWER UNIT

BP BendPak		Santa Paula, CA USA www.bendpak.com
MODEL NUMBER		
DESCRIPTION		
LIFT CAPACITY	DATE OF MFG.	
ROLLING JACK MAX CAP.	MAX PSI / BAR	
VOLTAGE	SERIAL NUMBER	
<input type="checkbox"/> 110-240V, 50-60 Hz, 1 Ph <input type="checkbox"/> 208-240V, 50-60 Hz, 1 Ph <input type="checkbox"/> 380-415V, 50-60 Hz, 3 Ph <input type="checkbox"/> 208-440V, 50-60 Hz, 3 Ph		
	UIC	
DANGER! Disconnect Power Before Servicing		CE EAC <small>WARRANTY VOID IF DATA PLATE IS REMOVED PN 590863</small>

Power Unit Model # _____
 Power Unit Date Of Mfg. _____
 Power Unit Serial # _____

Maximum Operating Hydraulic Pressure 2,950 PSI

**This information is required when
calling for parts or warranty issues.**

PRODUCT WARRANTY

Our comprehensive product warranty means more than a commitment to you; it's also a commitment to the value of your new BendPak lift. For full warranty details and to register your new lift contact your nearest BendPak dealer or visit:
[http:// www.bendpak.com/support/warranty/](http://www.bendpak.com/support/warranty/)

NOTE:

Every effort has been taken to ensure complete and accurate instructions have been included in this manual, however, possible product updates, revisions and or changes may have occurred since this printing. BendPak Ranger reserves the right to change specifications without incurring any obligation for equipment previously or subsequently sold. Not responsible for typographical errors.

IMPORTANT NOTICE

Do not attempt to install this lift if you have never been trained on basic automotive lift installation procedures. Never attempt to lift components without proper lifting tools such as forklift or cranes. Stay clear of any moving parts that can fall and cause injury. These instructions must be followed to ensure proper installation and operation of your lift. Failure to comply with these instructions can result in serious bodily harm and void product warranty. Manufacturer will assume no liability for loss or damage of any kind, expressed or implied resulting from improper installation or use of this product.

PLEASE READ ENTIRE MANUAL PRIOR TO INSTALLATION.

DEFINITIONS OF HAZARD LEVELS

Identify the hazard levels used in this manual with the following definitions and signal words:



Watch for this symbol: It means immediate hazards which will result in severe personal injury or death.



Watch for this symbol: It means hazards or unsafe practices which could result in severe personal injury or death.



Watch for this symbol: It means hazards or unsafe practices which may result in minor personal injury, product or property damage.

OWNER'S RESPONSIBILITY

To maintain the lift and user safety, the responsibility of the owner is to read and follow these instructions:

- ◆ Follow all installation and operation instructions.
- ◆ Make sure installation conforms to all applicable Local, State, and Federal Codes, Rules, and Regulations; such as State and Federal OSHA Regulations and Electrical Codes.
- ◆ Carefully check the lift for correct initial function.
- ◆ Read and follow the safety instructions. Keep them readily available for machine operators.
- ◆ Make certain all operators are properly trained, know how to safely and correctly operate the unit, and are properly supervised.
- ◆ Allow unit operation only with all parts in place and operating safely.
- ◆ Carefully inspect the unit on a regular basis and perform all maintenance as required.
- ◆ Service and maintain the unit only with authorized or approved replacement parts.
- ◆ Keep all instructions permanently with the unit and all decals on the unit clean and visible.

BEFORE YOU BEGIN

Receiving:

The shipment should be thoroughly inspected as soon as it is received. The signed bill of lading is acknowledgement by the carrier of receipt in good condition of shipment covered by your invoice. If any of the goods called for on this bill of lading are shorted or damaged, do not accept them until the carrier makes a notation on the freight bill of the shorted or damaged goods. Do this for your own protection.

NOTIFY THE CARRIER AT ONCE if any hidden loss or damage is discovered after receipt and request the carrier to make an inspection. If the carrier will not do so, prepare a signed statement to the effect that you have notified the carrier (on a specific date) and that the carrier has failed to comply with your request.

IT IS DIFFICULT TO COLLECT FOR LOSS OR DAMAGE AFTER YOU HAVE GIVEN THE CARRIER A CLEAR RECEIPT. File your claim with the carrier promptly. Support your claim with copies of the bill of lading, freight bill, invoice, and photographs, if available. Our willingness to assist in helping you process your claim does not make BendPak responsible for collection of claims or replacement of lost or damaged materials.

TABLE OF CONTENTS

Warranty / Serial Number Information	2
Definitions of Hazard Levels	3
Owner's Responsibility	3
Before You Begin.	3
Installers / Operators Agreement / Protective Equipment	5
Safety / Warning Instructions	6
Step 1 / Selecting Site	7
Step 2 / Floor Requirements / Concrete Specifications	7
Assembly View / Description of Parts	8
Floor Plan / Specifications	9
Clearances	10
Power Unit Location.	11
Step 3 / Column and Cross Tube Installation.	12-13
Step 4 / Anchoring The Columns	13-14
Step 5 / Raising the Cross Tubes	14
Step 6 / Powerside Runway Installation	15
Step 7 / Offside Runway Installation	15
Step 8 / Cable Sheave Installation	17
Step 9 / Cable Installation	16-18
Step 10 / Power Unit Installation	18
Step 11 / Routing Hydraulic Hoses	19-21
Step 12 / Routing Air Lines	21-22
Step 13 / Power Unit Hook Up	23-25
Step 14 / Inspecting Slack Safety Springs	25
Step 15 / Lift Start Up / Final Adjustments	25-26
Step 16 / Attaching Approach Ramps / Tire stops.	26-27
Step 17 / Leveling/Synchronizing	27
Step 18 / Adding Grease	28
Step 19 / Bleeding	28
Optional Equipment Installation.	29-30
Step 19 / Operation Instructions	31
Step 20 / Lift Operation Safety	32-34
Wire Rope Inspection and Maintenance	35
Safe Lift Operation	38-39
Troubleshooting Guide	38-41
Lubrication Points	42
Labels	43-45
Parts Drawings.	46-53
Maintenance Logs.	54-55
Declaration of Conformity	56

**INSTALLER / OPERATOR
PLEASE READ AND FULLY
UNDERSTAND.
BY PROCEEDING YOU AGREE TO
THE FOLLOWING.**

- ◆ I have visually inspected the site where the lift is to be installed and verified the concrete to be in good condition and free of cracks or other defects. I understand that installing a lift on cracked or defective concrete could cause lift failure resulting in personal injury or death.
- ◆ I understand that a level floor is required for proper installation and level lifting.
- ◆ I understand that I am responsible if my floor is of questionable slope and that I will be responsible for all charges related to pouring a new level concrete slab if required and any charges.
- ◆ I understand that BendPak lifts are supplied with concrete fasteners meeting the criteria of the American National Standard "Automotive Lifts - Safety Requirements for Construction, Testing, and Validation" ANSI/ALI ALCTV-2011, and that I will be responsible for all charges related to any special regional structural and/or seismic anchoring requirements specified by any other agencies and/or codes such as the Uniform Building Code (UBC) and/or International Building Code (IBC).
- ◆ I assume full responsibility for the concrete floor and condition thereof, now or later, where the above equipment model(s) are to be installed. Failure to follow danger, warning, and caution instructions may lead to serious personal injury or death to operator or bystander or damage to property.
- ◆ I understand that Bendpak lifts are designed to be installed in indoor locations only. Failure to follow installation instructions may lead to serious personal injury or death to operator or bystander or damage to property or lift.



Failure to follow danger, warning, and caution instructions may lead to serious personal injury or death to operator or bystander or damage to property.



Please read entire manual prior to installation. Do not operate this machine until you read and understand all the dangers, warnings and cautions in this manual. For additional copies or further information, contact:

BendPak Inc. / Ranger Products

1645 Lemonwood Dr.
Santa Paula, CA. 93060
1-805-933-9970

www.bendpak.com

**INSTALLER / OPERATOR
PROTECTIVE EQUIPMENT**

Personal protective equipment helps makes installation and operation safer, however, it does not take the place of safe operating practices. Always wear durable work clothing during any installation and/or service activity. Shop aprons or shop coats may also be worn, however loose fitting clothing should be avoided. Tight fitting leather gloves are recommended to protect technician hands when handling parts. Sturdy leather work shoes with steel toes and oil resistant soles should be used by all service personnel to help prevent injury during typical installation and operation activities.

Eye protection is essential during installation and operation activities. Safety glasses with side shields, goggles, or face shields are acceptable. Back belts provide support during lifting activities and are also helpful in providing worker protection. Consideration should also be given to the use of hearing protection if service activity is performed in an enclosed area, or if noise levels are high.



THIS SYMBOL POINTS OUT IMPORTANT SAFETY INSTRUCTIONS WHICH IF NOT FOLLOWED COULD ENDANGER THE PERSONAL SAFETY AND/OR PROPERTY OR YOURSELF AND OTHERS AND CAN CAUSE PERSONAL INJURY OR DEATH. READ AND FOLLOW ALL INSTRUCTIONS IN THIS MANUAL BEFORE ATTEMPTING TO OPERATE THIS MACHINE.

INTRODUCTION

1. Carefully remove the crating and packing materials. **CAUTION!** Be careful when cutting steel banding material as items may become loose and fall causing personal harm or injury.

2. Check the voltage, phase and proper amperage requirements for the motor shown on the motor plate. Wiring should be performed by a certified electrician only.

IMPORTANT SAFETY INSTRUCTIONS

Read these safety instructions entirely!

IMPORTANT NOTICE

Do not attempt to install this lift if you have never been trained on basic automotive lift installation procedures.

Never attempt to lift components without proper lifting tools such as forklift or cranes.

Stay clear of any moving parts that can fall and cause injury.

1. **READ AND UNDERSTAND** all safety warning procedures before operating lift.

2. **KEEP HANDS AND FEET CLEAR.** Remove hands and feet from any moving parts. Keep feet clear of lift when lowering. Avoid pinch points.

3. **KEEP WORK AREA CLEAN.** Cluttered work areas invite injuries.

4. Consider work area environment. Do not expose equipment to rain. **DO NOT** use in damp or wet locations. Keep area well lighted.

5. **ONLY TRAINED OPERATORS** should operate this lift. All non-trained personnel should be kept away from work area. Never let non-trained personnel come in contact with, or operate lift.

6. **USE LIFT CORRECTLY.** Use lift in the proper manner. Never use lifting adapters other than what is approved by the manufacturer.

7. **DO NOT** override self-closing lift controls.

8. **REMAIN CLEAR** of lift when raising or lowering vehicle.

9. **CLEAR AREA** if vehicle is in danger of falling.

10. **ALWAYS ENSURE** that the safeties are engaged before any attempt is made to work on or near vehicle.

11. **DRESS PROPERLY.** Non-skid steel-toe footwear is recommended when operating lift.

12. **GUARD AGAINST ELECTRIC SHOCK.** This lift must be grounded while in use to protect the operator from electric shock. Never connect the green power cord wire to a live terminal. This is for ground only.



13. **DANGER!** The power unit used on this lift contains high voltage. Disconnect power at the receptacle before performing any electrical repairs. Secure plug so that it cannot be accidentally plugged in during service.



14. **WARNING! RISK OF EXPLOSION.** This equipment has internal arcing or sparking parts which should not be exposed to flammable vapors. This machine should not be located in a recessed area or below floor level.



15. **MAINTAIN WITH CARE.** Keep lift clean for better and safer performance. Follow manual for proper lubrication and maintenance instructions. Keep control handles and/or buttons dry, clean and free from grease and oil.

16. **STAY ALERT.** Watch what you are doing. Use common sense. Be aware.

17. **CHECK FOR DAMAGED PARTS.** Check for alignment of moving parts, breakage of parts or any condition that may affect its operation. Do not use lift if any component is broken or damaged.

18. **NEVER** remove safety related components from the lift. Do not use lift if safety related components are damaged or missing.

19. Keep hair, loose clothing, fingers, and all parts of body away from moving parts

20. Use only as described in this manual. Use only manufacturer's recommended attachments

21. **ALWAYS WEAR SAFETY GLASSES.** Everyday eyeglasses only have impact resistant lenses, they are not safety glasses

22. **SAVE THESE INSTRUCTIONS.**

TOOLS REQUIRED

- ◆ Rotary Hammer Drill or Similar
- ◆ 3/4" Masonry Bit
- ◆ Hammer
- ◆ 4 Foot Level
- ◆ Open-End Wrench Set: SAE/Metric
- ◆ Socket And Ratchet Set: SAE/Metric
- ◆ Hex-Key / Allen Wrench Set
- ◆ Large Crescent Wrench
- ◆ Large Pipe Wrench
- ◆ Crow Bar
- ◆ Chalk Line
- ◆ Medium Flat Screwdriver
- ◆ Tape Measure: 25 Foot Minimum
- ◆ Needle Nose Pliers

NOTE:

An air supply (30 PSI Min / 3 CFM Min) will be required for the safety-lock mechanisms. See page 19, Step 11.

IMPORTANT NOTICE

These instructions must be followed to ensure proper installation and operation of your lift. Failure to comply with these instructions can result in serious bodily harm and void product warranty. Manufacturer will assume no liability for loss or damage of any kind, expressed or implied resulting from improper installation or use of this product.

PLEASE READ ENTIRE MANUAL PRIOR TO INSTALLATION

STEP 1

(Selecting Site)

Before installing your new lift, check the following.

1. **LIFT LOCATION:** Always use architects plans when available. Check layout dimension against floor plan requirements making sure that adequate space is available.
2. **OVERHEAD OBSTRUCTIONS:** The area where the lift will be located should be free of overhead obstructions such as heaters, building supports, electrical lines etc.
3. **DEFECTIVE FLOOR:** Visually inspect the site where the lift is to be installed and check for cracked or defective concrete.



4. Lift is designed for **INDOOR INSTALLATION ONLY**. *Outdoor use is prohibited.* Always follow warnings illustrated on equipment labels.

STEP 2

(Floor Requirements)



This lift must be installed on a solid level concrete floor.

A level floor is suggested for proper use and installation and level lifting. If a floor is of questionable slope, consider a survey of the site and/or the possibility of pouring a new level concrete slab.



- ◆ DO NOT install or use this lift on any asphalt surface or any surface other than concrete.
- ◆ DO NOT install or use this lift on expansion seams or on cracked or defective concrete.
- ◆ DO NOT install or use this lift on a second / elevated floor without first consulting a building architect.
- ◆ Refer to ANSI/ALI ALIS Standard (R2015) *Safety Requirements for Installation and Service* for more information about safely installing your Lift.

CONCRETE SPECIFICATIONS

LIFT MODEL	CONCRETE REQUIREMENTS
HDSO-14P	4.25" Min. Thickness / 3,000 PSI
HDSO-14AX	4.25" Min. Thickness / 3,000 PSI



All models **MUST** be installed on 3,000 PSI concrete only conforming to the minimum requirements shown above. New concrete must be adequately cured by at least 28 days minimum.

IMPORTANT NOTE:

BendPak lifts are supplied with installation instructions and concrete fasteners meeting the criteria as prescribed by the American National Standard "Automotive Lifts - Safety Requirements for Construction, Testing, and Validation" ANSI/ALI ALCTV-2011. Lift buyers are responsible for any special regional structural and/or seismic anchoring requirements specified by any other agencies and/or codes such as the Uniform Building Code (UBC) and/or International Building Code (IBC).

! DANGER

When removing the lift from shipping angles pay close attention as the runways can slide and can cause injury. Prior to removing the bolts make sure the runways are held securely by a fork lift or some other heavy lifting device.

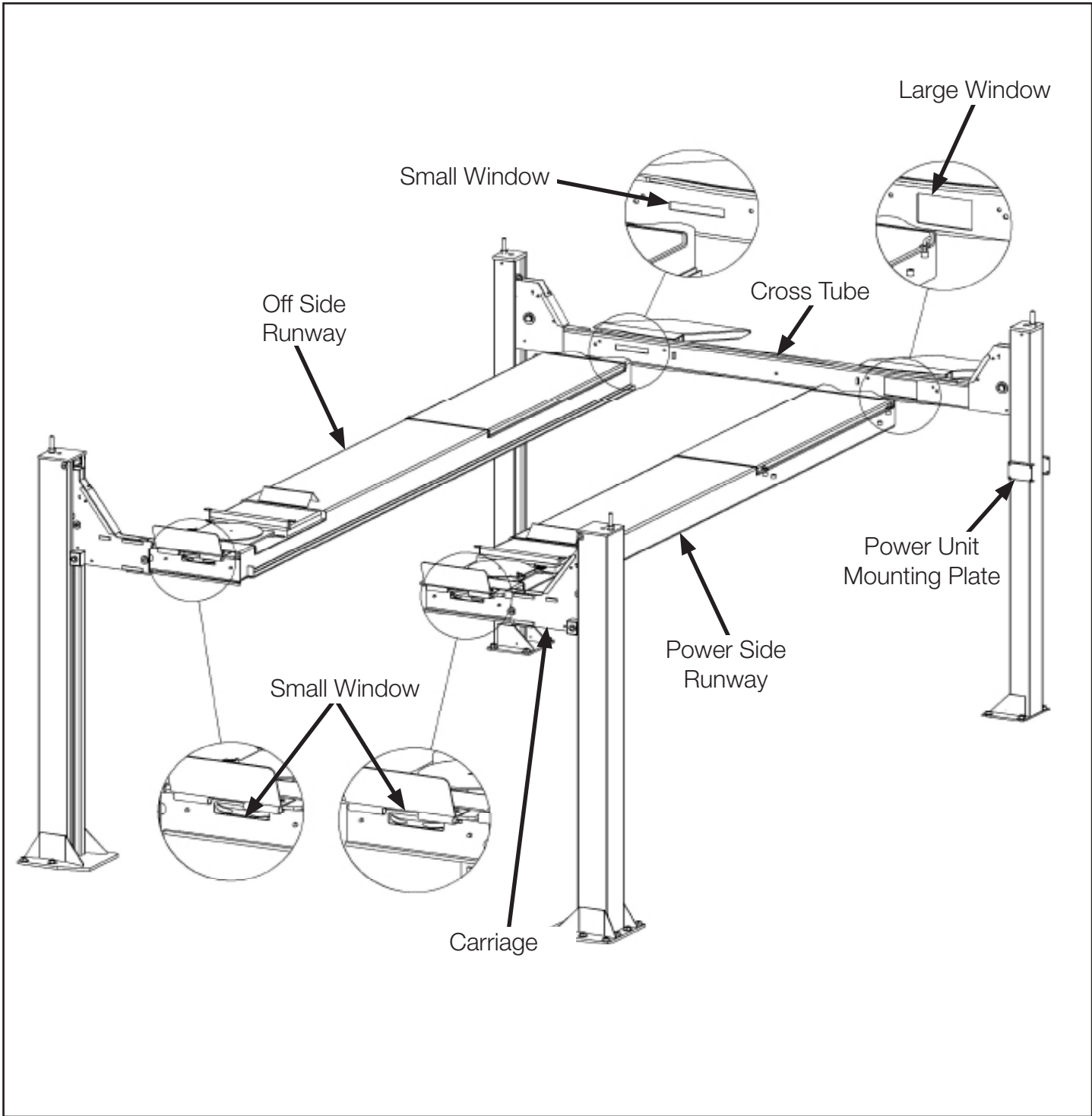

IMPORTANT NOTE:

The power unit must be installed as shown above. It is important to locate the POWER-SIDE runway (with cylinder) on the SAME SIDE as the power unit. Rolling Jack / Utility rails on the side of each runway MUST be installed to the inside.

FLOOR PLAN

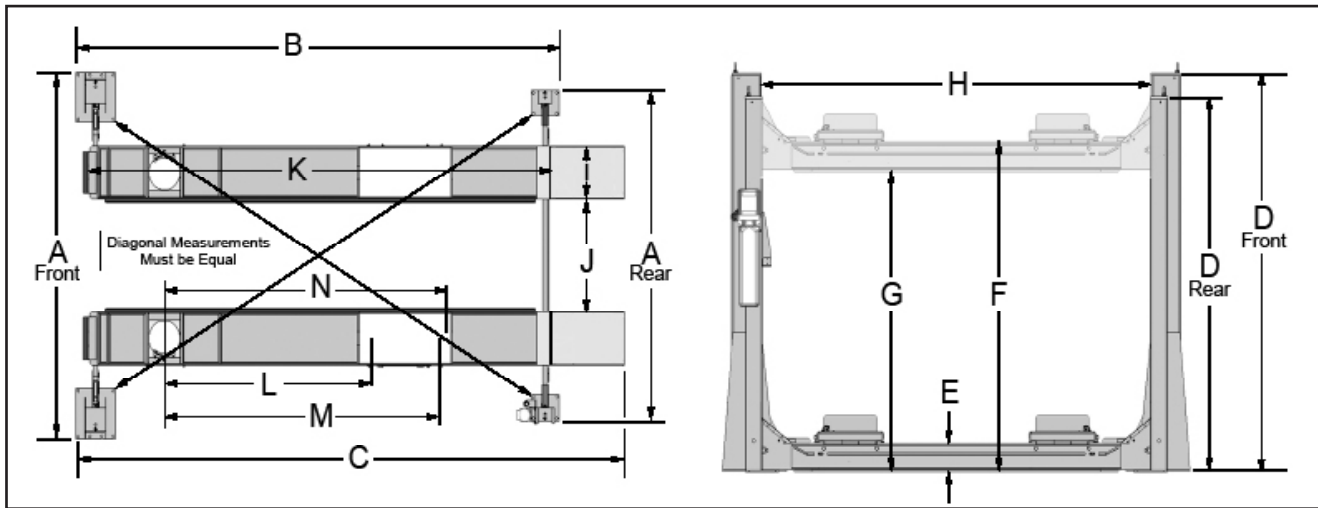

* IMPORTANT NOTE *

Check diagonal measurements to confirm square layout; diagonal measurements must be equal.

Model	HDSO-14P	HDSO-14AX
Lifting Capacity	14,000 lbs / 6350 kg	14,000 lbs / 6350 kg
A - Overall Width / Front	143" / 3638 mm	143" / 3638 mm
A - Overall Width / Rear	130" / 3304 mm	130" / 3304 mm
B - Outside Length	215 1/2" / 5472 mm	215 1/2" / 5472 mm
C - Overall Length	244" / 6195 mm	244" / 6191 mm
D - Height of Columns / Front	103" / 2623 mm	103" / 2623 mm
D - Height of Columns / Rear	92" / 2338 mm	92" / 2338 mm
E - Min. Runway Height	7-5/8" / 192 mm	7-5/8" / 192 mm
F - Max. Rise	70" / 1778 mm	70" / 1778 mm
G - Max Lifting Height	77 1/2" / 1970 mm	77 1/2" / 1970 mm
H - Width Between Columns / Front	113" / 2800 mm	113" / 2800 mm
H - Width Between Columns / Rear	110" / 2796 mm	110" / 2796 mm
I - Runway Width	20" / 508 mm	20" / 520 mm
J - Width Between Runways(*)	45" / 1146 mm	45" / 1146 mm
K - Length of Runways	199" / 5054 mm	199" / 5054 mm
L - Min. 4- Wheel Alignment (**)	72" / 1828 mm	89" / 2261 mm
M - Max 4 Wheel Alignment (**)	135" / 3428 mm	156" / 3962 mm
N - Max 2 Wheel Alignment (**)	174" / 4420 mm	182" / 4623 mm
Min. Wheelbase @ Rated Capacity	140" / 3556 mm	140" / 3556 mm
Min. Wheelbase 75% Rated Capacity	120" / 3048 mm	120" / 3048 mm
Min. Wheelbase 50% Rated Capacity	100" / 2540 mm	100" / 2540 mm
Min. Wheelbase 75% Rated Capacity	80" / 2032 mm	80" / 2032 mm
Locking Positions	13	13
Lock Spacing	Every 4" / 102 mm	Every 4" / 102 mm
Lifting Time	60 Seconds	60 Seconds
Standard Motor	220 VAC / 60Hz 1 Ph.	220 VAC / 60Hz 1 Ph.

Emission sound pressure at Operator Position < 70 dB(A)

* This dimension may be limited with the addition of rolling jacks. See Rolling Jack Specifications on Separate page.

** For CE compliant countries see errata sheet included with control panel.

The design, material and specifications are subject to change without notice.

CLEARANCES

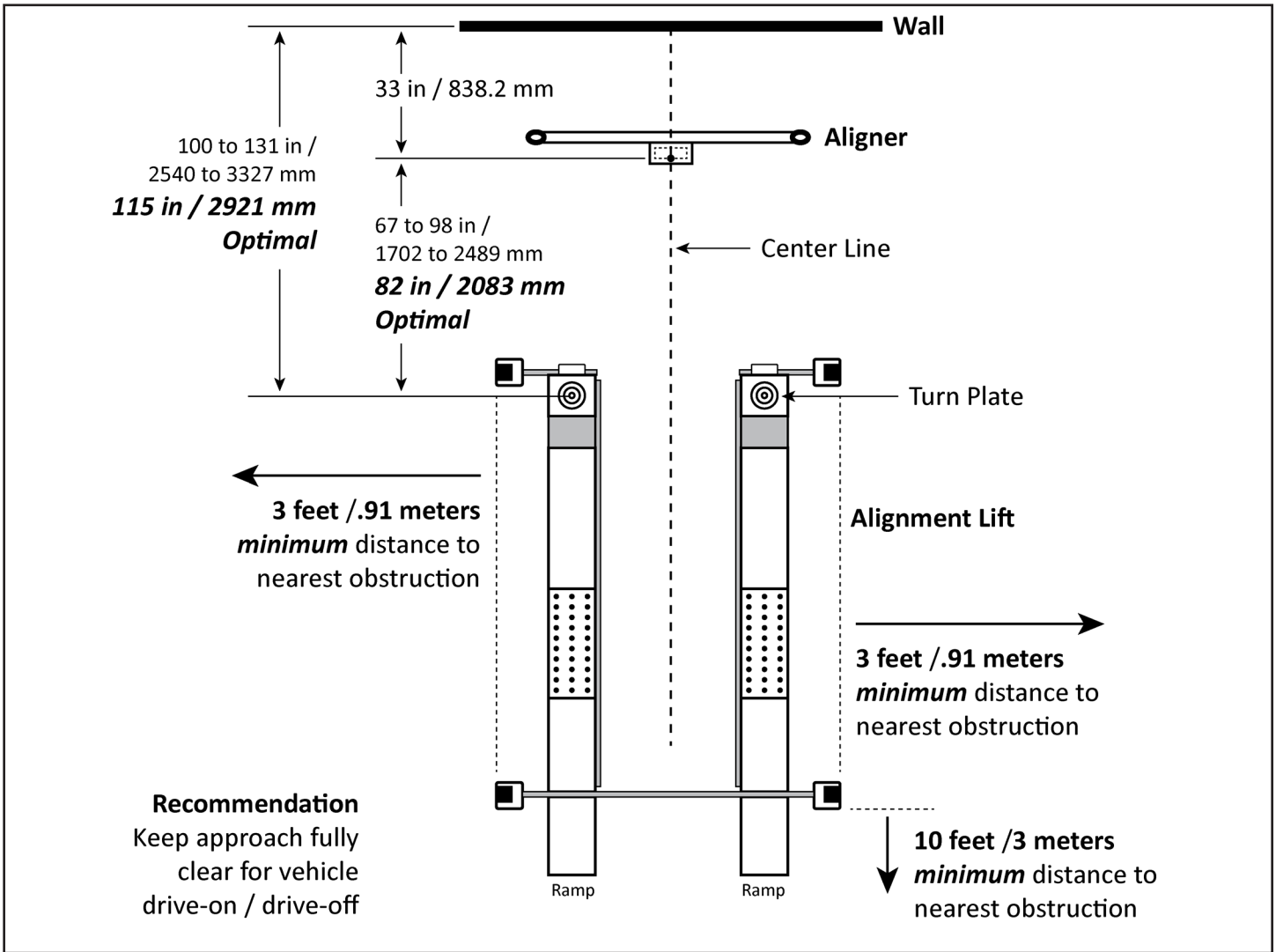

1. Lift Location: Use architects plan and Engineers automatic level (transit) when available to locate lift. The above shows clearances of a typical bay layout. Lift floor area should be level.

2. Ceiling or overhead clearance must be 80" plus height of tallest vehicle.

3. Estimating Column Shim requirements:
In the following section, the terms "highest" and "lowest" refer to elevation of floor.

a. Mark locations where lift columns will be positioned in bay.

b. Place target on floor at column positions (NOT on column base plates) and record readings.

c. Find the highest of the four locations. Find the difference between the readings at each of the remaining three columns and the highest reading.

d. The difference is the estimated amount of shim thickness needed at each column.

Note: Maximum shim thickness is 1/2" per column using shims and anchors provided with lift.

If no transit is available, floor slope can be determined by using a chalk line and level.

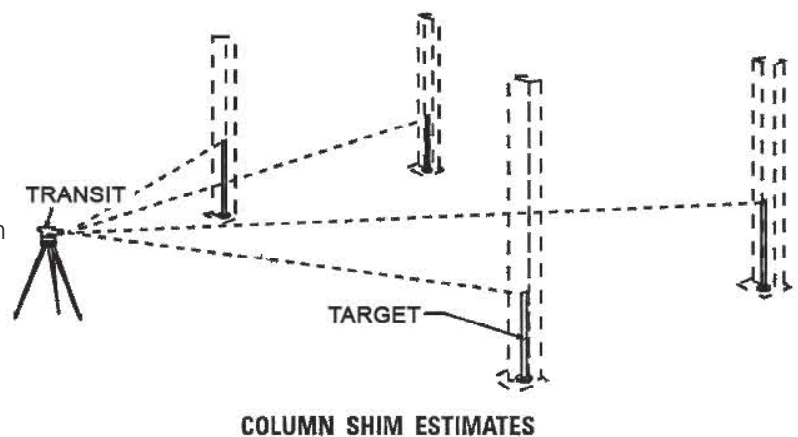

POWER UNIT LOCATION

The power unit will be located at "X" location shown below. It is important to locate the POWER SIDE runway (with cylinder) on the SAME SIDE as the power unit location.
Note the location of the bulkhead fitting holes in the POWER SIDE runway.
Utility rails on the side of each runway MUST be installed to the inside.

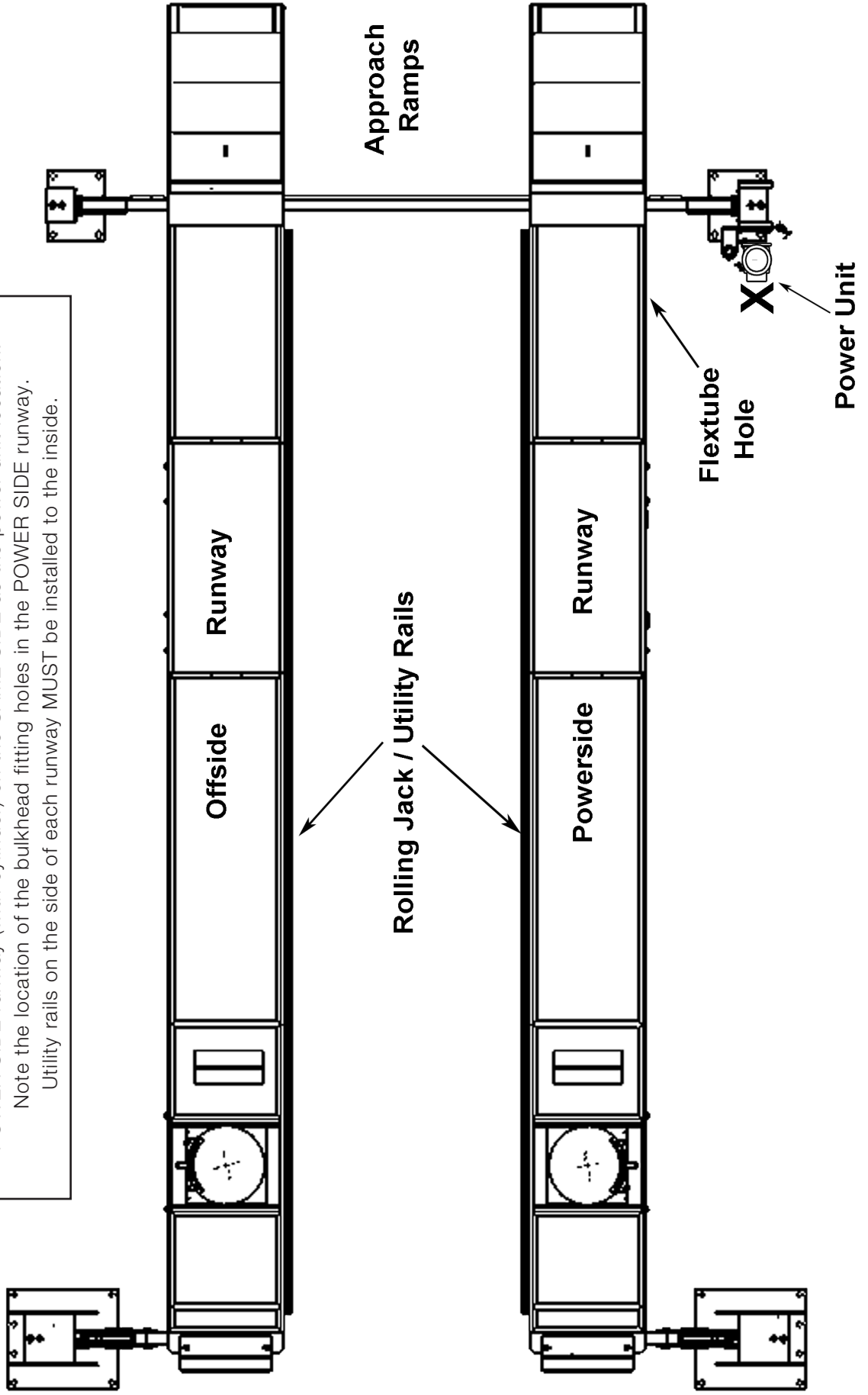

STEP 3

(Column & Cross Tube Installation)

1. Place a chalk line on the floor according to the floor plan layout. Pay attention to the Power Unit location. Locate and stand the Columns at their respective locations. **DO NOT BOLT** columns down at this time. Use caution to prevent the Columns from falling over. (See Fig. 3.1)

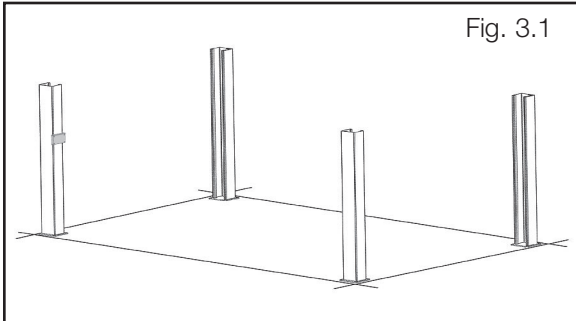

2. To estimate the shim requirements, place a target on floor at each Column position and record the readings. Find the highest of the four locations then find the difference between each of the remaining Columns. This difference is the estimated amount of shim thickness that will be required at each Column. (See Fig. 3.2)

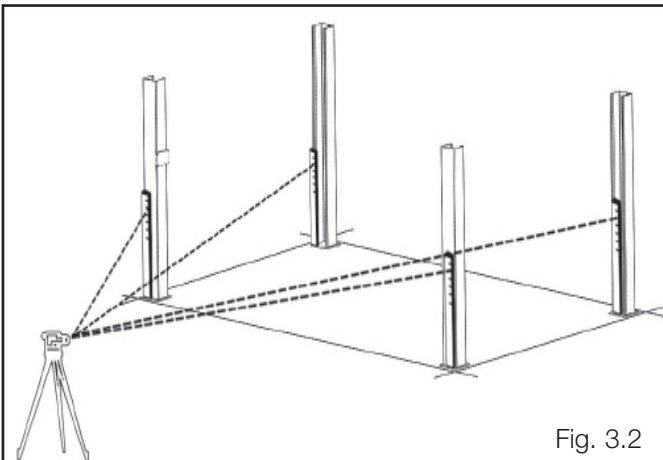

Note: The maximum shim thickness recommended by the factory is no more than 1/2" per Column using shims and anchors provided with the lift. A maximum shim thickness of 2" is possible by ordering optional shim plates. Contact your authorized BendPak Distributor for ordering information.

3. Using a forklift or crane, raise the Cross tubes (making sure the Plastic Slide Blocks and Buttons are still in position) and drop down into the top of the Columns. NOTE: The Large Sheave Window should be positioned inward and adjacent the Power Unit Column. (See Fig. 3.3)



ENSURE THAT THE FRONT POST UPPER AND LOWER SLIDE BLOCKS AND BUTTON SLIDES ARE IN POSITION AS SHOWN BEFORE PROCEEDING.

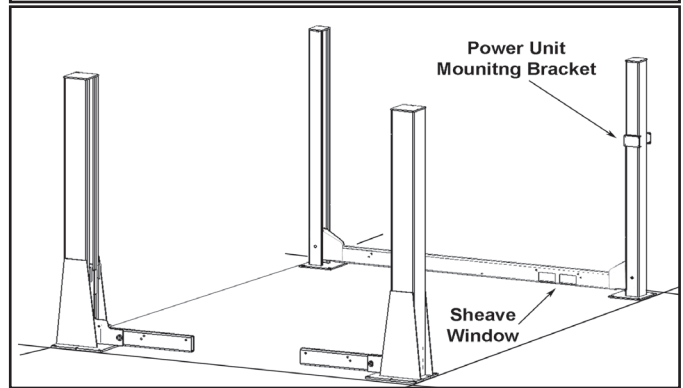
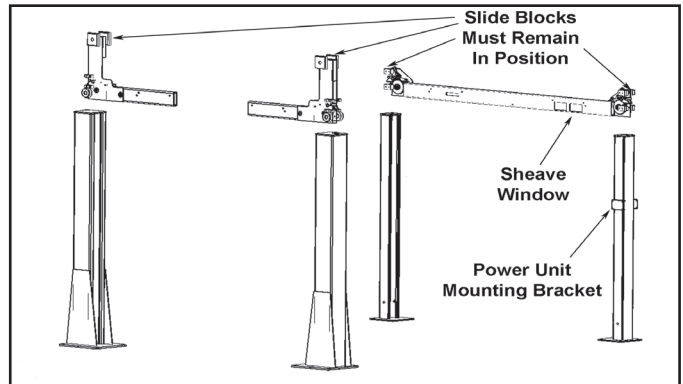
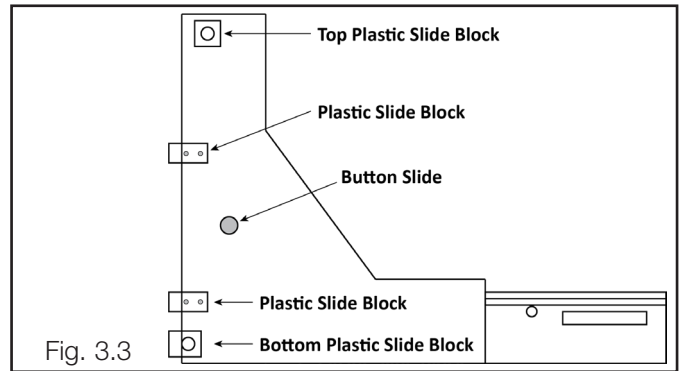

4. With the Columns standing and the cross tubes in position, install the Safety Ladders. Pass the ladders through the Column openings and drop down through the Slide Block guide slots on the Cross Tube until the Ladders come to rest on the Base Plates. **DO NOT BOLT** Columns down at this time. (See Fig. 3.4 - 3.5)

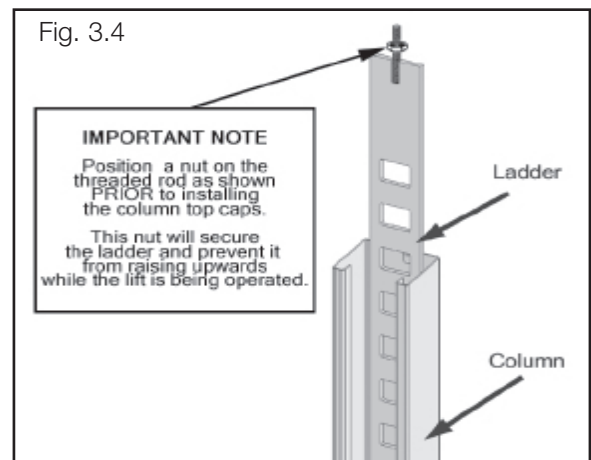

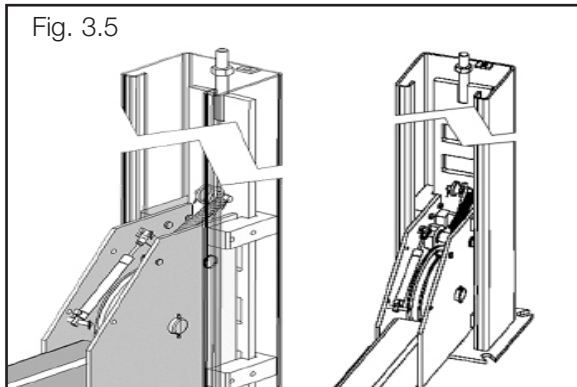

Fig. 3.5

5. The Columns and Cross Tubes will now be in position and spaced properly for the Runways.

6. Install the Column TOP CAPS using the M10 X 1.50 X 50 hex bolts, nuts & washers. Install the nut on each Safety Ladder until 1/2" of threads are exposed and the ladder is raised at least 1/2" off of the base of the Column.

NOTE: Raise the ladder at least 1/2" off of the base of the column or damage to the lift will occur. Be sure to position the cable hole INWARD. (See Fig. 3.6 -3.7)

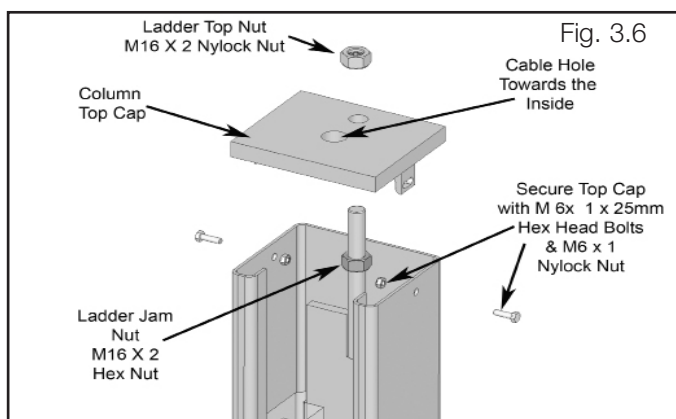

Fig. 3.6

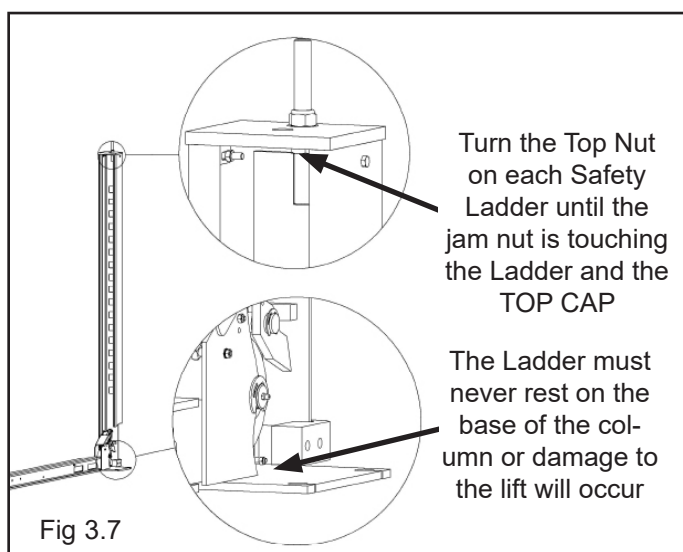

Fig 3.7

STEP 4

(Anchoring The Columns)

IMPORTANT NOTE:

BendPak lifts are supplied with installation instructions and concrete fasteners meeting the criteria as prescribed by the American National Standard "Automotive Lifts - Safety Requirements for Construction, Testing, and Validation" ANSI/ALI ALCTV-2011. Lift buyers are responsible for any special regional structural and/or seismic anchoring requirements specified by any other agencies and/or codes such as the Uniform Building Code (UBC) and/or International Building Code (IBC).

1. Before proceeding, double check the measurements and make certain that the Bases of each Column are square and aligned with the chalk line. (See Fig. 4.1)

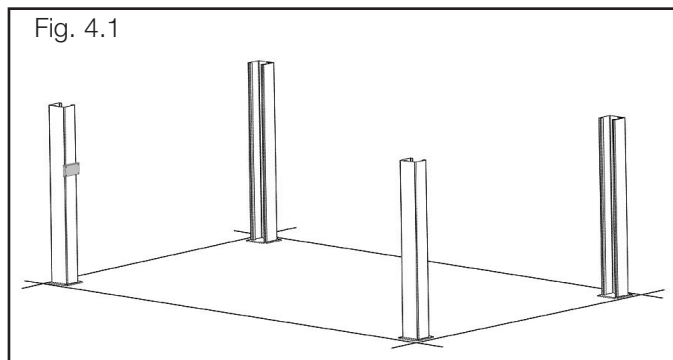

Fig. 4.1



ALWAYS WEAR SAFETY GOGGLES

2. Using the Base Plate on each Column as a guide, drill each anchor hole approximately 4-1/2" deep using a rotary hammer drill and 3/4" concrete bit.. (See Fig. 4.2)

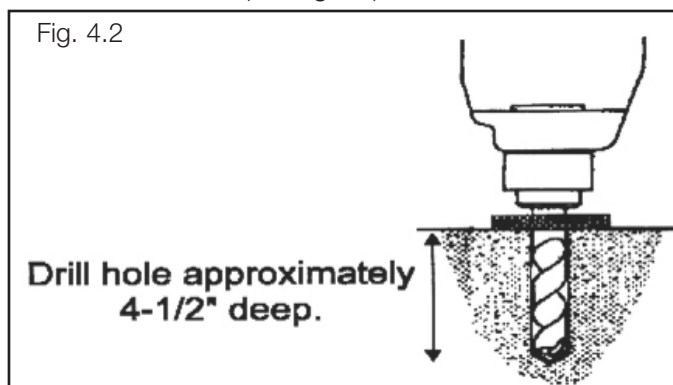

Fig. 4.2

3. After drilling, remove dust thoroughly from each hole using compressed air and/or bristle brush. Make certain that the Columns remain aligned with the chalk line.

4. Assemble the Washers and Nuts on the Anchors then tap into each hole with a hammer until the Washer rests against the Base Plate. Be sure that if shimming is required, enough threads are left exposed. (See Fig. 4.3)

Fig. 4.3

Tap anchor bolts into each hole with a hammer until the washer rests against the baseplate

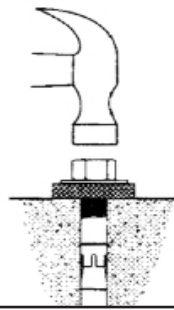

5. If shimming is required, insert the Shims as necessary under the Base Plate so that when the Anchor bolts are tightened, the Columns will be plumb. (See Fig. 4.4)

Fig. 4.4

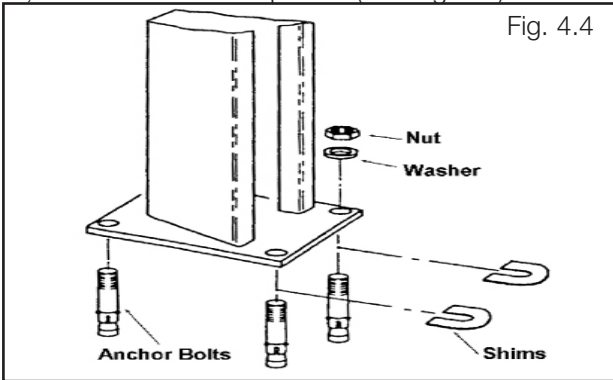

6. After any necessary Shims are installed, tighten each anchor nut three to five turns past finger tight. (See Fig. 4.5)

Tighten Nut
3-5 Turns.
Do Not Use
Impact Wrench!

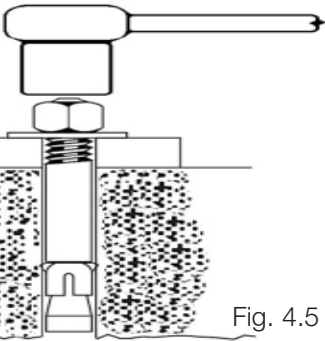

Fig. 4.5

IMPORTANT - If Anchor Bolts do not hold when torqued to required amount, concrete must be replaced. Saw cut and remove 24" x 24" square area under each Column base then re-pour with reinforced 2500 PSI concrete to a depth of six inches minimum, keying new concrete under existing floor.

STEP 5

(Raising The Cross Tubes)

1. Before proceeding it will be necessary to first raise the Cross Tubes off the ground to facilitate Cable routing and final assembly.



ENSURE THAT THE FRONT POST UPPER AND LOWER SLIDE BLOCKS ARE ORIENTED AS SHOWN IN FIGURE 3.3 ON PAGE 12. BEFORE PROCEEDING.

2. Manually raise the Cross Tubes until the primary Safety Locks engage and rest on the lock position second down from the top of the ladder or approximately 66" off the ground. It is important that the SLACK SAFETY LOCK IS CLEARED. The Slack Safety Lock must never rest on the Safety Ladder. (See Fig. 5.1)

IMPORTANT NOTE

It is important that the SLACK SAFETY LOCK IS CLEARED. The slack safety lock must never rest on the safety ladder.

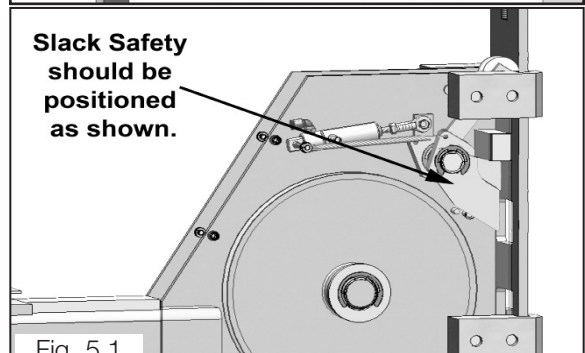
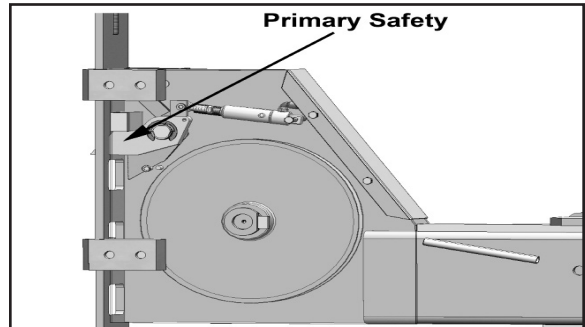
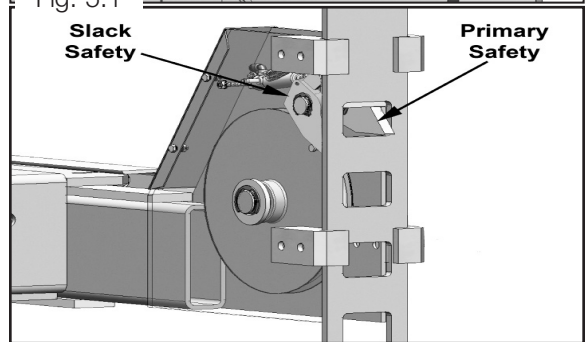
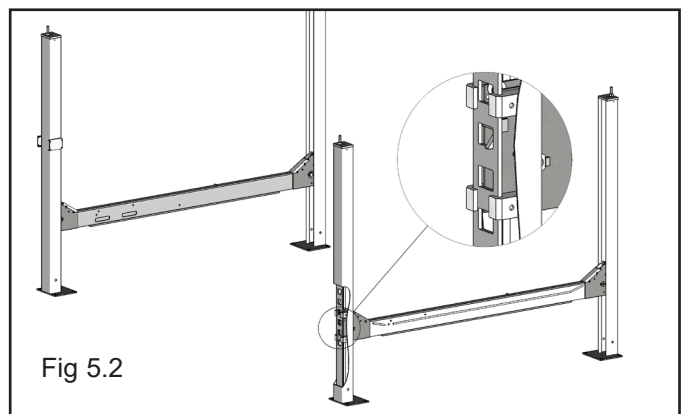

Fig. 5.1



3. The Columns and Cross Tubes will now be in position and spaced properly for the Runways. (See Fig. 5.2)



STEP 6

(Powerside Runway Installation)

1. Locate the Powerside Runway easily identified by the Cylinder and Sheave Roller mounting structures welded on the underside. The Powerside Runway will be positioned on the side of the lift where the Power Unit is installed.

(See Fig. 6.1)

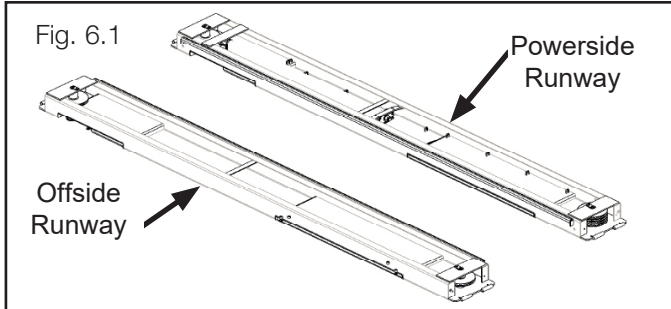

2. . Remove any pre-installed Cable Sheaves from the Powerside runway making sure to pay attention to the order in which they are removed.



ENSURE THAT THE FRONT POST UPPER AND LOWER SLIDE BLOCKS ARE ORIENTED AS SHOWN IN FIGURE 3.3 ON PAGE 12. BEFORE PROCEEDING.

3. Position the Powerside Runway on top of the Cross Tubes with the utility rail towards the center. The fitting holes located at the side of the Powerside Runway should be adjacent to the Power Unit Column.

4. Align the holes in the Runway with the holes on the Cross Tubes and bolt it into place using four M12 x 7.75 x 90 Hex Head Bolts and Washers. (See Fig. 6.2)

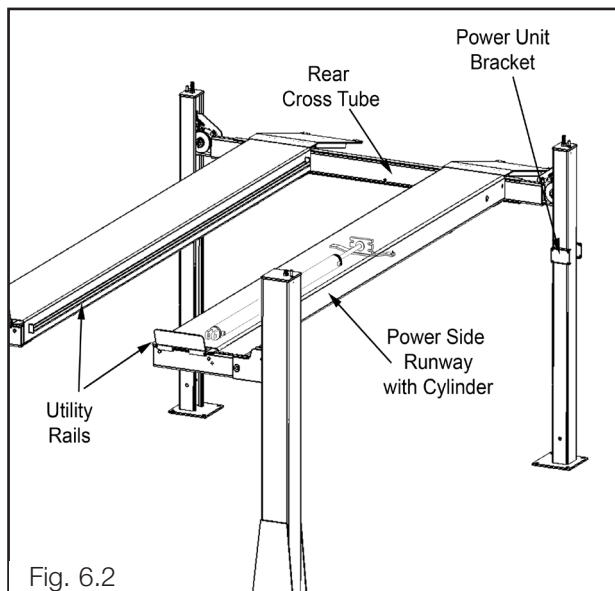

STEP 7

(Offside Runway Installation)

1. Position the Offside Runway on top of the Cross Tubes with the utility rail located inside. (See Fig. 7.1)

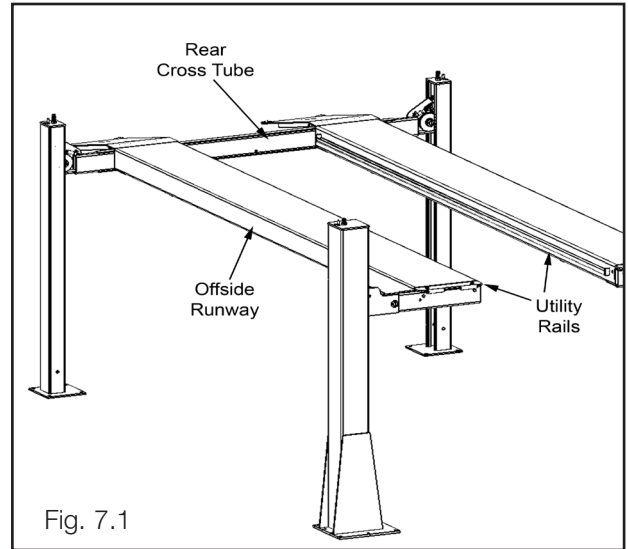

DO NOT PROCEED with cable installation or go near the lift work area unless visual confirmation is made of ALL safety locks. ALL locks MUST be engaged before proceeding. Failure to comply with these instructions may result in severe personal injury or death. (See page 14.)

HDSO-14P/14AX CABLE ROUTING

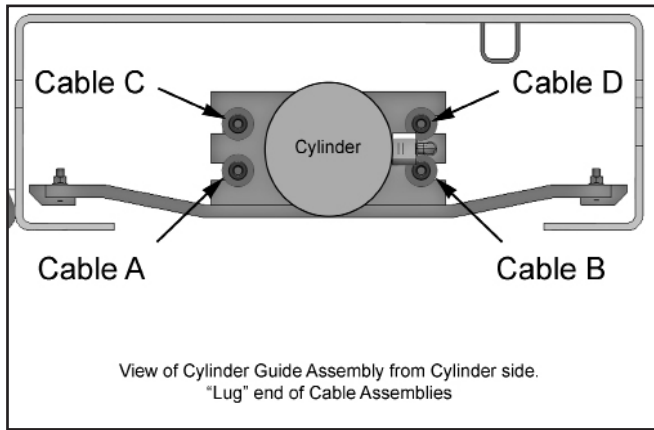
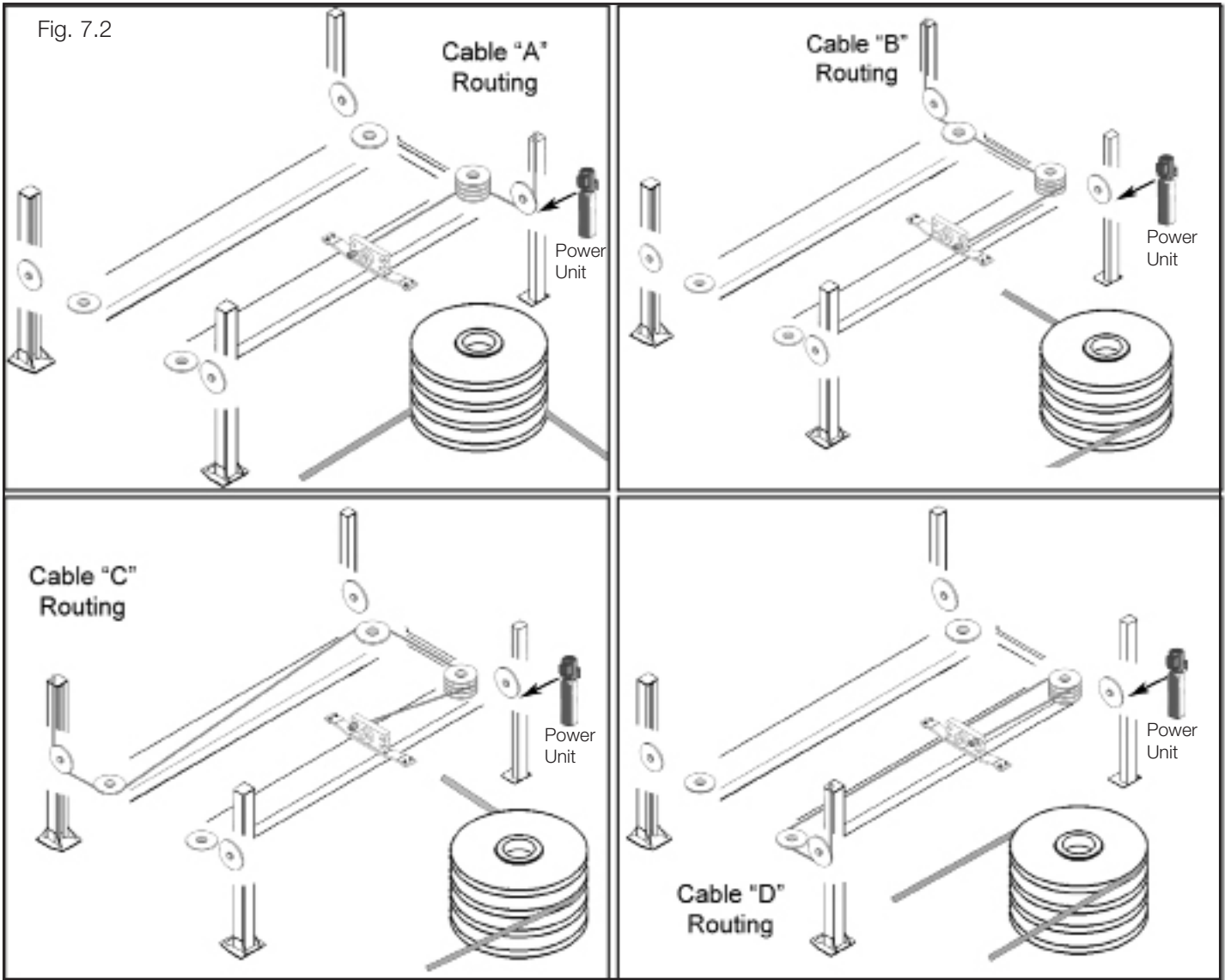

IMPORTANT

Spacers on the single sheaves are sized specifically for their location; they are different heights from the spacers at the other locations.

If you remove a sheave pin, sheave, and the spacers at any location, replace them at the same location in the exact same orientation.

	Model	Part #	Description
A	HDSO-14P/14AX	5595065	HDSO-14P/14AX/14LSXE, HDS-14X CABLE ASSEMBLY Ø12 x 4,100 mm ST
B	HDSO-14P/14AX	5595066	HDSO-14P/14AX/14LSXE, HDS-14X CABLE ASSEMBLY Ø12 x 5,732 mm ST
C	HDSO-14P/14AX	5595089	HDSO-14P/14AX CABLE ASSEMBLY Ø12 x 11,302 mm ST
D	HDSO-14P/14AX	5595931	HDSO-14P/14AX CABLE ASSEMBLY Ø12 x 9,639 mm ST

STEP 8

(Cable / Sheave Installation)



DO NOT PROCEED unless visual confirmation is made of ALL safety locks. ALL locks MUST be engaged before proceeding. Failure to comply with these instructions may result in severe personal injury or death. (See page 14)

1. Inspect Cables to ensure proper lengths. All Cables should have ID tags showing proper Cable lengths.

2. In order to install the Cables it is necessary to first extend the Hydraulic Cylinder. Remove both Cylinder port plugs then use an air gun or come-along to extend the Cylinder.

IMPORTANT! - Be careful not to damage the chrome rod during this step. (See Fig. 8.1)

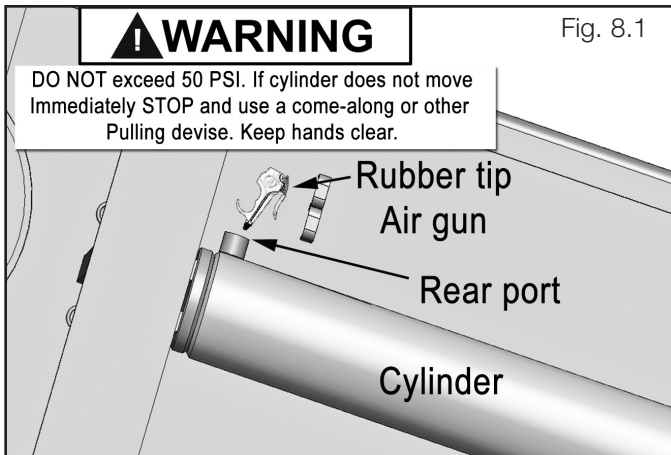

3. Loosely route the Cables around the Sheaves, (refer to the diagram on page 16), and then install the Sheave Pin and screw in the Sheave Pin Retaining Screw. (It may be or necessary to loosen the Sheave Pin and move or adjust the pulleys during cable installation.) (See Fig. 8.2)

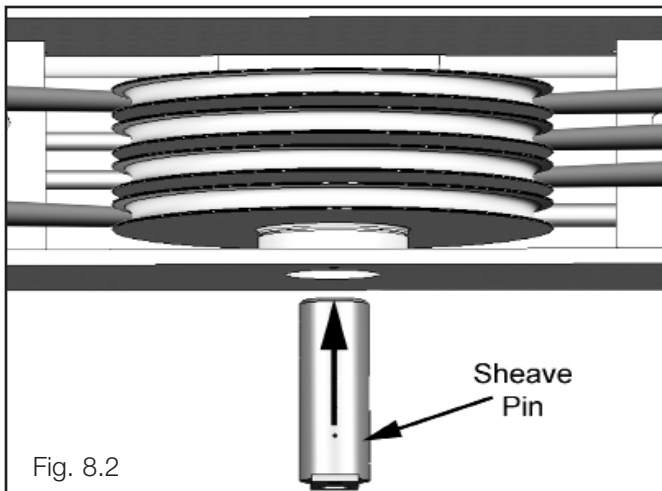

STEP 9

(Cable Installation)



Failure to route lifting cables as described may lead to serious personal injury and/or death to operator or bystander and/or may cause damage to property.



WHEN THE CABLE ADJUSTING NUTS BOTTOM OUT ON THE THREADED END OF THE CABLE CONNECTOR AND THERE IS STILL SLACK IN THE CABLES, THE CABLES HAVE STRETCHED BEYOND THE SAFE USEFUL LENGTH AND NEED TO BE REPLACED WITH FACTORY APPROVED CABLE ASSEMBLIES. DO NOT PLACE WASHERS, SPACERS OR OTHER DEVICES TO "SHORTEN" THE EFFECTIVE CABLE LENGTH AS DAMAGE TO THE LIFT OR INJURY TO PERSONS MAY OCCUR.

1. Make sure the Cylinder Flange Plate is installed with the guide assembly facing down and the Cylinder retainer plate on the outside of the guide. Lug ends of cables start at Cylinder. (See Fig. 9.1)

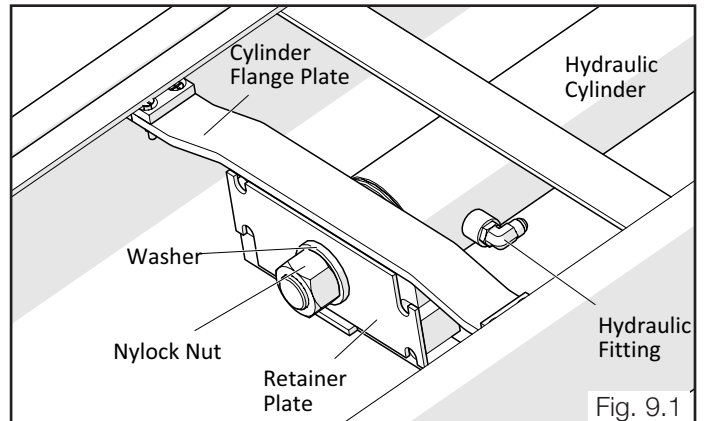

2. Route the threaded Cable ends through the ends of each Cross Tube, over the Slack Safety Sheave then to the top of each Column. Secure using the M22 Hex Head Nuts and Flat Washers. Tighten each nut until there is at least one inch of threads protruding through the top of the Nut. The Cables will remain loose until start up and final Cable adjustments are made. (See Fig. 9.2 - 9.3)

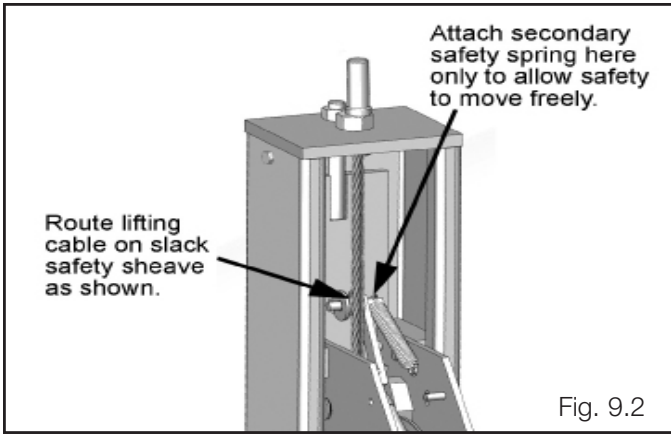

Fig. 9.2

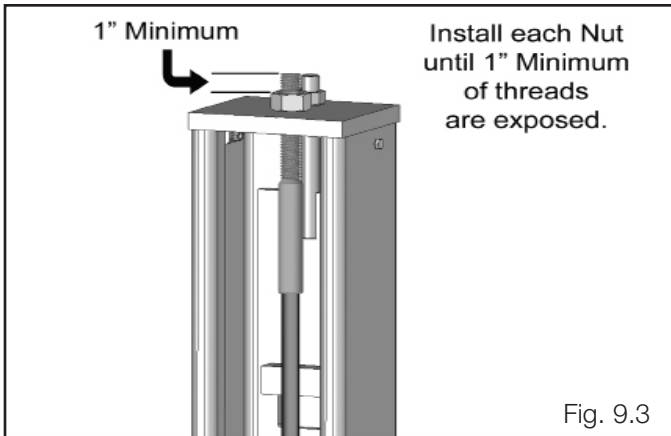

Fig. 9.3

3. After routing the Cables double-check to make sure all are properly positioned and remain within the grooves of ALL Sheaves. (See Fig. 9.4 - 9.5)

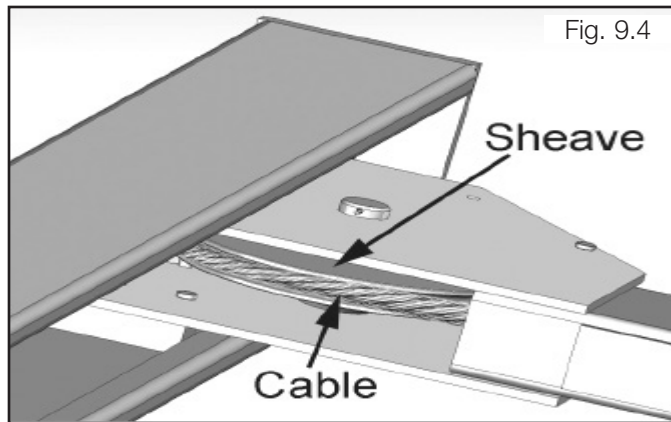

Fig. 9.4

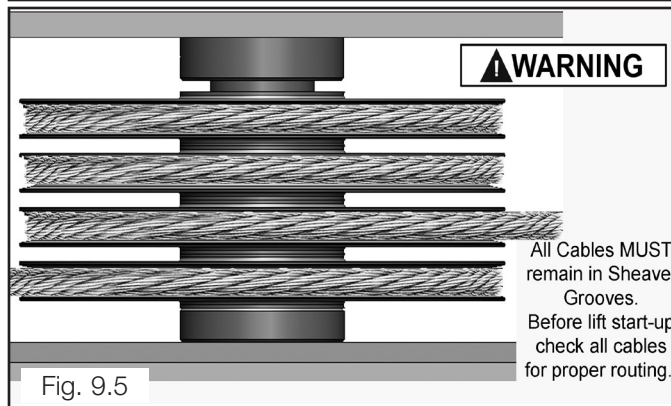

Fig. 9.5

STEP 10

(Power Unit Installation)

1. Mount the Power Unit, Air Valve Mounting Bracket, Vibration Dampner, and Flex Tube Mounting Bracket to the Power Unit Mounting Bracket using the M8 hex bolts and Nylock Nuts. Fill the reservoir with 12 quarts of 10-WT hydraulic oil or Dexron automatic transmission fluid. (See Fig. 10.1)

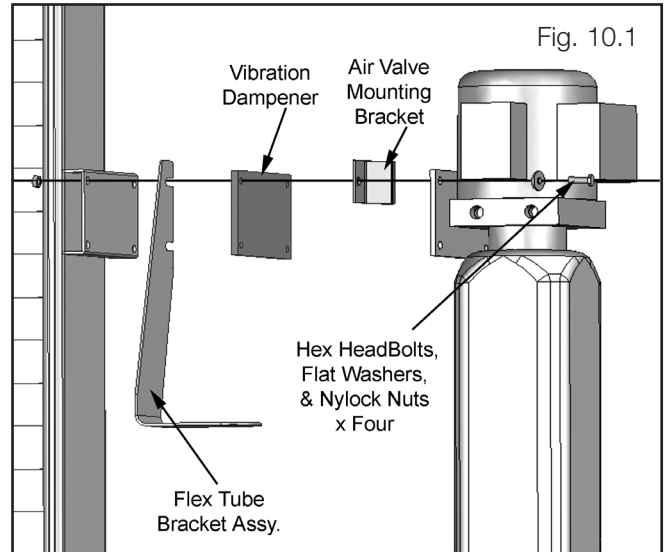

Fig. 10.1



ALL WIRING MUST BE PERFORMED BY A LICENSED ELECTRICIAN.



DO NOT PERFORM ANY MAINTENANCE OR INSTALLATION OF ANY COMPONENTS WITH OUT FIRST ENSURING THAT ELECTRICAL POWER HAS BEEN DISCONNECTED AT THE SOURCE OR PANEL AND CANNOT BE RE-ENERGIZED UNTIL ALL MAINTENANCE AND/OR INSTALLATION PROCEDURES ARE COMPLETED.

The standard Power Unit for your lift is 220 volt, 60HZ, single phase. All wiring must be performed by a certified electrician only.

PROPER WIRING INSTRUCTIONS ARE AFFIXED TO MOTOR.



DO NOT run Power Unit with no oil. Damage to pump can occur.
The Power Unit must be kept dry. Damage to Power Unit caused by water or other liquids such as detergents, acid etc., is not covered under warranty.
Operate lift only between temperatures of 41 ° - 104° F.

Improper electrical hook-up can damage motor and will not be covered under warranty.
Motor can not run on 50HZ without a physical change in motor.
Use a separate breaker for each Power Unit.
Protect each circuit with time delay fuse or circuit breaker.
For 208-230 volt, single phase, use a 25 amp fuse.
For 208-230 volt, three phase, use a 20 amp fuse.
For 380-440 volt, three phase, use a 15 amp fuse.

STEP 11

(Routing Hydraulic Hoses)

1. Install the 90-degree Hydraulic Fitting to the POWER PORT and the 90° Air Line Compression Fitting to the RETURN PORT of the Power Unit and connect the Hoses as described below. It will be necessary to remove the shipping plugs from both ports prior to installing the Fittings. (See Fig. 11.1 - 11.2)

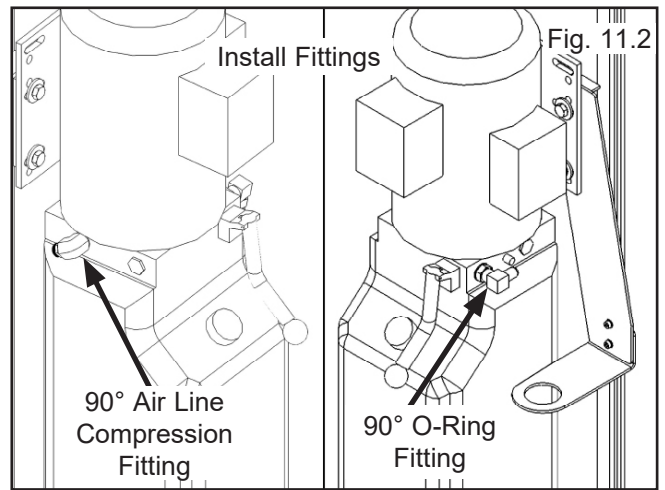
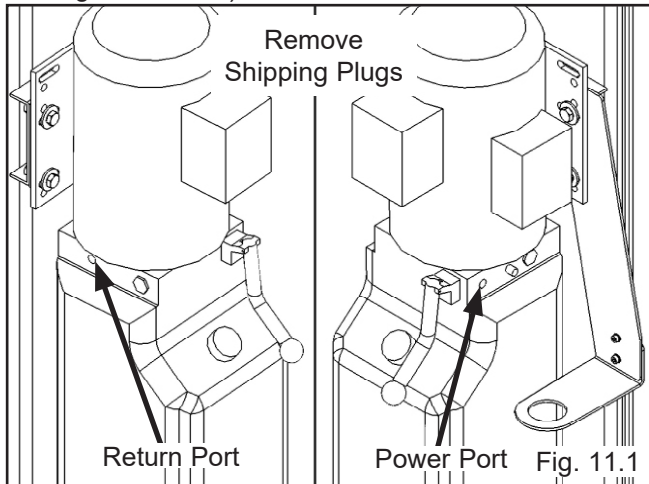

NOTE: Return Port may be on the same side as the Power Port on some models.

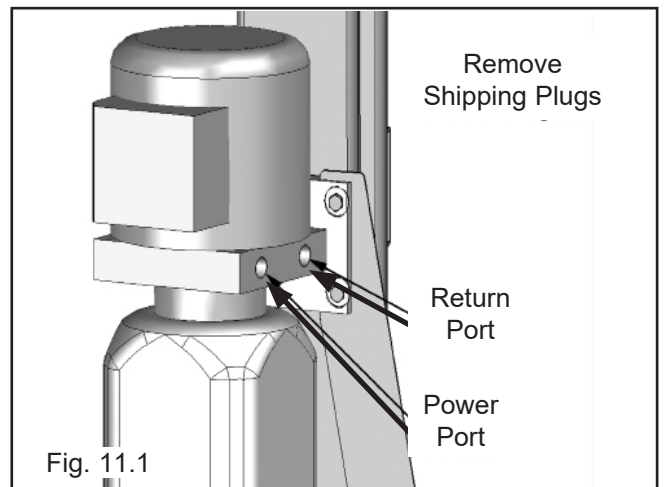

NOTE:

Check the Power Unit to determine proper connection ports for Power and Return lines. It will be necessary to remove shipping plugs from both ports prior to installing Fittings.

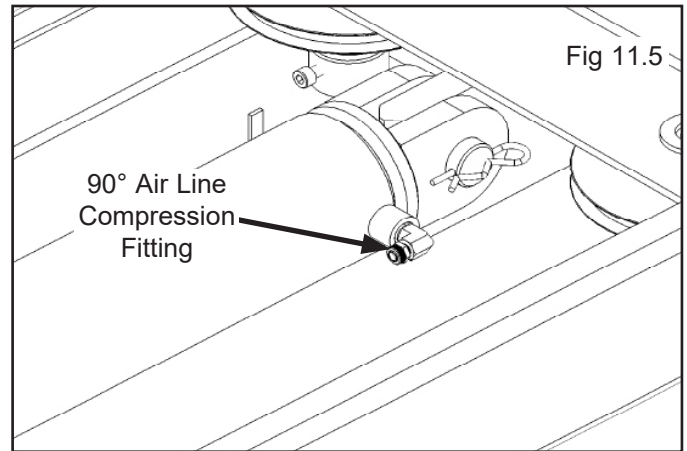
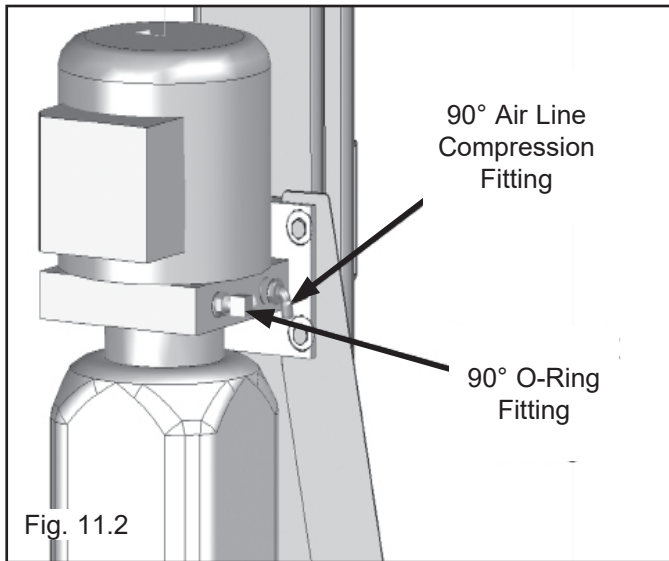

5. Route both the Power Unit Hydraulic Hose and TWO (2) lengths of Air Line through the Flex Hose. (See Fig. 11.6)

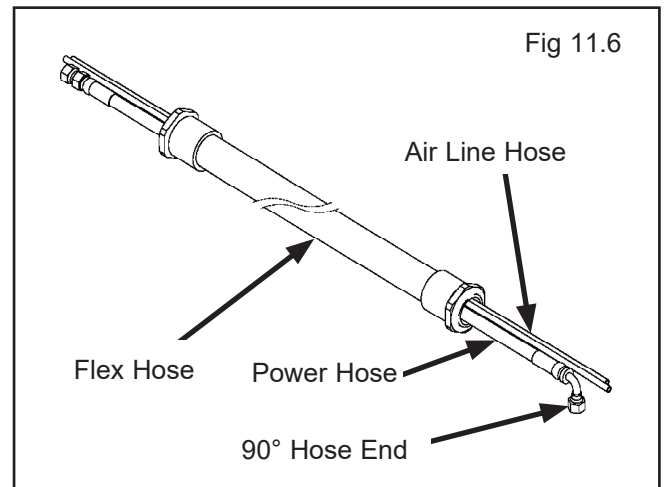

6. Install the end of Flex Hose with the Straight Fitting on the Hydraulic Hose into the hole in the Powerside Runway adjacent to the Power Unit. Install the end of the Flex Hose with the 90° Fitting on the Hydraulic Hose in the Flex Hose Bracket Assy. Tighten the plastic nuts securely. (See Fig 11.7)

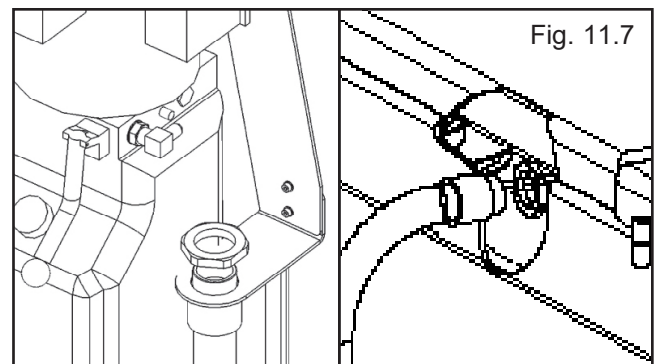

2. Remove the captive nut on the Compression Fitting. Insert the Plastic Air line through the alignment sleeve and into the end of the fitting until it bottoms out. Then tighten the nut on the fitting. (See Fig 11.3)

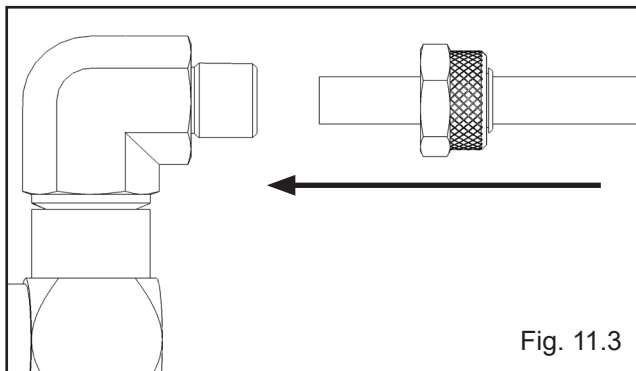

3. Install the 90-degree Hydraulic Fitting in the port at the ram end of the Cylinder. On the pipe thread side of the Fitting it is recommended to use Teflon Tape or pipe sealer. DO NOT USE TEFLON TAPE on the JIC flared end. (See Fig. 11.4)

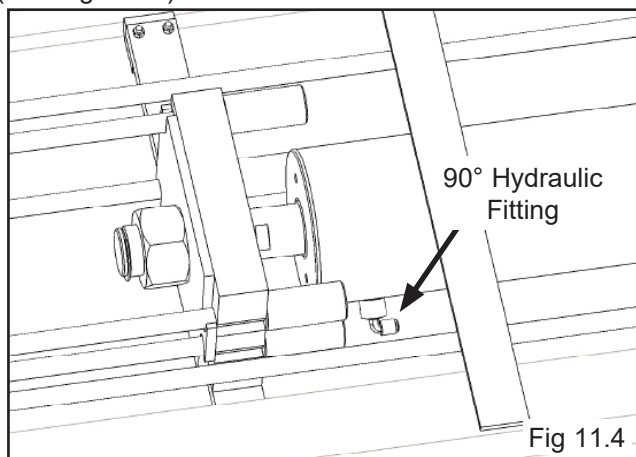

4. Install the 90-degree Air Line Compression Fitting in the port at the base, pinned end of the Cylinder. On the pipe thread side of the Fitting, it is recommended to use Teflon Tape or pipe sealer. (See Fig. 11.5)

7. Connect the hydraulic hose and air line as shown below making sure the hydraulic hose passes through the retaining rings. **MAKE SURE HOSES ARE KEPT CLEAR OF CABLES.** There will be one air line hose left unconnected in this step. This air line will be used to activate the pneumatic safety locks in the next step. See page 19 for Compression Fitting instructions. (See Fig. 11.8)

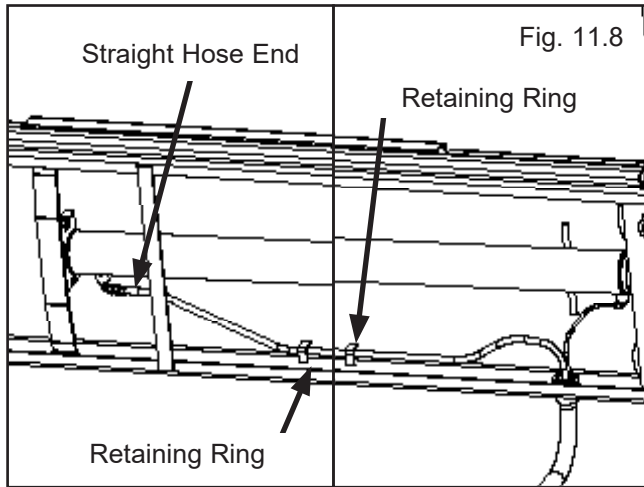

8. Connect the straight end of the Power Unit Hydraulic Line to the 90° Power Unit Fitting. Connect the Return Air Line to the 90° Air Fitting. There will be one air line hose left unconnected at this time. This air line hose will be used to activate the pneumatic safety locks on the next page.

(See Fig. 11.9)

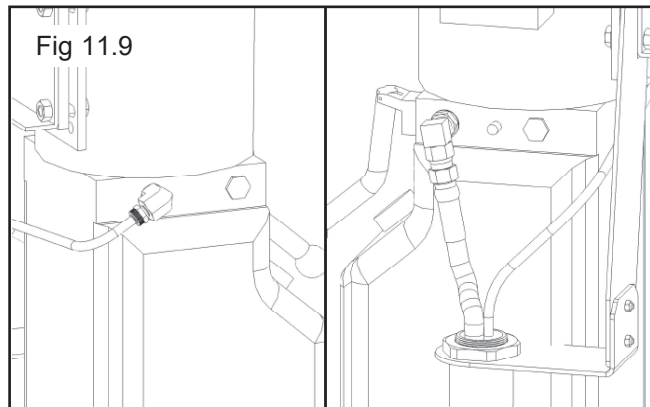

STEP 12 (Routing Air Lines)

1. Mount the Push Button Air Valve Assembly on to the power unit mounting bracket. The Push Button Air Valve should be positioned away from the Power Side Ramp on the “out” side of the lift for operator safety. (See Fig 12.1)

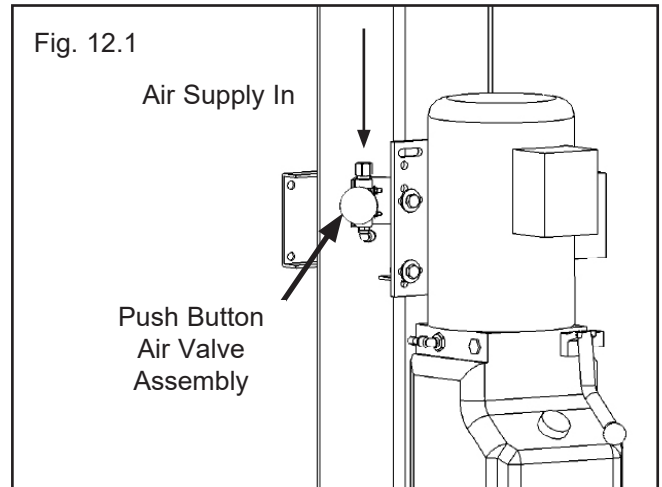

2. Route the air line that was left unconnected in Step 10 to the 90° Air Line Compression Fitting of the Push Button Air Valve Assembly. (See Fig 12.2)

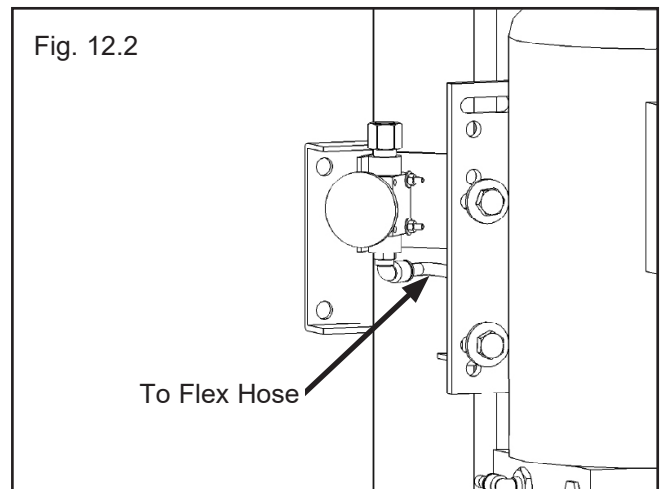

3. Once the air line has been connected with the Push Button Air Valve, cut the air lines to length by following the Safety Air Line Routing diagram located on Page 22 and connect female branch “tee” fittings where needed.

NOTE:

MAKE SURE THE PUSH BUTTON AIR VALVE PORT MARKED “INLET” IS FACING TOWARDS THE SOURCE OF COMPRESSED AIR.

NOTE:

A FILTER/REGULATOR/LUBRICATOR MUST BE INSTALLED ON AIR SUPPLY AT LIFT. FAILURE TO DO SO WILL VOID THE WARRANTY.

SAFETY AIR LINE ROUTING

NOTE:

CUT THE PROVIDED 1/4" AIR LINE TUBING WITH A SHARP BLADE TO LENGTHS AS REQUIRED. TUBING MUST BE CUT SQUARE WITH ALL PLASTIC BURRS REMOVED.

AIR TUBING ASSEMBLY:

SEE PAGE 19 FOR ASSEMBLY OF AIR LINE TUBING INTO FITTING.

CAUTION:

REMOVING THE AIR TUBING FROM THE COMPRESSION FITTINGS WILL CAUSE DAMAGE TO THE TUBING ITSELF. USE OF A DAMAGED AIR LINE MAY RESULT IN SAFETY LOCK FAILURE.

AIRLINE ROUTING

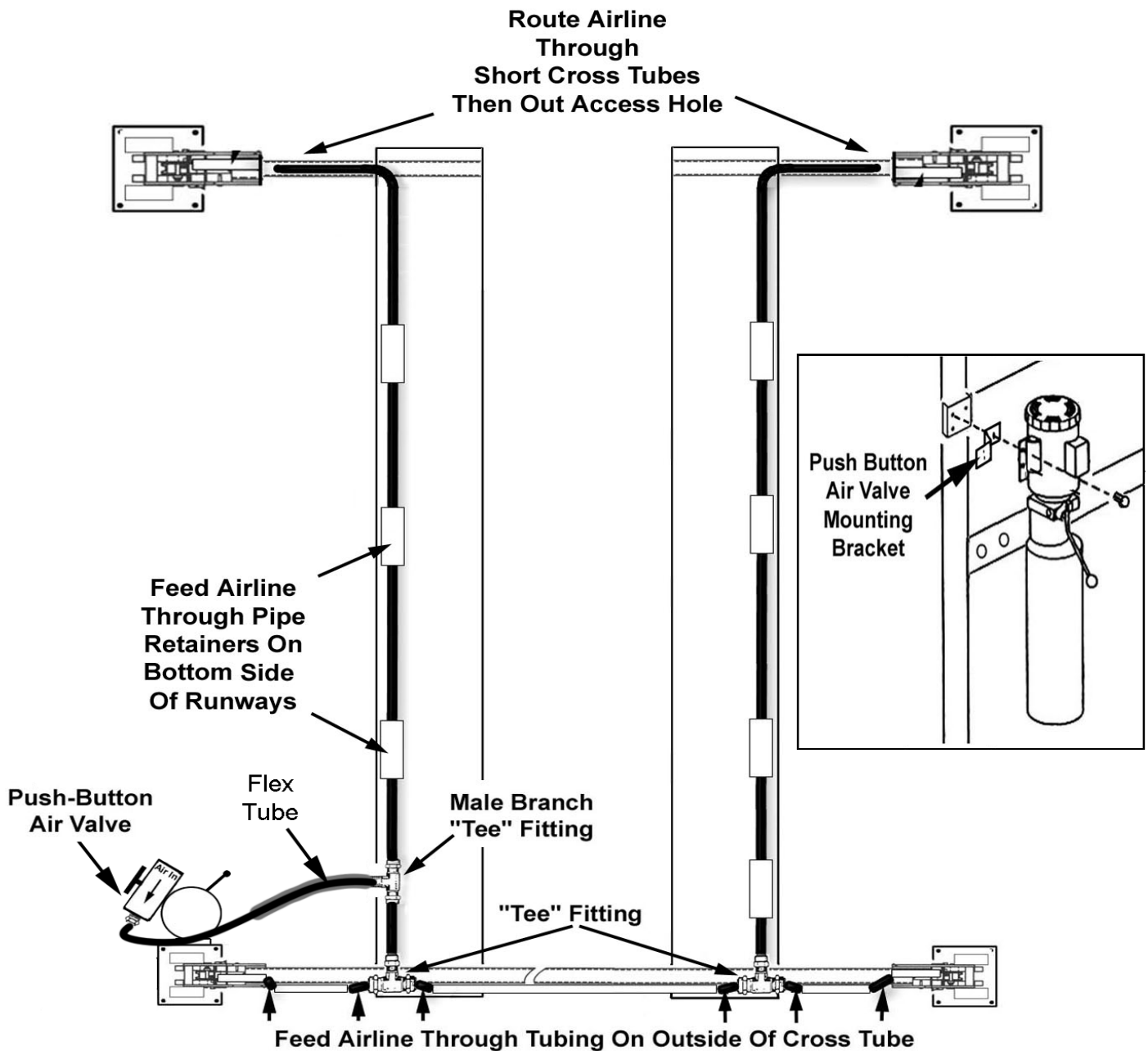



DO NOT PERFORM ANY MAINTENANCE OR INSTALLATION OF ANY COMPONENTS WITHOUT FIRST ENSURING THAT ELECTRICAL POWER HAS BEEN DISCONNECTED AT THE SOURCE OR PANEL AND CANNOT BE RE-ENERGIZED UNTIL ALL MAINTENANCE AND/OR INSTALLATION PROCEDURES ARE COMPLETED.



IMPORTANT POWER-UNIT INSTALLATION NOTES

- DO NOT run power unit with no oil. Damage to pump can occur.
- The power unit must be kept dry. Damage to power unit caused by water or other liquids such as detergents, acid etc., is not covered under warranty.
- Improper electrical hook-up can damage motor and will not be covered under warranty.
- Motor can not run on 50HZ without a physical change in motor.
- Use a separate breaker for each power unit.
- Protect each circuit with time delay fuse or circuit breaker.
- For 208-230 volt, single phase, use a 25 amp fuse.
- For 208-230 volt, three phase, use a 20 amp fuse.
- For 380-440 volt, three phase, use a 15 amp fuse.

Installation and adjustment.

DO NOT attempt to raise vehicle until a thorough operation check has been completed.

ALL WIRING MUST BE PERFORMED BY A CERTIFIED ELECTRICIAN ONLY.

Identify which Power Unit the lift was shipped with by looking on the data tag affixed to the Power Unit motor head. If the model number begins with the letter "S" then use the "S" wiring diagrams. If the model number begins with the letter "E" or "F" then use the "E" or "F" wiring diagrams.

PROPER WIRING INSTRUCTIONS ARE AFFIXED TO THE MOTOR.

"S" MODEL

Single Phase 220V

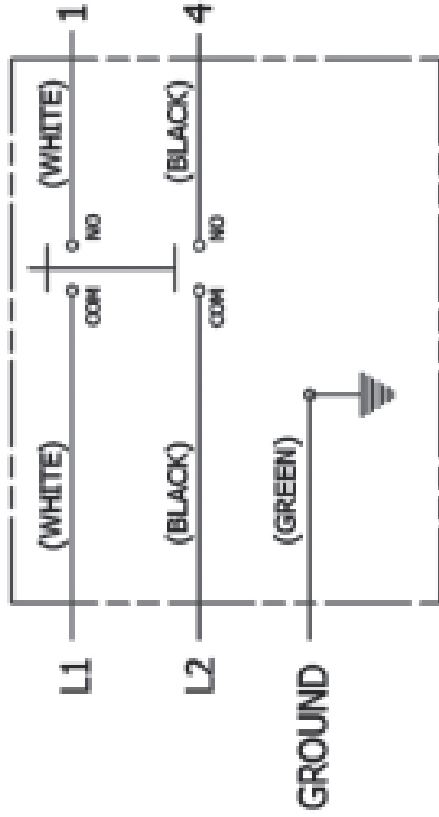

"S" MODEL

Three Phase 220V

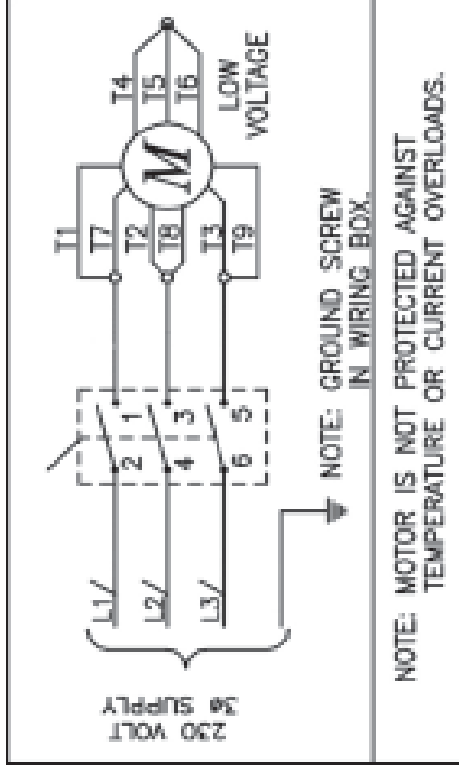

"E" or "F" MODEL

Single Phase 220V

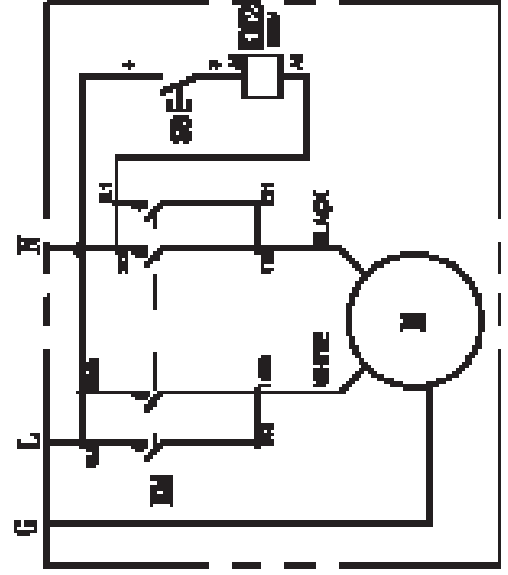

STEP 13

(Power Unit Hook Up)

1. Have a certified electrician run the Power Supply to motor. Refer to the data plate found on the motor for proper power supply and wire size.



RISK OF EXPLOSION

This equipment has internal arcing or parts that may spark and should not be exposed to flammable vapors. Motor should not be located in a recessed area or below floor level.

NEVER expose motor to rain or other damp environments. **DAMAGE TO MOTOR CAUSED BY WATER IS NOT COVERED UNDER WARRANTY.**

IMPORTANT NOTE:

CAUTION Never operate the motor on line voltage less than 208V. Motor damage may occur which is not covered under warranty. Have a certified electrician run appropriate power supply to motor. Size wire for 25 amp circuit. See Motor Operating Data Table.

IMPORTANT: Use separate circuit for each power unit.

Protect each circuit with time delay fuse or circuit breaker. For single phase 208-230V, use 25 amp fuse.

Three phase 208-240V, use 25 amp fuse. For three phase 400V and above, use 15 amp fuse. All wiring must comply with NEC and all local electrical codes.

Fig. 13.1

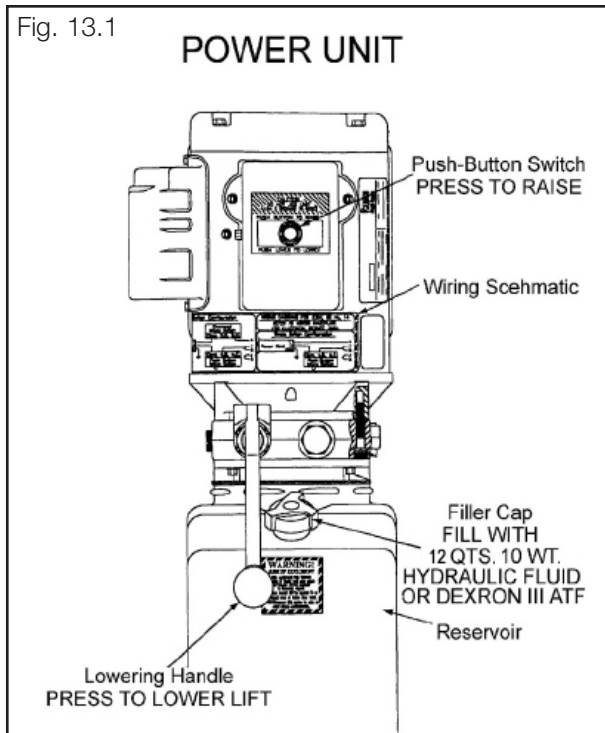

STEP 14

(Inspecting The Slack Safety Springs)



The following steps involve the SLACK CABLE SAFETY DEVICE and MAIN SAFETY. Failure to follow these steps could result in serious injury or death in the event of cable failure.

1. Inspect the ends of the ALL SAFETY LOCK SPRINGS as shown. Make sure the spring ends are secure at both ends. **DO NOT ATTEMPT TO RAISE THE LIFT UNTIL THE SLACK SAFETY SPRINGS ARE ATTACHED AND THE ROLLERS ARE PULLED CLEAR FROM THE LADDER.** (See Fig. 14.1)

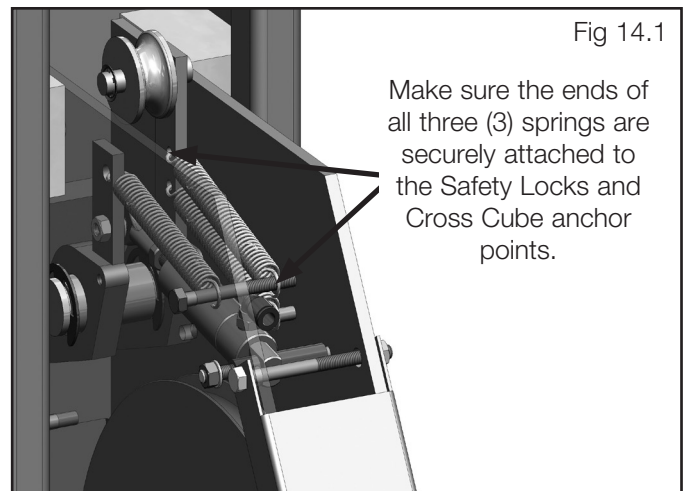

2. Repeat this step for each corner of the lift.

STEP 15

(Lift Start Up / Final Adjustments)

1. Make sure the Power Unit reservoir is full with 12 quarts of 10-WT hydraulic oil or Dexron-III automatic transmission fluid.
2. Spray the inside of the Columns where the Slide Blocks glide with a light lubricant or WD-40.
3. Test the Power Unit by pressing the push-button switch. If the motor sounds like it is operating properly, raise the lift and check all Hose Connections for leaks. If the motor gets hot or sounds peculiar, stop and check all electrical connections.
4. Before proceeding, double-check to make sure all Cables are properly positioned within the grooves of ALL Sheaves. Make sure all Cable Sheave retaining pins and/or clips are secure.

5. Check to make sure that all Slack Safety Locks are cleared and free. (See Fig. 15.1)

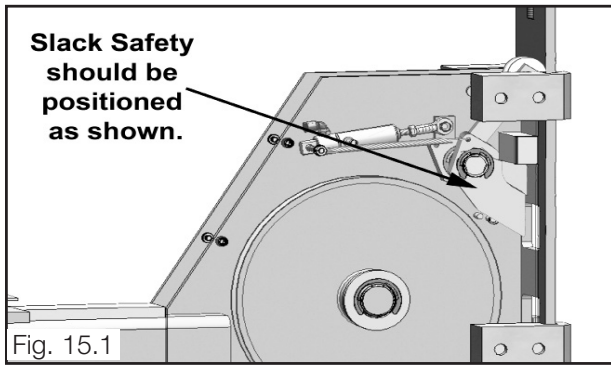

6. Continue pressing the raise button until the Cables get taugted and the lift starts to move.

7. Raise lift until the lift stops and lower until the Safeties engage the Top Locking Position. Adjust each ladder so that each Safety Lock rests on the corresponding Top Lock Position. Then adjust each Cable Nut so that each Safety Lock is ONE INCH (1") above the Top Lock Position. The Cable Nuts **MUST** be tightened until there is at least one inch of threads protruding through the nut. (See Fig. 15.2) Failure to do so could result in serious injury or death.

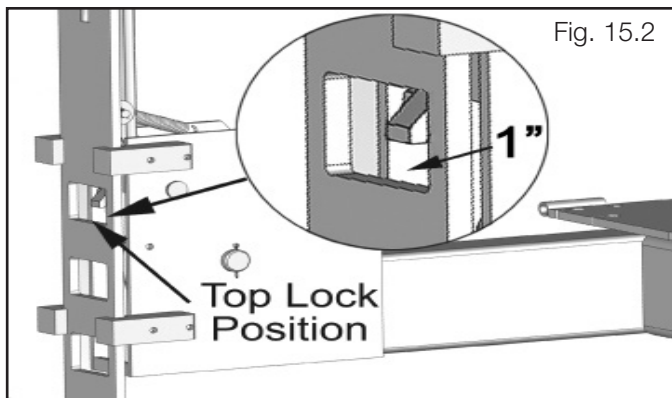

⚠ WARNING

All Cable Nuts **MUST** be tightened on each end until there is at least one inch of threads protruding through the nut. Failure to do so could result in serious injury or death.

NOTE:

There will be initial stretching of the cables in the beginning and/or with increased loads. Adjust the cables as outlined above a week after first use, then every three to six months thereafter depending on usage and/or to compensate for stretch.

8. After connecting the air supply, press the PUSH BUTTON AIR VALVE and check that all safety locks are functioning properly. Lower the lift by pressing the push button air valve and power unit lowering valve simultaneously.

⚠ WARNING

KEEP HANDS AND FEET CLEAR. Remove hands and feet from any moving parts. Keep feet clear of lift when lowering. Avoid pinch points.

9. Check all MAIN SAFETY LOCKS to make sure they move freely and spring back to the lock position when released. Lubricate all SAFETY PIVOT points with WD-40 or equal.

10. Run the lift up and down a few times to ensure that the locks are engaging uniformly and that the safety release mechanisms are functioning. Re-adjust if necessary.

STEP 16

(Attaching Approach Ramps/ Tire Stops)

1. Install the approach ramps on the entry side of the lift.
2. For HDSO-14AX use Lower Pin Tube. (See Fig. 16.1)

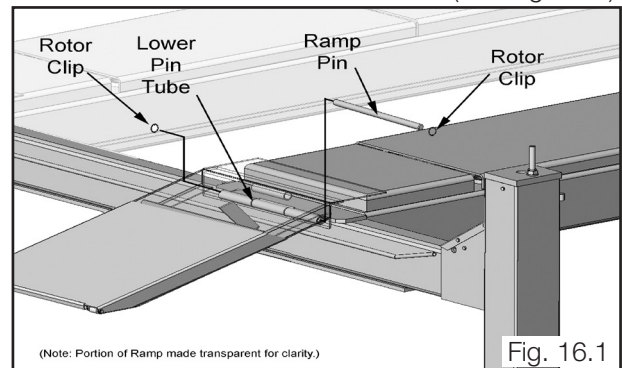

3. Adjust the angle of the raised Approach Ramps using the Bolt and the Locking Nuts on the under side of the Ramps. (See Fig. 16.2)

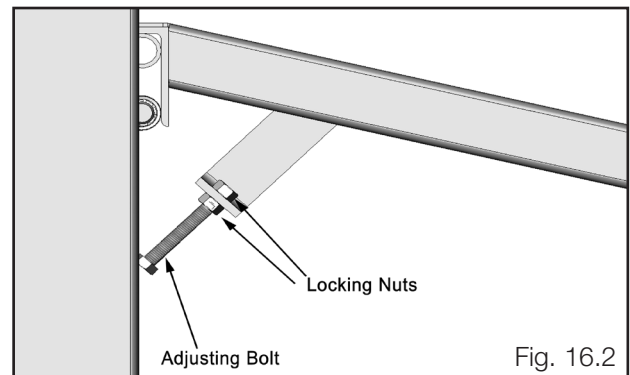

4. Install the Front Tire Stops at the open side of the lift using the M14 x 2 Hex Bolts, Nuts and Washers. (See fig. 16.3)

5. Place the Turnplates in the Turnplate pockets. Insert the Rollback Spacer Bars between the Turnplate and risers as needed for alignment procedures. (See Fig 16.4)

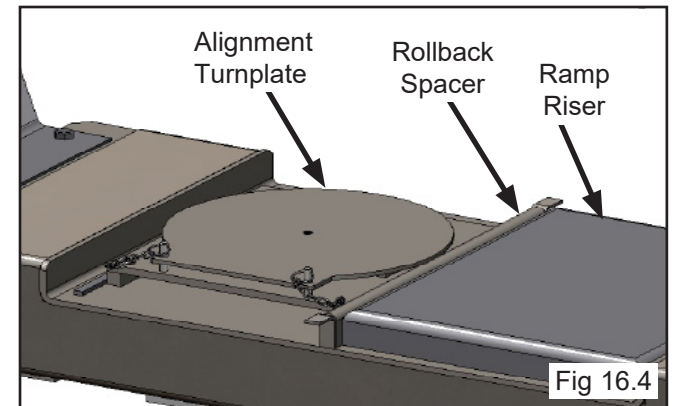
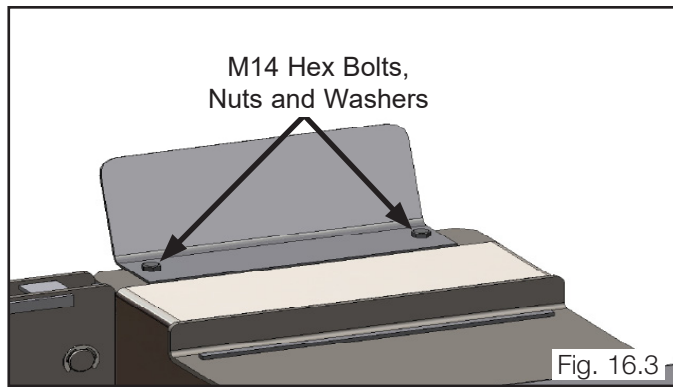

6. Install the four Cross tube Covers. (See Fig. 16.5)

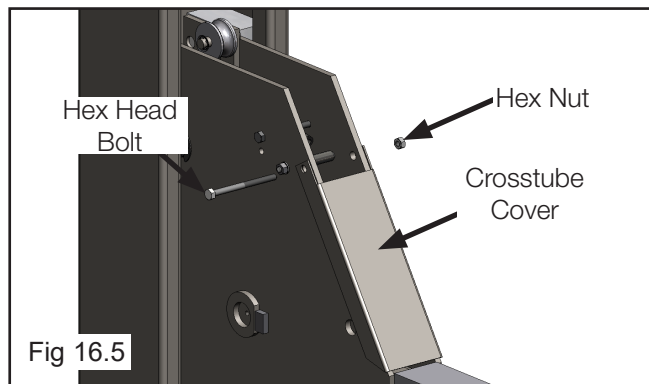

STEP 17

(Leveling / Synchronizing)

1. Using an engineer's automatic Level (transit), locate the Level, at a convenient location in the shop that allows an unobstructed view of all four corners of the runways.

2. Follow the Level manufacturer's instructions for proper setup of the Level. Be sure it is adjusted level in all directions.

3. Raise the lift approximately 30" - 40". Then lower the lift until all primary safeties are engaged in each column and the runways are completely resting on the primary safeties.

4. Place a Level target on the right/front corner of the runway. (See Fig. 17.1)

5. Beginning with "A" position, sight the level to the target and mark the number or the graduation on the inch scale of the target that aligns to the cross hairs of the Level, (See Fig. 17.1)

NOTE:

Use a pencil, marking pen or attach a paper clip onto the target scale at the crosshair reference.

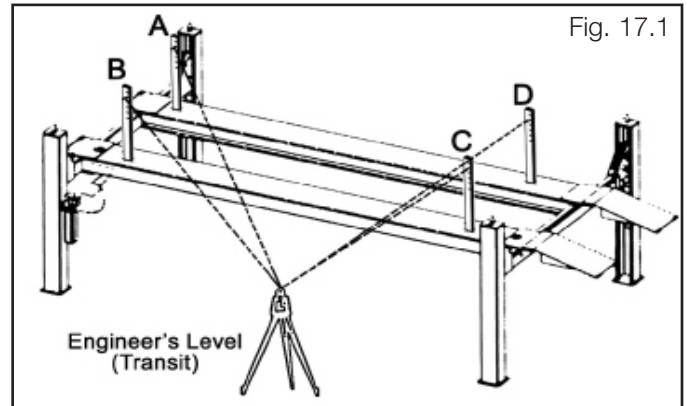

6. Next, move the target and place it at point "B" on the runway. (See Fig. 17.1)

7. Rotate the Level and focus on the target scale.

8. Adjust the adjustment nut on the safety ladder bar at the top of the column at "B" until the crosshairs of the Level align to reference mark on the target scale. (See Fig. 17.1)

9. Repeat steps locating the target assembly at points "C" and "D" and adjusting safety ladders at each corresponding column until the reference mark on the target scale is on the crosshairs of the Level. The runways are now level at all four points. (See Fig. 17.1)

10. To complete the leveling procedures, lock each safety ladder jam nut tightly against bottom of column top plate. (See Fig. 17.2.)

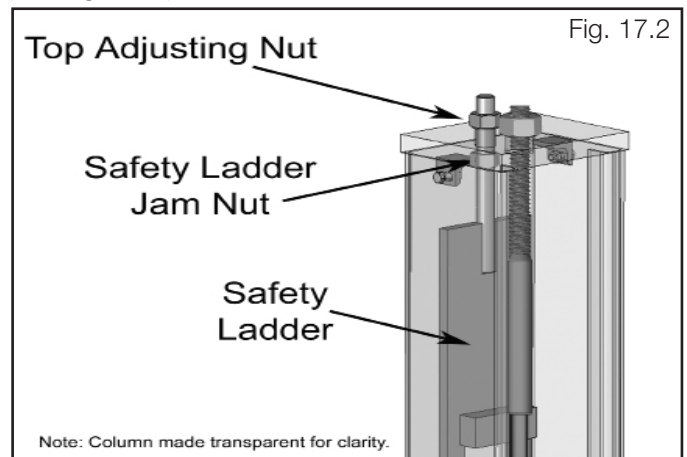

11. Next, load vehicle onto the lift.

12. Raise the lift to full height. Listen and watch as the primary safeties engage the safety ladder. Synchronize by adjusting the cables so that all four latches click at same time. Make necessary adjustments to the cables allowing compensation for stretch.

! WARNING

Safety locks may not engage at exactly the same time when vehicles are being raised. They should be close. Be sure that all four corners have passed the SAME safety ladder bar slot before lowering lift on the safety locks. NEVER lower lift on different safety lock position or damage to the lift may result.

STEP 18

(Adding Grease)

1. Lift must be fully lowered before changing or adding fluid.
2. Add grease fittings to the locations shown on page 44. If the grease fittings are already installed, skip this step.
3. Add grease to the grease fittings.

STEP 19

(Bleeding)

1. Lift must be fully lowered before changing or adding fluid.
2. Raise and lower lift six times. The cylinder is self-bleeding. After bleeding system, fluid level in power unit reservoir may be down. Add more fluid if necessary to raise lift to full height. It is only necessary to add fluid to raise lift to full height.
3. To pressure test, run lift to full rise and run motor for approximately 3-seconds after lift stops. This will place pressure on the hydraulic system. Stop and check all fittings and hose connections. Tighten or reseal if required.

! WARNING

Wheels Chock must be used on the rear wheels. (See Fig 18.1)

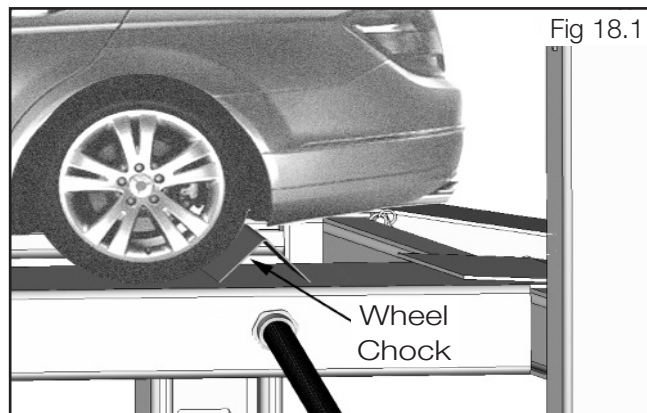

POST-INSTALLATION CHECK-OFF

- Columns properly shimmed and stable
- Anchor Bolts tightened
- Pivot / Sheave Pins properly attached
- Electric power supply confirmed
- Cables adjusted properly
- Safety Locks functioning properly
- Check for hydraulic leaks
- Oil level
- Lubrication of critical components
- Check for overhead obstructions
- All Screws, Bolts, and Pins securely fastened
- Surrounding area clean
- Operation, Maintenance and Safety Manuals on site.
- Perform an Operational Test with a typical vehicle

OPTIONAL EQUIPMENT INSTALLATION

Rolling Jack maximum weight capacity for use with
HDSO-14P or HDSO-14AX is 7,000 lb (3,175 kg) per unit.

HDS/HDSO-14LSX Rolling Jack Air Line Kit Installation Part # 5174009

REV 03/21/2012

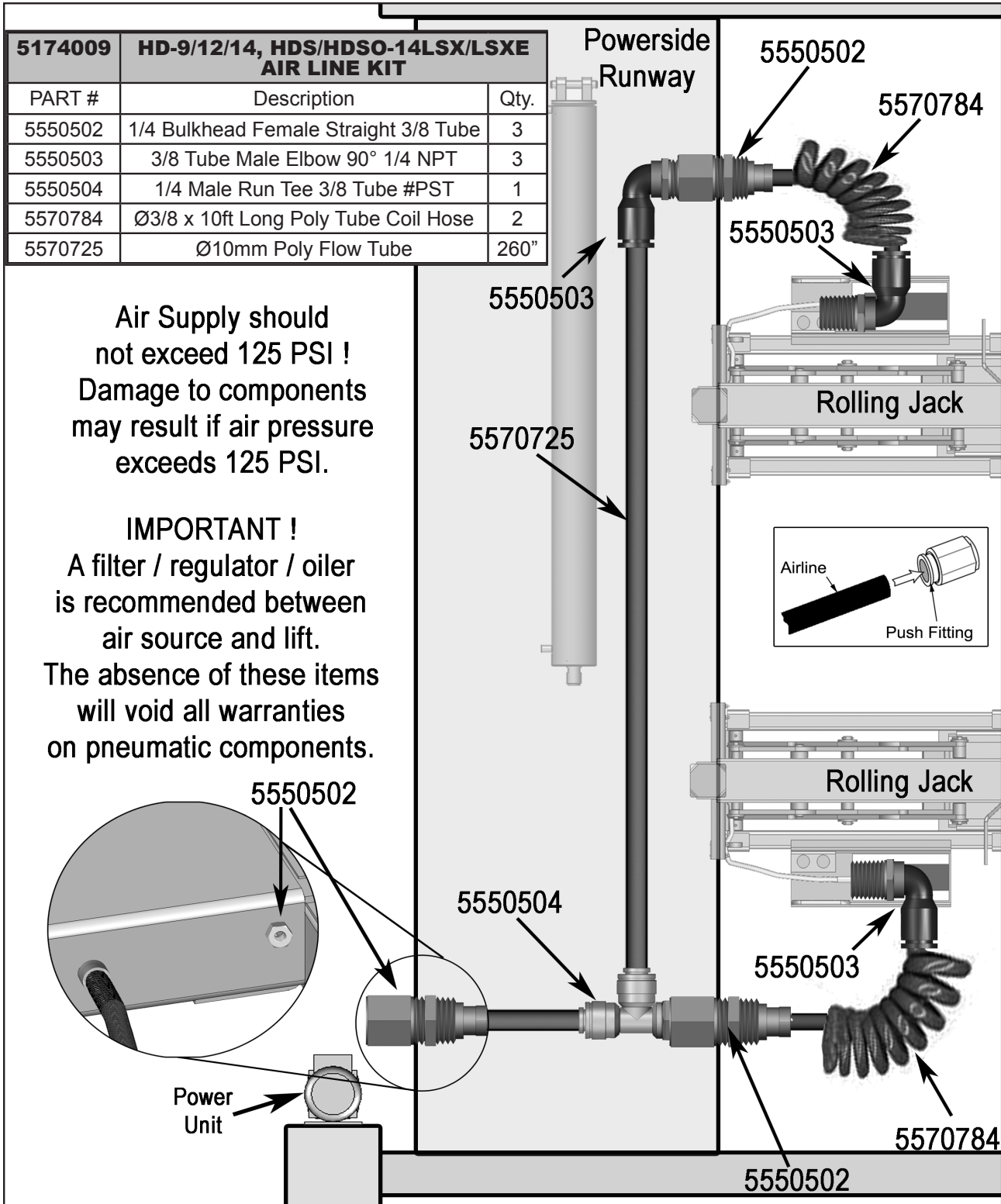

Operate and
Store
Rolling Jacks
Only
Within the
Safe Range
Reccomended
By The
Lift
Manufacturer

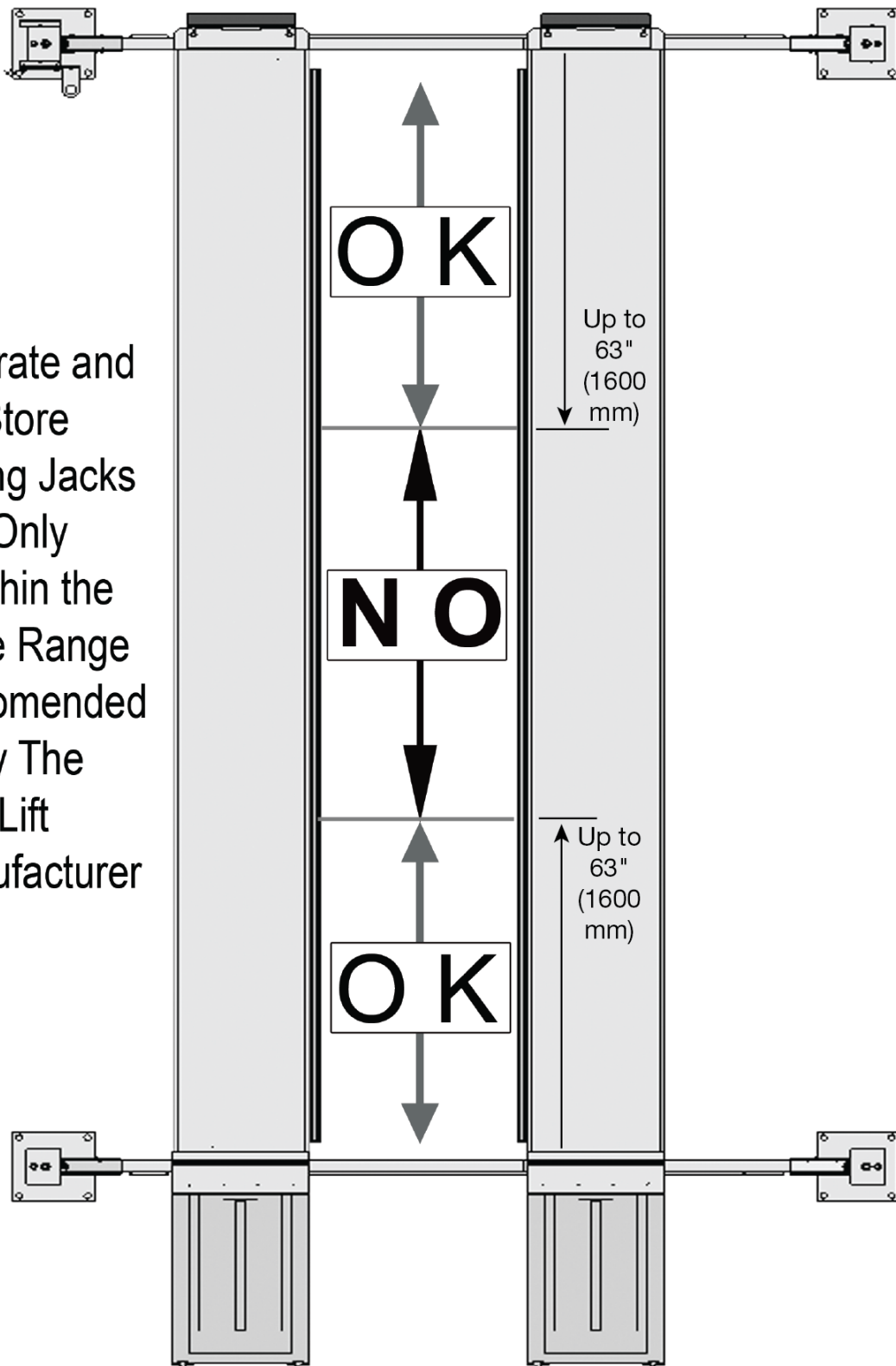

STEP 19

(Operation Instructions)

OWNER/EMPLOYER RESPONSIBILITIES

The Owner/Employer:

- Shall ensure that lift operators are qualified and that they are trained in the safe use and operation of the lift using the manufacturer's operating instructions; ALI/SM01-1, ALI Lifting it Right safety manual; ALI/ST-90 ALI Safety Tips card; ANSI/ALI ALOIM-2000, American National Standard for Automotive Lifts-Safety Requirements for Operation, Inspection and Maintenance; ALI/WL Series, ALI Uniform Warning Label Decals/Placards; and in the case of frame engaging lifts, ALI/LP-GUIDE, Vehicle Lifting Points/Quick Reference Guide for Frame Engaging Lifts.
- Shall establish procedures to periodically inspect the lift in accordance with the lift manufacturer's instructions or ANSI/ALI ALOIM-2000, American National Standard for Automotive Lifts-Safety Requirements for Operation, Inspection and Maintenance; and The Employer shall ensure that lift inspectors are qualified and that they are adequately trained in the inspection of the lift.
- Shall establish procedures to periodically maintain the lift in accordance with the lift manufacturer's instructions or ANSI/ALI ALOIM-2000, American National Standard for Automotive Lifts-Safety Requirements for Operation, Inspection and Maintenance; and The Employer shall ensure that lift maintenance personnel are qualified and that they are adequately trained in the maintenance of the lift.
- Shall maintain the periodic inspection and maintenance records recommended by the manufacturer or ANSI/ALI ALOIM-2000, American National Standard for Automotive Lifts-Safety Requirements for Operation, Inspection and Maintenance.
- Shall display the lift manufacturer's operating

STEP 20

(Lift Operation Safety)



TO AVOID PERSONAL INJURY AND/OR PROPERTY DAMAGE, PERMIT ONLY TRAINED PERSONNEL TO OPERATE LIFT. AFTER REVIEWING THESE INSTRUCTIONS, PRACTICE USING LIFT CONTROLS BY RUNNING THE LIFT THROUGH A FEW UNLOADED CYCLES BEFORE LOADING VEHICLE ON LIFT. **NEVER** RAISE JUST ONE END, ONE CORNER, OR ONE SIDE OF VEHICLE.

instructions; ALI/SM 93-1, ALI Lifting It Right safety manual; ALI/ST-90 ALI Safety Tips card; ANSI/ALI ALOIM-2000, American National Standard for Automotive Lifts-Safety Requirements for Operation, Inspection and Maintenance; and in the case of frame engaging lifts, ALI/LP-GUIDE, Vehicle Lifting Points/Quick Reference Guide for Frame Engaging Lifts; in a conspicuous location in the lift area convenient to the operator.

- Shall provide necessary lockout/tagout means for energy sources per ANSI Z244.1-1982 (R1993), Safety Requirements for the Lockout/Tagout of Energy Sources, before beginning any lift repairs.
- Shall not modify the lift in any manner without the prior written consent of the manufacturer.

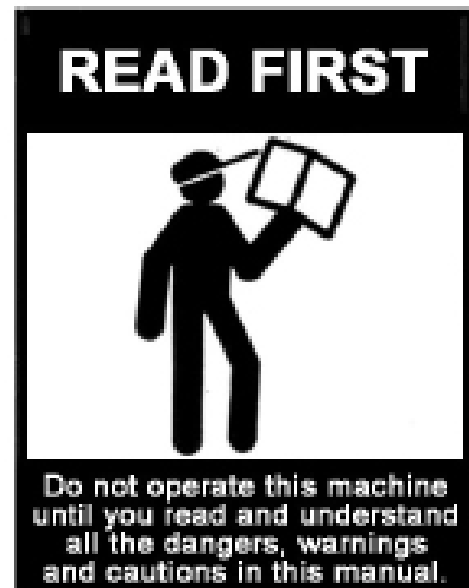

- **DAILY** inspect your lift. Never operate if it malfunctions or if it has broken or damaged parts. Use only qualified lift service personnel and genuine BendPak parts to make repairs.
- **THOROUGHLY** train all employees in use and care of lift, using manufacturer's instructions and "Lifting It Right" and "Safety Tips" supplied with the lift.
- **NEVER** allow unauthorized or untrained persons to position vehicle or operate lift.
- **PROHIBIT** unauthorized persons from being in shop area while lift is in use.
- **DO NOT** permit anyone on lift or inside vehicle when it is either being raised or lowered.

LIFT OPERATION SAFETY (CONT'D)

- **ALWAYS** keep area around lift free of tools, debris, grease and oil.
- **NEVER** overload lift. Capacity of lift is shown on nameplate affixed to the lift.
- **DO NOT** stand in front of the vehicle while it is being positioned in lift bay.
- **DO NOT** block open or override self-closing lift controls; they are designed to return to the "Off" or Neutral position when released.
- **ALWAYS** remain clear of lift when raising or lowering vehicles.
- **ALWAYS** use safety stands when removing or installing heavy components.
- **DO NOT** go under raised vehicle if safety locks are not engaged.
- **NEVER LEAVE LIFT IN ELEVATED CONDITION** unless all Safety Locks are engaged.
- **AVOID** excessive rocking of vehicle while on lift.
- **ALWAYS CLEAR AREA** if vehicle is in danger of falling.
- **ALWAYS REMOVE** tool trays, stands, etc. before lowering lift.
- **ALWAYS RELEASE** safety locks before attempting to lower lift.
- **DO NOT** position yourself between a wall and the lift. If the vehicle falls in that direction, you may be severely injured or killed.

To Raise Lift;

1. Position vehicle tires in the center of each Runway.
2. Set parking brake and use Wheel Chocks to hold vehicle in position.
3. Before raising vehicle, be sure all personnel are clear of the lift and surrounding area. Pay careful attention to overhead clearances.
4. Raise the lift to the desired height by pressing the push button on the power unit.

NOTE:

ALLOW (2) SECONDS BETWEEN MOTOR STARTS. FAILURE TO COMPLY MAY CAUSE MOTOR BURNOUT.

5. After vehicle is raised to the desired height, lower the lift onto the nearest Safety Lock. Do not allow Cables to become slack. **ALWAYS ENSURE ALL SAFETY LOCKS ARE ENGAGED** before entering work area.



VISUALLY CONFIRM THAT ALL PRIMARY SAFETY LOCKS ARE ENGAGED BEFORE ENTERING WORK AREA. SUSPENSION COMPONENTS USED ON THIS LIFT ARE INTENDED TO RAISE AND LOWER LIFT ONLY AND ARE NOT MEANT TO BE LOAD HOLDING DEVICES. REMAIN CLEAR OF ELEVATED LIFT UNLESS VISUAL CONFIRMATION IS MADE THAT ALL PRIMARY SAFETY LOCKS ARE FULLY ENGAGED AND THE LIFT IS LOWERED ONTO THE SAFETY LOCKS, REFER TO INSTALLATION/OPERATION MANUAL FOR PROPER SAFETY LOCK PROCEDURES AND/OR FURTHER INSTRUCTION.

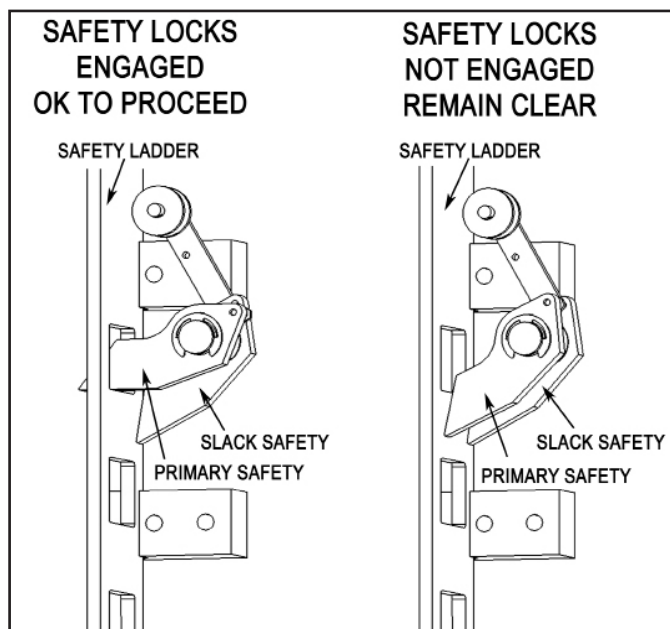

WHEN LOWERING THE LIFT PAY CAREFUL ATTENTION THAT ALL PERSONNEL AND OBJECTS ARE KEPT CLEAR. ALWAYS KEEP A VISUAL LINE OF SIGHT ON THE LIFT AT ALL TIMES. ALWAYS MAKE SURE THAT ALL LOCKS ARE DISENGAGED. IF ONE OF THE LOCKS INADVERTENTLY LOCKS UPON DESCENT THE VEHICLE MAY DISMOUNT CAUSING PERSONAL INJURY OR DEATH.

To Lower Lift;

1. Before lowering vehicle, be sure all personnel are clear of the lift and surrounding area. Pay careful attention to overhead clearances. Ensure all tools and equipment have been cleared from under the lift.

LIFT OPERATION SAFETY (CONT'D)

2. Raise the lift off of the Safety Locks by pressing the push button on the Power Unit. Make sure you raise the lift by at least two inches to allow adequate clearance for the locks to clear.
3. Press the push button air safety valve and HOLD.
4. Push the LOWERING HANDLE on the Power Unit until the lift has descended completely.



IF YOU ARE NOT COMPLETELY FAMILIAR WITH AUTOMOTIVE LIFT MAINTENANCE PROCEDURES; STOP AND CONTACT THE MANUFACTURER FOR INSTRUCTIONS. TO AVOID PERSONAL INJURY, PERMIT ONLY QUALIFIED PERSONNEL TO PERFORM MAINTENANCE ON THIS EQUIPMENT.

DAILY MAINTENANCE

1. Make a visual inspection of ALL MOVING PARTS and check for excessive signs of wear.
2. Check safety locks to ensure they are in good operating condition.
3. Check cables and sheaves for wear. Replace worn parts as required with genuine BendPak parts.
4. Inspect adapters for damage or excessive wear. Replace as required with genuine BendPak parts.

WEEKLY MAINTENANCE

1. Lubricate all Sheave pins and rollers with general purpose oil. (See page 42)
2. Check all Cable connections, bolts, and pins to ensure proper mounting.
3. Lubricate Safety Lock pivot points with general purpose oil or WD-40.

MONTHLY MAINTENANCE

1. Check Safety Locks to ensure they are in good operating condition. Lubricate locking latch shafts. Push release arm several times for oil to penetrate pivot points.
2. Check equalizer cable tension. Adjust per lift installation instructions.
3. Check all Cables for excessive signs of wear.
4. Make a visual inspection of ALL MOVING PARTS and check for excessive signs of wear.
5. Lubricate both Open Front Post surfaces, on both sides, with general purpose grease. (See Fig 19.1)

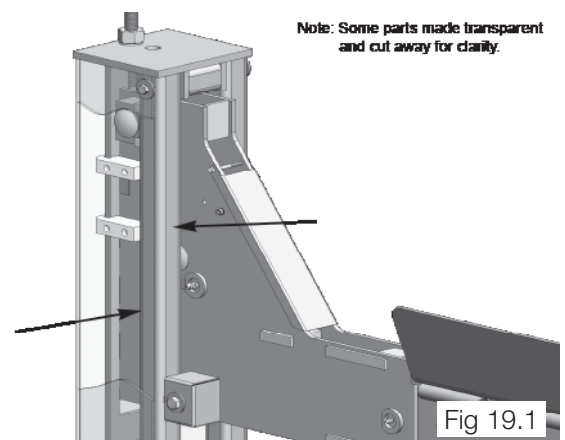

- Lubricate the slide blocks with general purpose grease. Heavy usage may require more frequent lubrication.
- Always call local service representative if electrical problems develop.
- Always replace ALL FAULTY PARTS before lift is put back into operation.
- Every 3 Months: Check anchor bolt torque. Anchors should be torqued to 90 ft/lbs.
- Semi-Annually: Check fluid level of lift power unit and refill if required per lift installation instructions.
- Replace all caution, warning or safety related decals on the lift if unable to read or missing. Reorder labels from BendPak.
- Refer to ANSI/ALI ALOIM booklet for periodic inspection checklist and maintenance log sheet.

⚠ WARNING

WIRE ROPE INSPECTION AND MAINTENANCE

- ◆ Lifting cables should be replaced every three - five years or when visible signs of damage are apparent. DO NOT USE LIFT WITH DEFECTIVE / WORN CABLES.
- ◆ Lifting cables should be maintained in a well-lubricated condition at all times. Wire rope is only fully protected when each wire strand is lubricated both internal and external. Excessive wear will shorten the life of the wire rope. The factory suggested wire rope lubricant that penetrates to the core of the rope and provides long-term lubrication between each individual strand is 90-WT gear oil or ALMASOL® Wire Rope Lubricant. In order to make sure that the inner layers of the rope remain well lubricated, lubrication should be carried out at intervals not exceeding three months during operation.
- ◆ All sheaves and guide rollers in contact with the moving rope should be given regular visual checks for surface wear and lubricated to make sure that they run freely. This operation should be carried out at appropriate intervals generally not exceeding three months during operation. For all sheave axles, the factory recommends standard wheel bearing grease. For all sheaves and/or guide rollers, the factory recommends 90-WT gear oil or similar heavy lubricant applied by any method including pump / spray dispensing, brush, hand and/or swabbing.

HOW OFTEN TO INSPECT

- ◆ Lifting cables should be visually inspected at least once each day when in use, as suggested by American Petroleum Institute (API) RP54 guidelines.
- ◆ Any lifting cables that have met the criteria for removal must be immediately replaced.

WHEN TO REPLACE LIFTING CABLES DUE TO BROKEN WIRES

- ◆ Lifting cables should be removed from service when you see six randomly distributed broken wires within any one lay length, or three broken wires in one strand within one lay length.

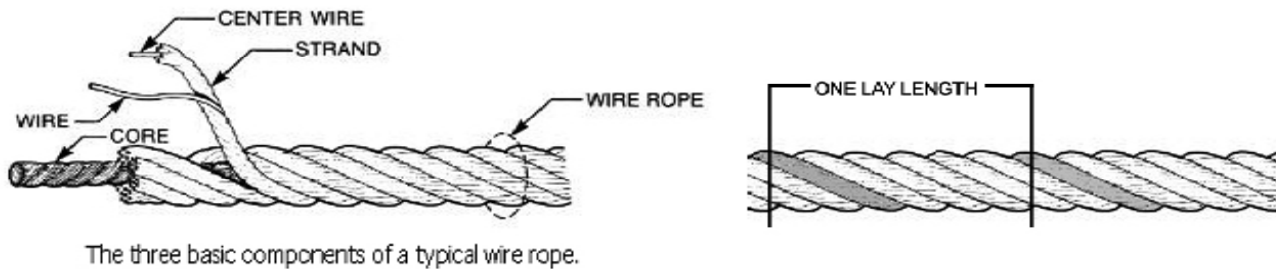

OTHER REASONS TO REPLACE LIFTING CABLES

- ◆ Corrosion that pits the wires and/or connectors.
- ◆ Evidence of kinking, crushing, cutting, bird-caging or a popped core.
- ◆ Wear that exceeds 10% of a wire's original diameter.
- ◆ Evidence of heat damage.

HOW TO FIND BROKEN WIRES

- ◆ The first step is to relax the rope to a stationary position and move the pick-up points off the sheaves. Clean the surface of the rope with a cloth — a wire brush, if necessary — so you can see any breaks.
- ◆ Flex the rope to expose any broken wires hidden in the valleys between the strands.
- ◆ Visually check for any broken wires. One way to check for crown breaks is to run a cloth along the rope to check for possible snags.
- ◆ With an awl, probe between wires and strands and lift any wires that appear loose. Evidence of internal broken wires may require a more extensive rope examination.

Safe Lift Operation

Automotive and truck lifts are critical to the operation and profitability of your business. The safe use of this and other lifts in your shop is critical in preventing employee injuries and damage to customer's vehicles. By operating lifts safely you can ensure that your shop is profitable, productive and safe.

Safe operation of automotive lifts requires that only trained employees should be allowed to use the lift.

TRAINING SHOULD INCLUDE, BUT NOT LIMITED TO:

- ◆ Proper positioning of the vehicle on the runway. (See manufacturers minimize wheel base loading requirements.)
- ◆ Use of the operating controls.
- ◆ Understanding the lift capacity.
- ◆ Proper use of jack stands or other load supporting devices.
- ◆ Proper use, understanding and visual identification of safety lock devices and their operation.
- ◆ Reviewing the safety rules.
- ◆ Proper housekeeping procedures, (lift area should be free of grease, oil, tools, equipment, trash, and other debris)
- ◆ A daily inspection of the lift should be completed prior to its use. Safety devices, operating controls, lift arms and other critical parts should be inspected prior to using the lift.
- ◆ All maintenance and repairs of the lift should be completed by following the manufacturer's requirements. Lift repair parts should meet or exceed OEM specifications. Repairs should only be completed by a qualified lift technician.
- ◆ The vehicle manufacturer's recommendations should be used for spotting and lifting the vehicle.

LIFT OPERATION SAFETY

- ◆ It is important that you know the load limit. Be careful that you do not overload the lift. If you are unsure what the load limit is, check the data plate found on one of the lift columns or contact the manufacturer.
- ◆ The center of gravity should be followed closely to what the manufacturer recommends.
- ◆ Always make sure you have proper overhead clearance. Additionally, check that attachments, (vehicle signs, campers antennas, etc.) are not in the way.
- ◆ Be sure that prior to the vehicle being raised, the doors, trunk, and hood are closed securely.
- ◆ Prior to being raised, make sure there is no one standing closer than six feet from the lift.
- ◆ After positioning the vehicle on the lift runways, set the emergency brake, make sure the ignition is off, the doors are closed, overhead obstructions are cleared, and the transmission is in neutral.
- ◆ Double check that the automatic chock devices are in position and then when the lift is raised, observe the chocks.
- ◆ Put pads or adapters in the right position under the contact points that have been recommended.
- ◆ The lift should be raised just until the vehicle's wheels are about one foot off the ground. If contact with the vehicle is uneven or it appears that the vehicle is not sitting secure, carefully lower the lift and readjust.
- ◆ Always consider potential problems that might cause a vehicle to slip, i.e., heavy cargo, undercoating, etc.
- ◆ Pay attention when walking under a vehicle that is up on the hydraulic lift.



- ◆ **DO NOT** leave the controls while the lift is still in motion.
- ◆ **DO NOT** stand directly in front of the vehicle or in the bay when vehicle is being loaded or driven into position.
- ◆ **DO NOT** Go near vehicle or attempt to work on the vehicle when being raised or lowered.
- ◆ **REMAIN CLEAR** of lift when raising or lowering vehicle.
- ◆ **DO NOT** rock the vehicle while on the lift or remove any heavy component from vehicle that may cause excessive weight shift.
- ◆ **DO NOT** lower the vehicle until people, materials, and tools are clear
- ◆ **ALWAYS ENSURE** that the safeties are engaged and lowered on to the safety ladders before any attempt is made to work on or near vehicle.
- ◆ Some vehicle maintenance and repair activities may cause the vehicle to shift. Follow the manufacturer's guidelines when performing these operations. The use of jack stands or alternate lift points may be required when completing some repairs.
- ◆ **READ AND UNDERSTAND** all safety warning procedures before operating lift.
- ◆ **KEEP HANDS AND FEET CLEAR.** Remove hands and feet from any moving parts. Keep feet clear of lift when lowering. Avoid pinch points.
- ◆ **ONLY TRAINED OPERATORS** should operate this lift. All non-trained personnel should be kept away from work area. Never let non-trained personnel come in contact with, or operate lift.
- ◆ **USE LIFT CORRECTLY.** Use lift in the proper manner. Never use lifting adapters other than what is approved by the manufacturer.
- ◆ **DO NOT** override self-closing lift controls.
- ◆ **CLEAR AREA** if vehicle is on danger of falling.
- ◆ **STAY ALERT.** Watch what you are doing. Use common sense. Be aware.
- ◆ **CHECK FOR DAMAGED PARTS.** Check for alignment of moving parts, breakage of parts or any condition that may affect its operation. Do not use lift if any component is broken or damaged.
- ◆ **NEVER** remove safety related components from the lift. Do not use lift if safety related components are damaged or missing.
- ◆ When the lift is being lowered, make sure everyone is standing at least six feet away.
- ◆ Be sure there are no jacks, tools, equipment, left under the lift before lowering.
- ◆ Always lower the vehicle down slowly and smoothly.

LIFT WILL NOT RAISE

POSSIBLE CAUSE

1. Air in oil, (1,2,8,13)
2. Cylinder binding, (9)
3. Cylinder leaks internally, (9)
4. Motor run backward under pressure, (11)
5. Lowering valve leaks, (3,4,6,10,11)
6. Motor runs backwards, (7,14,11)
7. Pump damaged, (10,11)
8. Pump won't prime, (1,8,13,14,3,12,10,11)
9. Relief valve leaks, (10,11)
10. Voltage to motor incorrect, (7,14,11)

REMEDY

1. Check for proper oil level.
2. Bleed cylinders.
3. Flush- Release valve to get rid of.
possible contamination
4. Dirty oil.
5. Tighten all fasteners.
6. Check for free movement of release.
7. Check motor is wired correctly.
8. Oil seal damaged or cocked
9. See Installation Manual
10. Replace with new part
11. Return unit for repair
12. Check pump-mounting bolts
13. Inlet screen clogged
14. Check wall outlet voltages and wiring

INSTRUCTION

- The oil level should be up to the bleed screw in the reservoir with the lift all the way down.
- See Installation Manual.
- Hold release handle down and start unit allowing it to run for 15 seconds.
- Replace oil with clean Dexron ATF.
- Tighten fasteners to recommended torques.
- If handle does not move freely, replace bracket or handle assembly.
- Compare wiring of motor to electrical diagram on drawing.
- Replace oil seal around pump shaft.
- Consult Lift Manufacturer.
- Replace with new part.
- Return unit for repair.
- Bolts should be 15 to 18 ft. lbs.
- Clean inlet screen or replace.
- Make sure unit and wall outlet are wired properly.

MOTOR WILL NOT RUN

POSSIBLE CAUSE

1. Fuse blown, (5,2,1,3,4)
2. Limit switch burned out, (1,2,3,4)
3. Microswitch burned out, (1,2,3,4)
4. Motor burned out, (1,2,3,4,6)
5. Voltage to motor incorrect, (2,1,8)

REMEDY

1. Check for correct voltage
2. Check motor is wired correctly
3. Don't use extension cords
4. Replace with new part
5. Reset circuit breaker/fuse
6. Return unit for repair
7. See Installation Manual
8. Check wall outlet voltage and wiring

INSTRUCTION

- Compare supply voltage with voltage on motor nametag. Check that the wire is sized correctly. N.E.C. table 310-12 requires AWG 10 for 25 Amps.
- Compare wiring of motor to electrical diagram on drawing.
- According to N.E.C. : " The size of the conductors... should be such that the voltage drop would not exceed 3% to the farthest outlet for power..." Do not run motor at 115 VAC – damage to the motor will occur.
- Replace with new part.
- Reset circuit breaker/fuse.
- Return unit for repair.
- See Installation Manual.
- Make sure unit and wall outlet is wired properly. Motor must run at 208/230 VAC.

LIFT LOWERS SLOWLY OR NOT AT ALL

POSSIBLE CAUSE

1. Cylinders binding, (1)
2. Release valve clogged, (5,4,2,3)
3. Pressure fitting too long, (6)

REMEDY

1. See Installation Manual
2. Replace with new part
3. Return for repair
4. Check oil.
5. Clean release valve
6. Replace fitting with short thread lead

INSTRUCTION

- Consult Lift Manufacturer.
- Replace with new part.
- Return for repair.
- Use clean 10-WT hydraulic oil or Dexron-III automatic transmission fluid only. If ATF is contaminated, replace with clean ATF and clean entire system.
- Wash release valve in solvent and blow out with air.
- Replace fitting with short thread lead.

WILL NOT RAISE LOADED LIFT

POSSIBLE CAUSE

1. Air in oil, (1,2,3,4)
2. Cylinder binding, (5)
3. Cylinder leaks internally, (5)
4. Lift overloaded, (6,5)
5. Lowering valve leaks, (7,8,1,5,9)
6. Motor runs backwards, (10,12,9)
7. Pump damaged, (5,9)
8. Pump won't prime, (1,2,3,4,5,11,9)
9. Relief valve leaks, (8,5,9)
10. Voltage to motor incorrect, (10,12,5)

REMEDY

- | REMEDY | INSTRUCTION |
|--|--|
| 1. Check oil level | The oil level should be up to the bleed screw in the reservoir [with the lift all the way down.] |
| 2. Check/Tighten inlet tubes | Replace inlet hose assembly. |
| 3. Oil seal damaged or cocked | Replace oil seal and install. |
| 4. Bleed cylinders | See Installation Manual. |
| 5. See Installation Manual | Consult Lift Manufacturer. |
| 6. Check vehicle weight | Compare weight of vehicle to weight limit of the lift. |
| 7. Flush release valve | Hold release handle down and start unit allowing it to run for 15 seconds. |
| 8. Replace with new part | Replace with new part. |
| 9. Return unit for repair | Return unit for repair. |
| 10. Check motor is wired correctly | Compare wiring of motor to electrical diagram on power unit drawing. |
| 11. Inlet screen clogged | Clean inlet screen or replace. |
| 12. Check wall outlet voltage and wiring | Make sure unit and wall outlet is wired properly. |

IMPORTANT

If vehicle becomes stranded in the air, follow all operation instructions as shown on pages 32, 33, 39 and 40. If after observing that all mechanical locks are released and the lift still fails move following all standard operating procedures, immediately stop using the lift and contact factory or factory approved service center for further instructions.

LIFT WILL NOT STAY UP

POSSIBLE CAUSE

1. Air in oil, (1,2,3)
2. Check valve leaks, (6)
3. Cylinders leak internally, (7)
4. Lowering valve leaks, (4,5,1,7,6)
5. Leaking fittings, (8)

REMEDY

1. Check oil level The oil level should be up to the bleed screw in the reservoir with the lift all the way down.
2. Oil seal damaged and cocked Replace oil seal around pump shaft.
3. Bleed cylinder Refer to Installation Manual.
4. Flush release valve Hold release handle down and start unit allowing it to run for 15 seconds.
5. Replace with new valve Replace with new valve.
6. Return unit for repair Return unit for repair.
7. See Installation Manual Consult Lift Manufacturer.
8. Check complete hydraulic system for leaks. Tighten all hydraulics fittings and inspect all hoses.

INSTRUCTION

Grease Port / Lubrication Locations

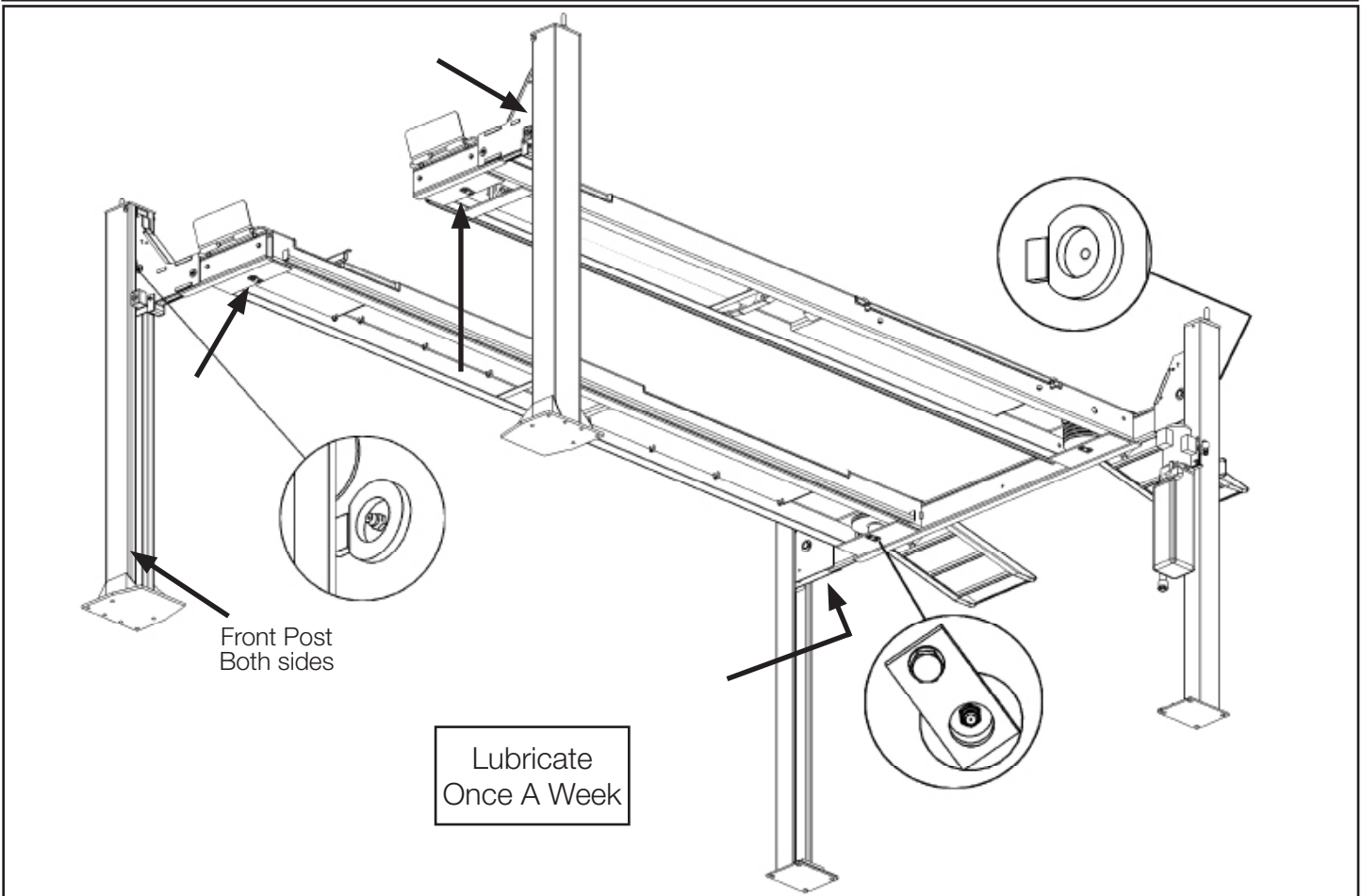

A**B**

⚠ DANGER

VISUALLY CONFIRM THAT ALL PRIMARY SAFETY LOCKS ARE ENGAGED BEFORE ENTERING WORK AREA.

Suspension components on this lift are intended to raise and lower lift; they are NOT load-holding devices. Do not go under an elevated lift until visual confirmation is made that the lift is engaged on its Safety Locks. Refer to the manual for proper Safety Lock procedures and additional instructions.

VÉRIFIER VISUELLEMENT QUE TOUS LES VERROUS DE SÉCURITÉ PRIMAIRES SONT ENGAGÉS AVANT D'ENTRER DANS LA ZONE DE TRAVAIL.

Les composants de suspension de cet élévateur sont destinés à élever et abaisser l'ascenseur, ce ne sont PAS des dispositifs de maintien de la charge. Ne passez pas sous un ascenseur surélevé avant d'avoir obtenu la confirmation visuelle que l'ascenseur est engagé sur ses serrures de sécurité. Reportez-vous au manuel pour connaître les procédures de verrouillage de sécurité et les instructions supplémentaires.

⚠ WARNING

Wire Rope Inspection and Maintenance

- Replace lifting cables if wear or damage is evident, such as excessive broken strands, kinks, deformities, or areas of heavy abrasion.
- Keep wire rope in a well-lubricated condition at all times. Wire rope is only fully protected when each wire strand is lubricated, both internally and externally. Excessive wear shortens the life of wire rope. Use wire rope lubricant that penetrates to the core of the rope and provides long-term lubrication between individual strands. Lubrication should be done at least every three months during normal operation.
- All sheaves and guide rollers in contact with the moving wire rope should be given regular visual checks for surface wear and lubricated to make sure they run freely. This should be done at least every three months during normal operation. For sheave axles, use standard wheel-bearing grease. For all sheaves and/or guide rollers, use 90-WT gear oil or similar heavy lubricant applied by any method including pump/spray dispensing, brush, hand, and/or swabbing.

Failure to read, understand, and follow these instructions may cause death or serious injury. Read and understand these instructions before using lift.

⚠ ATTENTION

Inspection et maintenance des câbles

- Remplacez les câbles de levage si l'usure ou des dommages sont évidents, tels que des brins cassés, des fentes, des déformations ou des zones de forte abrasion excessives.
- Gardez le câble métallique bien lubrifié en tout temps. Le câble métallique n'est entièrement protégé que lorsque chaque brin est lubrifié, à la fois à l'intérieur et à l'extérieur. Une usure excessive raccourcit la durée de vie du câble. Utilisez un lubrifiant pour câble métallique qui pénètre dans le noyau du câble et assure une lubrification à long terme entre les brins. La lubrification doit être effectuée au moins tous les trois mois en fonctionnement normal.
- Toutes les poulies et les galets de guidage en contact avec le câble métallique en mouvement doivent être soumis à des contrôles visuels réguliers de l'usure de la surface et lubrifiés pour s'assurer qu'ils fonctionnent librement. Cela devrait être fait au moins tous les trois mois pendant le fonctionnement normal. Pour les axes de poulie, utilisez de la graisse standard pour roulement de roue. Pour toutes les poulies et/ou les galets de guidage, utilisez de l'huile pour engrenages 90-WT ou un lubrifiant lourd similaire, appliqué selon n'importe quelle méthode, y compris la distribution par pompe / spray, brosse, main et/ou essuyage.

Lisez et comprenez ces instructions avant d'utiliser l'ascenseur. Ne pas lire, comprendre et suivre ces instructions peut provoquer des blessures graves, voire mortelles.

IMPORTANT OPERATION / MAINTENANCE INSTRUCTIONS - PLEASE READ

TO RAISE LIFT

- ✓ Position vehicle tires at the center of each platform.
- ✓ Set parking brake or use wheel chock to hold vehicle in position.
- ✓ Before raising vehicle, be sure all personnel are clear of lift and surrounding area. Pay special attention to overhead clearance.
- ✓ Raise lift to desired height by pressing pushbutton on power unit.
- ✓ Maintain visual contact with vehicle and surrounding area at all times while raising lift.
- ✓ Stop immediately if load shifts or becomes unstable.
- ✓ After vehicle is raised to desired height, lower lift onto the nearest Safety Lock. Do not allow cables to become excessively slack.
- ✓ Always make sure all Primary Safety Locks are engaged before entering work area.

TO LOWER LIFT

- ✓ Make sure all personnel, tools, and equipment are clear of lift and surrounding area.
- ✓ Lower lift by pressing pushbutton on power unit. Lower lift at least two inches to allow adequate clearance for locks to clear.
- ✓ Press and hold Pushbutton At Value.
- ✓ Lower vehicle by step pressing and holding Lowering Handle.
- ✓ When lowering lift, make sure that all personnel and objects are kept clear.
- ✓ Always keep a visual line of sight on lift while lowering.
- ✓ Always make sure safety locks are disengaged. If one of the locks inadvertently engages on descent, lift and/or vehicle may change or cause personal injury or death.

REQUIRED MONTHLY MAINTENANCE

- ✓ Consult operation manual for factory recommended maintenance.
- ✓ Adjust lift cables to ensure lift raises level and Safety Locks engage automatically.
- ✓ Check all drivable connections, bolts and pins to ensure proper mounting.
- ✓ Visually inspect Safety Locks for proper operation.
- ✓ Visually inspect controls. Do not use lift if control shows signs of breakage or other deterioration.
- ✓ Inspect all anchor bolts, replace as necessary.
- ✓ Check posts for squeaking and rattle.
- ✓ Inspect all bolts and other fasteners to make sure they are properly seated.
- ✓ Make a visual inspection of all moving parts and check for signs of excessive wear.
- ✓ Replace all faulty parts before lift is put back into operation.

⚠ WARNING

• Warning: If anchor bolts are loose, or any component of the lift is defective, do not use lift. Do not use until these conditions are corrected.

• Never operate the lift with people or equipment on it.

• Never exceed rated capacity.

• Always ensure Safety Locks are engaged before any attempt is made to work on or near vehicle.

• Do not leave lift elevated unless engaged on Safety Locks.

• Do not permit the electric motor to get wet. Motor damage caused by moisture is not covered by the warranty.

⚠ ATTENTION

• Avertissement: si les boulons d'ancrage sont desserrés ou si l'un des composants de l'élévateur est défectueux, n'utilisez pas d'élévateur! Ce n'est pas sûr dans ces conditions.

• Ne jamais travailler l'ascenseur avec des personnes ou des équipements dessus.

• Ne jamais dépasser la capacité nominale.

• Assurez-vous toujours que les serrures de sécurité sont entièrement engagées avant toute tentative de travail sur ou à proximité du véhicule.

• Ne laissez pas l'ascenseur surélevé si il est engagé sur les verrous de sécurité.

• Ne laissez pas le moteur électrique se mouiller! Les dommages au moteur causés par l'humidité ne sont pas couverts par la garantie.

C

<p>CAUTION Lift to be used by trained operator ONLY.</p>	<p>CAUTION Authorized personnel only in lift area.</p>
<p>The messages and pictographs shown are generic in nature and are meant to generally represent hazards common to all automotive lifts regardless of specific style.</p> <p>Funding for the development and validation of these labels was provided by the Automotive Lift Institute, PO Box 85 Cortland, NY 13045.</p> <p>Replacement label sets may be obtained from the original lift manufacturer and ALI's member companies. They are protected by copyright.</p> <p>www.autolift.org © 2012 by ALI, Inc. ALI/PL/2006</p>	
<p>WARNING Clear area if vehicle is in danger of falling.</p>	<p>WARNING Remain clear of lift when raising or lowering vehicle.</p>
<p>WARNING Keep clear of pinch points when lift is moving.</p>	<p>WARNING Keep feet clear of lift while lowering.</p>
<p>WARNING Do not override self-closing lift controls.</p>	<p>WARNING Chock wheel to prevent vehicle movement.</p>
<p>The messages and pictographs shown are generic in nature and are meant to generally represent hazards common to all automotive lifts regardless of specific style.</p> <p>Funding for the development and validation of these labels was provided by the Automotive Lift Institute, PO Box 85 Cortland, NY 13045.</p> <p>Replacement label sets may be obtained from the original lift manufacturer and ALI's member companies. They are protected by copyright.</p> <p>www.autolift.org © 2012 by ALI, Inc. ALI/PL/2006</p>	
<p>NOTICE Read operating and safety manuals before using lift.</p>	<p>NOTICE Proper maintenance and inspection is necessary for safe operation.</p>
<p>NOTICE Do not operate a damaged lift.</p>	<p>The messages and pictographs shown are generic in nature and are meant to generally represent hazards common to all automotive lifts regardless of specific style.</p> <p>Funding for the development and validation of these labels was provided by the Automotive Lift Institute, PO Box 85 Cortland, NY 13045.</p> <p>Replacement label sets may be obtained from the original lift manufacturer and ALI's member companies. They are protected by copyright.</p> <p>www.autolift.org</p> <p>© 2012 by ALI, Inc. ALI/PL/2006</p>

D

⚠ DANGER

THE MAXIMUM LIFTING CAPACITY FOR THIS LIFT IS DESCRIBED BELOW

Maximum Lifting Capacity 14,000 lbs. / 6,350 kg
Max. Lifting Cap. / Front of Lift Center 7,000 lbs. / 3,175 kg
Max. Lifting Cap. / Rear of Lift Center 7,000 lbs. / 3,175 kg

Exceeding the weight capacity of this lift can damage lift and/or property and may cause personal harm, injury or death to operators and/or bystanders. All vehicles MUST be positioned on lift with CENTER OF GRAVITY midway between adapters and/or centered on runways. Damage to lift due to overloading or misuse IS NOT covered under warranty.

LA CAPACITÉ DE LEVAGE MAXIMUM POUR CE LEVAGE EST DÉCRIT CI-DESSOUS

Capacité de Levage Maximale 14,000 lbs. / 6,350 kg
Max. Capuchon De Levage. / Avant du centre de relèvement 7,000 lbs. / 3,175 kg
Max. Capuchon De Levage. / Arrière du centre de levage 7,000 lbs. / 3,175 kg

Le dépassement de la capacité de poids de cet élévateur peut endommager l'ascenseur et / ou les biens et peut causer des dommages corporels, des blessures voire la mort aux opérateurs et / ou aux passants. Tous les véhicules DOIVENT être placés sur l'élévateur avec le CENTRE DE GRAVITÉ à mi-chemin entre les adaptateurs et / ou au centre des pistes. Dommages à soulever dus à la surcharge ou une mauvaise utilisation N'EST PAS couverte par la garantie.

PN 5005657

G

NOTICE

If attachments, accessories, or configuration modifying components used on this lift are located in the load path and affect operation of the lift, affect the lift electrical listing, or affect intended vehicle accommodation; and if they are not certified for use on this lift, then the certification of this lift shall become null and void. Contact the participant for information pertaining to certified attachments, accessories, or configuration modifying components.

www.autolift.org ©2011 by ALI, Inc. ALI / WLSIA01

H

CERTIFIED AUTOMOTIVE LIFT

ALI CERTIFIED
To the provisions of ANSI/ALI ALCVT-2011 SAFETY REQUIREMENTS FOR CONSTRUCTION, TESTING AND VALIDATION

Automotive Lift Institute, Inc. | Cortland, NY 13045

MET LISTED
Conforms to ANSI/UL 201 SAFETY STANDARD FOR GARAGE EQUIPMENT

MET
MET Laboratories, Inc. | BALTIMORE, MD 21286

Certification Label Serial Number
AL00617000J

E

⚠ ATTENTION ⚠

**MAXIMUM LIFTING CAPACITY
CAPACITÉ DE LEVAGE MAXIMUM**

**14000 Lbs.
6350 Kg.**

PN 5005655

I

BP BendPak Santa Paula, CA USA
www.bendpak.com

MODEL NUMBER	
DESCRIPTION	
LIFT CAPACITY	DATE OF MFG.
ROLLING JACK MAX CAP.	MAX PSI / BAR
VOLTAGE	SERIAL NUMBER
<input type="checkbox"/> 110-240V, 50-60 Hz, 1 Ph <input type="checkbox"/> 208-240V, 50-60 Hz, 1 Ph <input type="checkbox"/> 380-415V, 50-60 Hz, 3 Ph <input type="checkbox"/> 208-440V, 50-60 Hz, 3 Ph	UPC

DANGER! Disconnect Power Before Servicing
WARRANTY VOID IF DATA PLATE IS REMOVED PN 5905953

F

BP BendPak PROVIDING AUTOMOTIVE SERVICE SOLUTIONS
SANTA PAULA, CA USA
WWW.BENDPAK.COM
PN 5905940

LIFT TYPE: SURFACE MOUNT MFG. BPK SEE DATA PLATE FOR PRODUCT DETAILS
POWER: ELECTRIC/HYDRAULIC INSTALLATION - SEE OWNERS GUIDE OR CONTACT FACTORY

SAFETY INSTRUCTIONS: IF ATTACHMENTS, ACCESSORIES OR CONFIGURATION MODIFYING COMPONENTS THAT ARE LOCATED IN THE LOAD PATH, AFFECT OPERATION OF THE LIFT, AFFECT THE LIFT ELECTRICAL LISTING OR AFFECT INTENDED VEHICLE ACCOMMODATION ARE USED ON THIS LIFT AND, IF THEY ARE NOT CERTIFIED FOR USE ON THIS LIFT, THEN THE CERTIFICATION OF THIS LIFT SHALL BECOME NULL AND VOID. CONTACT THE PARTICIPANT FOR INFORMATION PERTAINING TO CERTIFIED ATTACHMENTS, ACCESSORIES OR CONFIGURATION MODIFYING COMPONENTS.

BENDPAK LIFTS ARE SUPPLIED WITH CONCRETE FASTNERS MEETING THE CRITERIA AS PRESCRIBED BY ASTM E488 - 96(2003). LIFT BUYERS ARE RESPONSIBLE FOR ANY SPECIAL REGIONAL STRUCTURAL AND/OR SEISMIC ANCHORING REQUIREMENTS SPECIFIED BY ANY OTHER AGENCIES AND/OR CODES SUCH AS THE UNIFORM BUILDING CODE (UBC) AND/OR INTERNATIONAL BUILDING CODE (IBC).

THE MANUFACTURE, USE, SALE OR IMPORT OF THIS PRODUCT MAY BE SUBJECT TO ONE OR MORE UNITED STATES PATENTS, OR PENDING APPLICATIONS, OWNED BY BENDPAK, INC.
DO NOT REMOVE ENGINEERED BY BENDPAK INC. USA MADE IN CHINA

A
Top of
Each Post

Back of
Powerside
Post

Side of
Powerside
Post

Front of
Powerside
Post

BENDPAK
BP

E

C

B

G

D

H

I or J

F

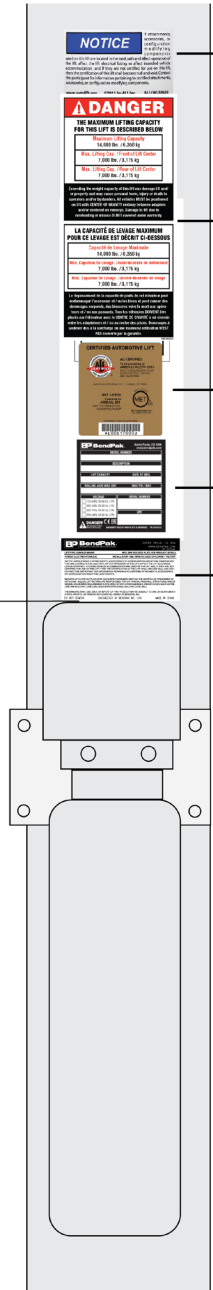
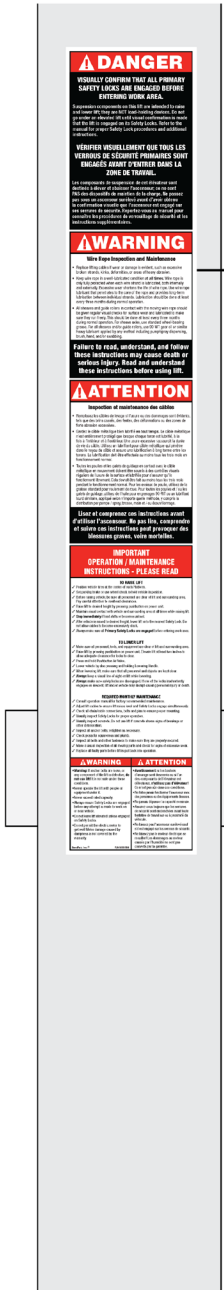
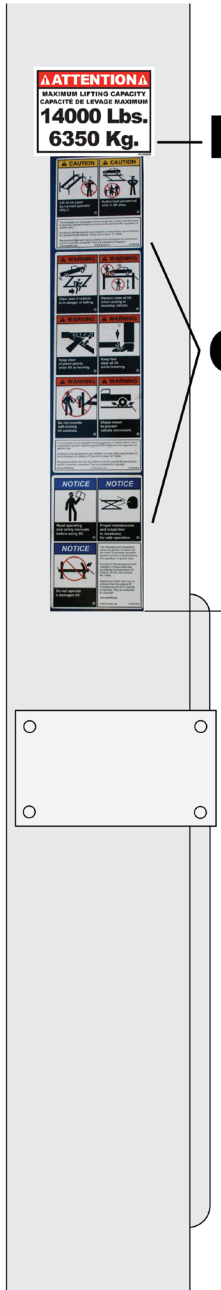

BP BendPak®

R Ranger®