

# Checkpoint Medium Arrow®

Checkpoint® is the first ever wheel nut indicator with wheel overheating indication.

The medium arrow version is designed for the North American market.

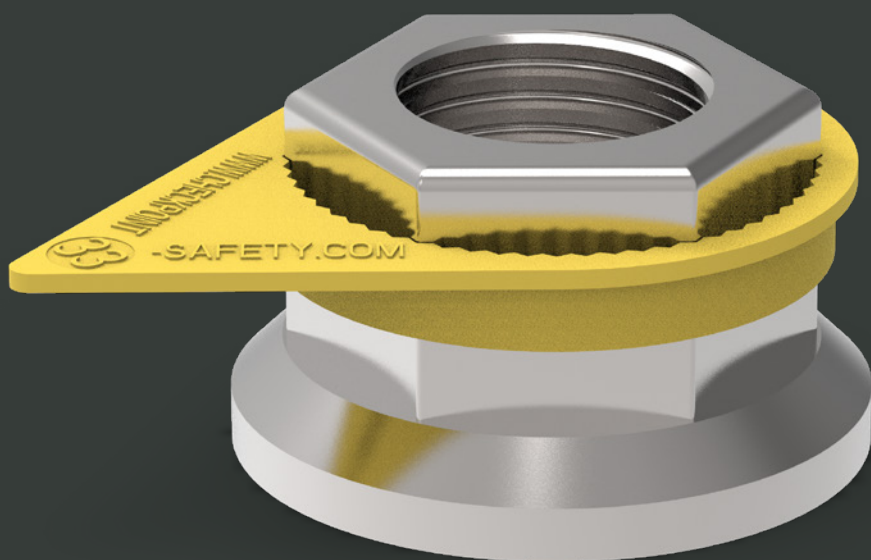

Colour	Size (mm)
Solid Yellow	17
	18
Orange	19
	20
	21
	22
	23
	24
	25
	26
	27
	28
	29
	30
	31
	32
	33
	34
	35
	36
	37
	38
	39
	40
	41
	42
	43
	44
	45
	46
	47
	48
	49
	50

# Checkpoint Medium Arrow®

**Product:** Checkpoint Medium Arrow®  
Yellow 33mm

**Product Code:** CPMAY33

**Function:** The Checkpoint Medium Arrow® visually indicates wheel nut movement. It will also melt to highlight any overheating issues with the wheel. This version is designed for 10 stud wheels with 285 pitch circle diameters (PCDs). [add picture]

**Material:** We use high-grade virgin polymer to ensure product quality and reliability as an overheating indicator.

**Melt temperature:**

125°C/257°F (standard version).

165°C/329°F (HT version).

**Application:** Mainly for commercial vehicles such as trucks, agricultural vehicles, dangerous goods transporters, etc. It is also used in the industrial sector, and wherever safety critical fasteners can loosen due to heavy vibrations.

**Main benefits:** Improves the safety of nut fittings. Enables quick and easy visual checks and monitoring. Reduces maintenance costs by saving time and money.

**Sizes:** All sizes are measured across the flat (a/f) of the nut (in mm). Available in sizes as shown on the front page.

**Colour:** Other colours are available subject to quantity.

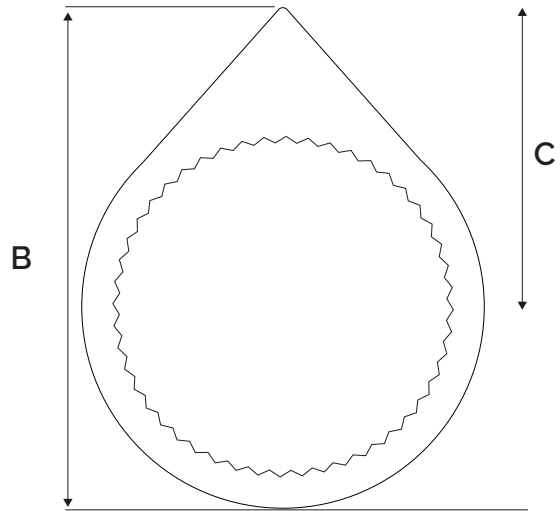

**Specifications:**

A = 7 mm

B = 70 mm

C = 43 mm

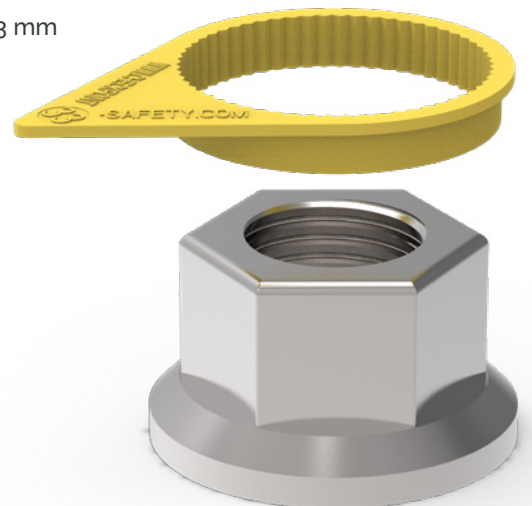

SPECIFICATIONS ARE VALID FOR ALL COLOURS IN THIS SIZE

**GLOBAL LEADERS  
IN WHEEL SAFETY**

Tel: +44 (0)1524 271 200  
info@checkpoint-safety.com  
www.checkpoint-safety.com

**Checkpoint®**  
THE ORIGINAL AND THE BEST