

COATS®

Wheel Lift

Kit 85608609

For use with COATS Models 50xx, 60xx, 70xx

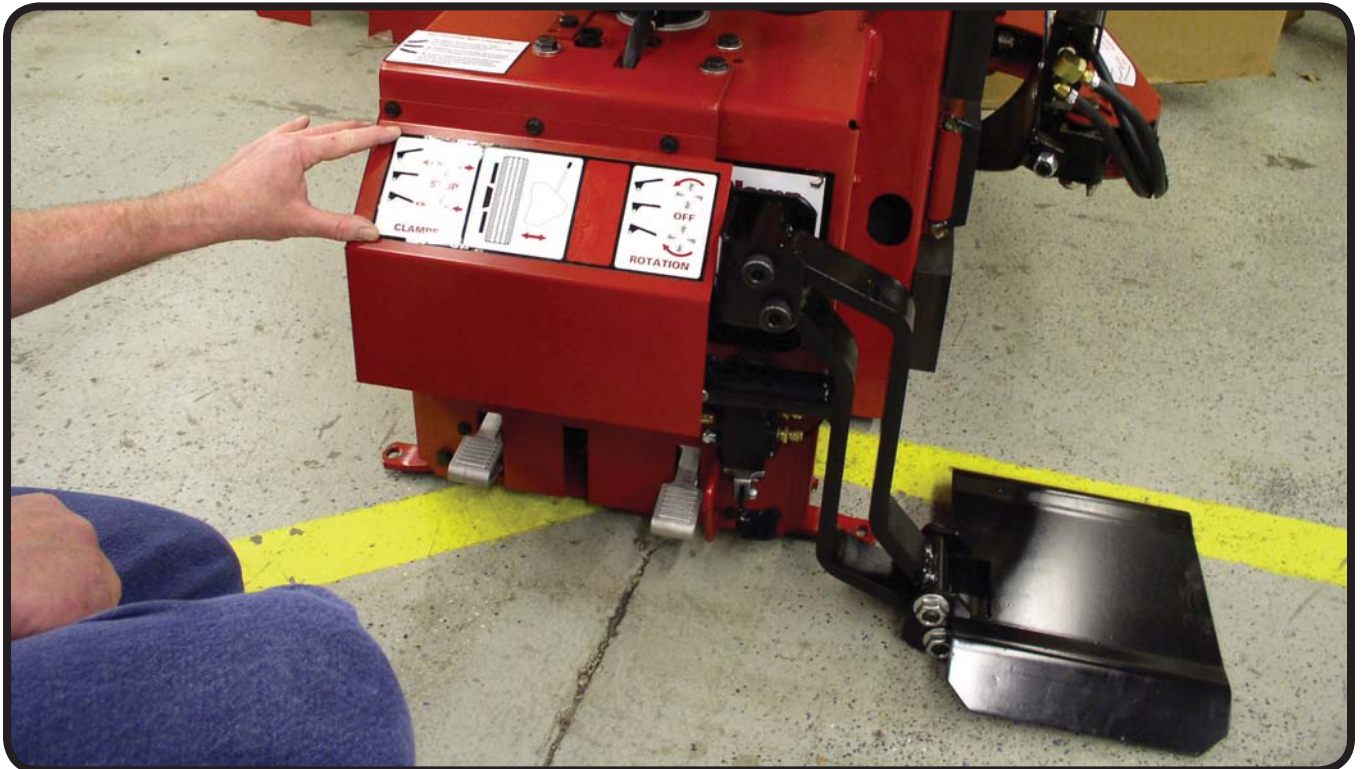

This is a supplement to your operating manual and covers the setup and use of the COATS® Wheel Lift. If you do not have your original operating manual, please call **COATS at 1-800-688-6359** to request an additional copy.

User Instructions with Parts Identification

READ these instructions before placing unit in service. KEEP these and other materials delivered with the unit in a binder near the machine for ease of reference by supervisors and operators.

HENNESSY INDUSTRIES, INC.

1601 J. P. Hennessy Drive, LaVergne, TN USA 37086-3565 615/641-7533 800/688/6359 www.ammcoats.com
HENNESSY INDUSTRIES INC. Manufacturer of AMMCO®, COATS® and BADA® Automotive Service Equipment and Tools.

Manual Part No.: 85608611 02
Revision: 01/14

Wheel Lift Setup



Always **DISCONNECT THE ELECTRICAL POWER** before servicing equipment. This prevents electrical shock or accidental movement of the systems operated by the electrical power.



Always **DISCONNECT AIR SUPPLY** before servicing equipment. This prevents accidental movement of systems operated by compressed air which may result in personal injury. **BLEED THE AIR SYSTEM** by actuating all the valves.



STAY CLEAR OF MOVING PARTS when reconnecting the unit of the air supply. The position of control valves may have changed during the servicing of the machine.



Do not operate machine without the anti-tip bracket installed. It is required for maximum machine stability, when wheel lift is operated under load that would shift the center of gravity.

50xx, 60xx, 70xx Series Instructions

Before beginning this modification or attempting any maintenance, remove the electrical power and air source from the machine; also, bleed off any stored compressed air by exhausting through the air blast foot valve.

1. Remove the lower bead loosener pad; reserving the bolts.
2. Next, align slots in the anti-tip bracket with the holes in the chassis where the lower bead loosener pad was attached.



3. Now reassemble the lower bead loosener pad over the anti-tip bracket, as shown.

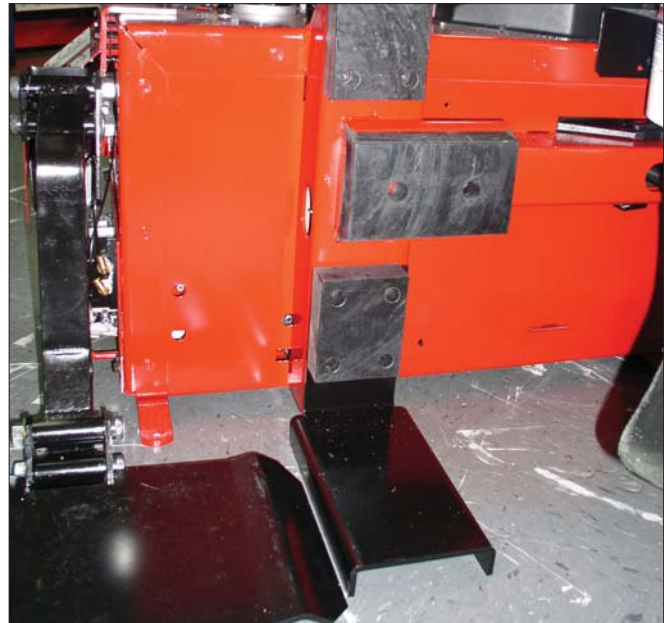

4. Remove pedal bracket guard and reserve the bolts.



5. Remove the machine's side panel using a speed handle or drill and 3/8-inch socket.



6. Locate and cut in half the 3/8-inch hose that connects the oil injector to the first pedal valve.

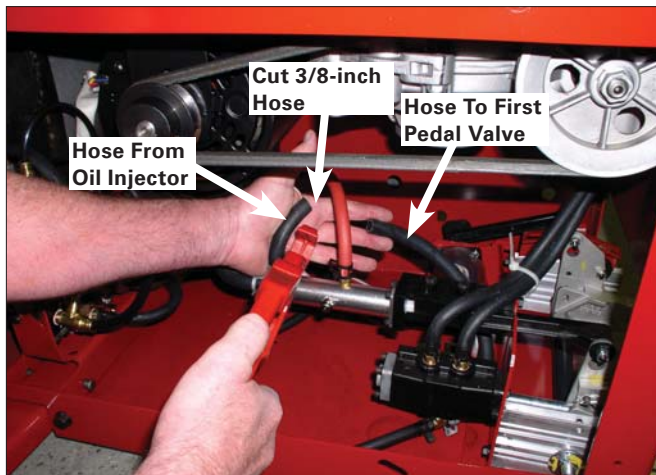

7. Find the tee fitting, on the new pedal bracket assembly, and route it through the front opening to the inside of the chassis.

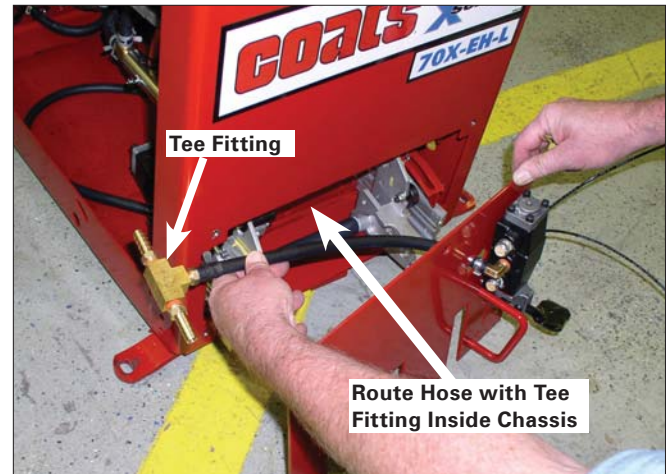

8. Install the tee fitting, from the new pedal bracket assembly, into the just cut 3/8-inch hose and secure using hose clamps.



9. Use three of the four reserved bolts to fasten the new pedal bracket assembly to the front of the machine chassis. Note the pedal valve's position makes it so the fourth both cannot be fastened.



10. Remove two bolts from transmission (see step 8). Reserve bolts for later use.

11. Place lift mounting bracket on chassis and align on the holes. Now install the lift mounting bracket to the chassis using the two reserved bolts from step 10.

Important: Torque bolts at 30 foot pounds.

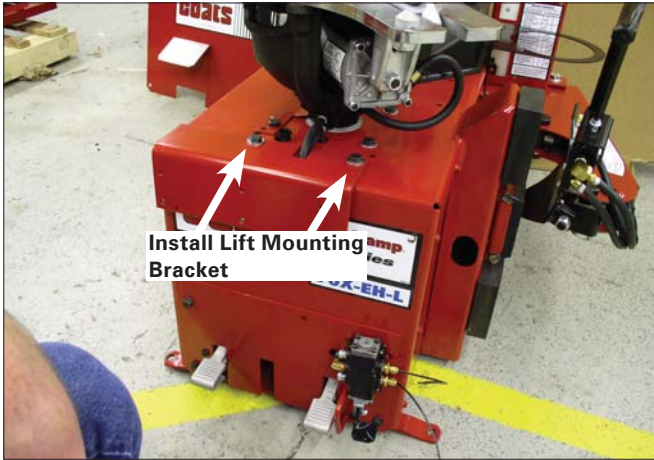

12. Install the wheel lift assembly to the lift mounting bracket using three thread cutting screws.

13. Route the two 1/8-inch tubes, from the lift pedal valve, behind the lift bracket and connect the tubes to the lift cylinder.

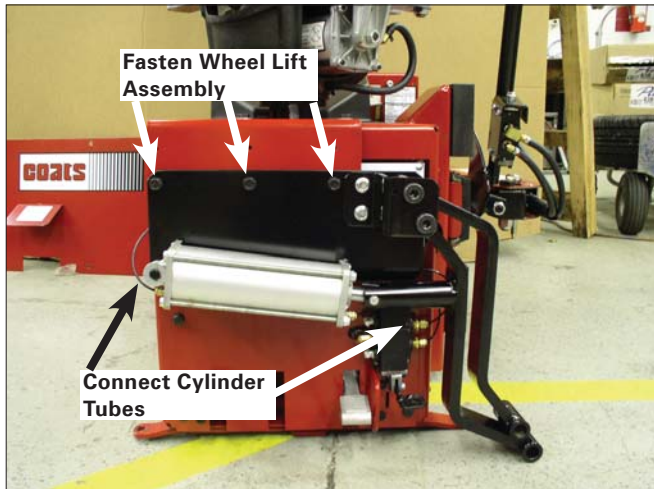

14. Assemble the lift pad to the lift assembly using the supplied shoulder bolt. Be sure to grease the shoulder bolt and tighten it securely.



15. Reconnect air supply and machine test checking for air leaks.

Important: Upon initial air supply connection, it is normal if the Tire Lift jumps 2 or 3 inches the first time it lifts, so be careful and expect that to happen.

16. Attach the new pedal bracket cover using supplied thread cutting screws.

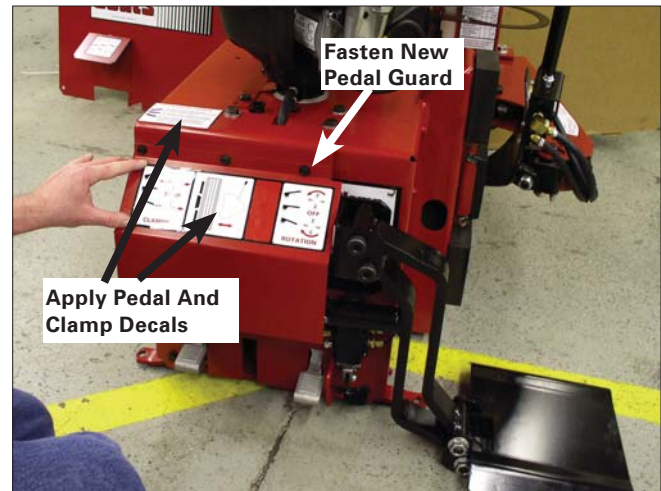

17. Apply new pedal and clamp instruction decals.

18. Reassemble side panel.

Wheel Lift Operating Instructions



Do not operate machine without the anti-tip bracket installed. It is required for maximum machine stability, when wheel lift is operated under load that would shift the center of gravity.

1. Position table top as shown with open portion of the table top facing the wheel lift.



2. With wheel assembly on wheel lift. Keep wheel vertical and push foot pedal down to raise wheel up.

3. Roll tire off wheel lift platform and onto the back of the clamp that is located at the back of the machine closest to wheel lift.



4. With the tire resting on the back of the clamp, lower it so that the rim fits in the clamps.

5. Push foot pedal up to lower wheel lift before performing tire change.

Parts Identification

Note: Fittings have a sealant coating as purchased. If absent, be sure to apply teflon tape or thread sealant at installation.

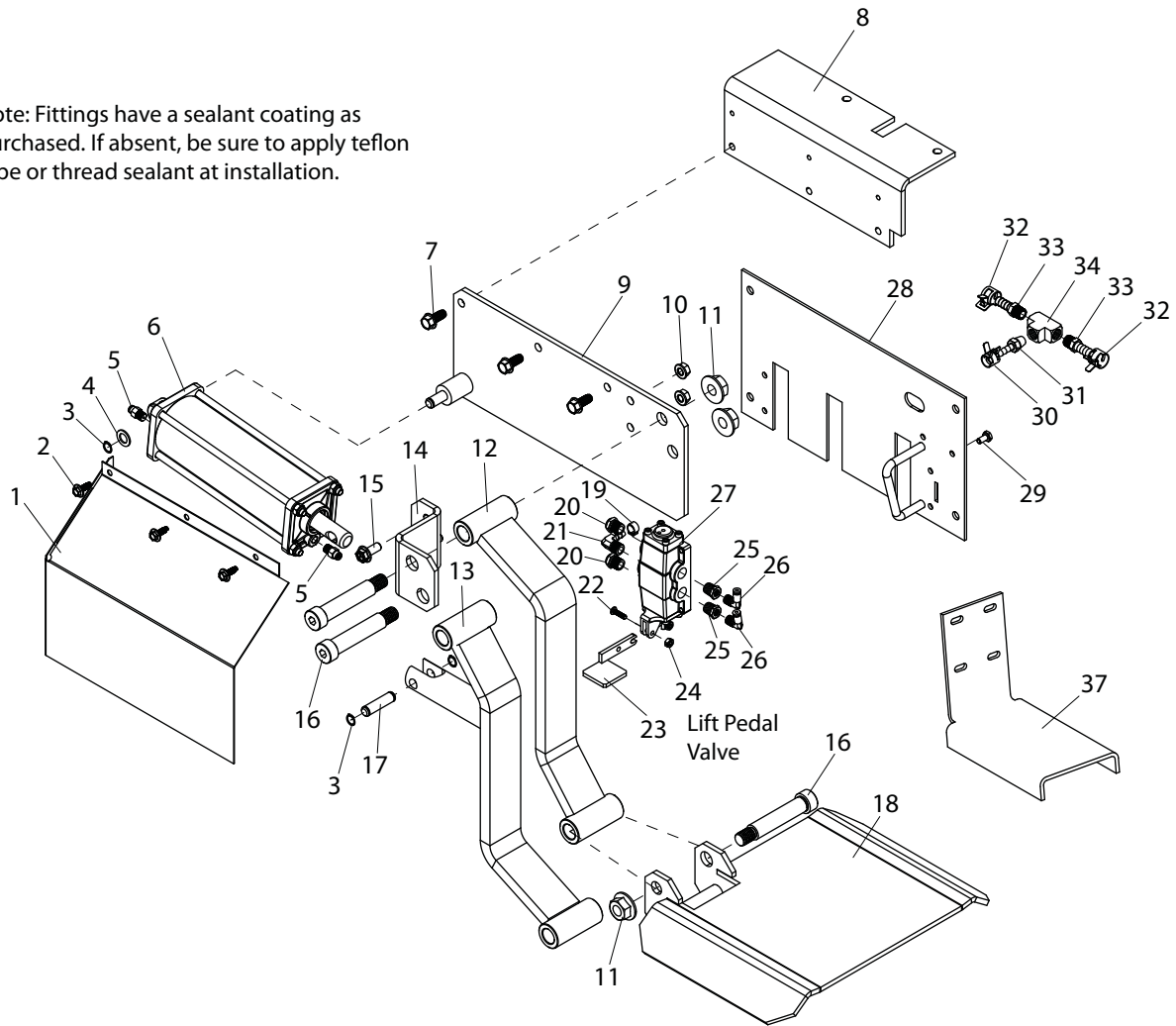

ITEM	PART NO.	DESCRIPTION
1	85608597	Lift Cover
2	8106301	1/4" Hex Hd Self Tap Screw, Gr.5
3	85606919	Ext. Retaining Ring
4	85606917	Flat Washer
5	8181996	Male Straight Fitting
6	85608531	Lift Cylinder Assembly
7	8102459	3/8" Self Tap Screw Gr.5
8	85608587	Chassis Mount Bracket
9	85608588	Lift Mount Assembly
10	8106303	3/8" Whiz Lock Nut, Gr.5
11	8120055	Clamp Carrier Nut
12	85608592	Lift Upper Arm
13	85608595	Lift Lower Arm
14	85608591	Lift Pivot Bracket
15	8106302	3/8" Whiz Lock Screw, Gr.5
16	85608606	SHSS Screw
17	85608602	Lift Pivot Cylinder Rod
18	85608598	Lift Pad
19	8105822	9/16 I.D. Hose Clamp
20	85607855	1/4 NPT Muffler, Small
21	8000376	ELL 90° 1/4 Hose Fitting
22	8181983	0.375-16 Hex Whizlock Nut
23	85608603	Valve Pedal
24	8182682	10-24 Nylon Insert Lock Nut Gr.5
25	8109481	1/4 NPT x 1/8 NPT RDCR Fitting
26	8181997	90° Elbow 1/8 NPT x 1/8" Fitting
27	85608534	Lift Valve
28	85608571	Bracket Assembly
29	902189	1/4-20 x.504 HHCS
30	85606362	13mm Spring Hose Clamp
31	8000378	1/4" Brass St. Fitting
32	85606363	16mm Spring Hose Clamp
33	8101898	St. 1/4" NPT 3/8" Hose Fitting
34	8000643	1/4" NPT Tee
**35	8099050	1/4" Hose
**36	8099075	1/8" Tube
37	85609355	Anti-tip Bracket

**Not Shown

