



RING MASTER

O-Ring/Lock Ring Installer MODEL 70162

MADE IN
USA



SCAN TO SEE
IN ACTION!



FEATURES

- 1 Adjustable Arms Push Against Rim
- 2 Adjustable Feet - To Fit Width of the Rim
- 3 Stacker Pieces - To adjust Area of Extension
- 4 Easy Action Rotating Arm - For Lock Ring Removal

BENEFITS

- ▶ Lightweight and Easy to Use
- ▶ Pushes & Holds Rim Flange/Tire Back for Easy O-Ring/Lock Ring Installation
- ▶ Portable- Fits in Tire Truck Tool Box. Eliminates use of Boom Crane & Cumbersome Tire Tools
- ▶ Easy One Man Operation
- ▶ Works on all 3 Piece & 5 Piece Rim/Wheels up to 39" in Diameter
- ▶ Eliminates Danger of Pushing Equipment Off Jack with Crane.



SPECIFICATIONS AND ACCESSORIES

O-Ring/Lock Ring Installer

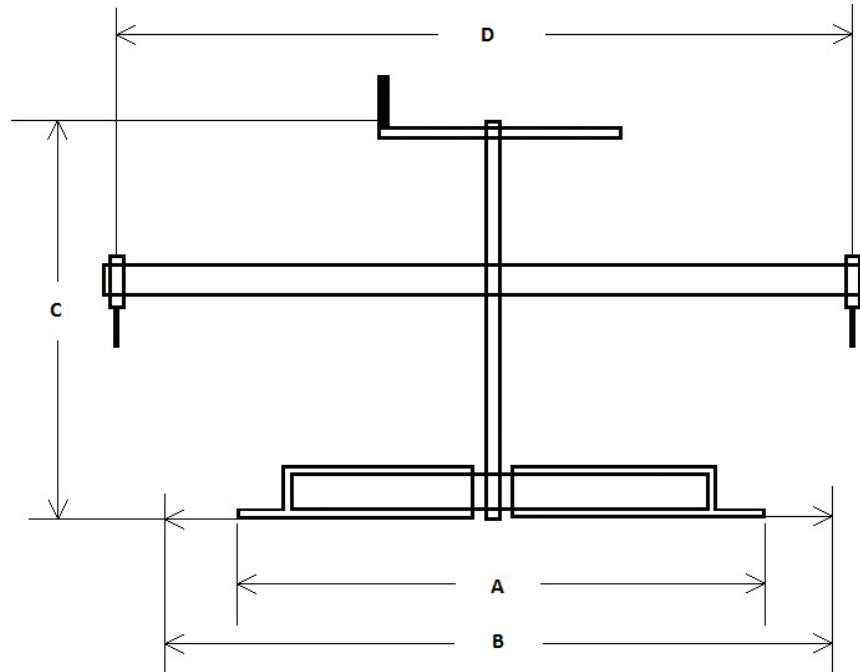

		A	B	C	D	Weight
	MODEL #70162	22.25 in 565 mm	32 in 813 mm	18 in 457 mm	28 in 711 mm	22 lbs. 10 kg
XL	MODEL #70164	27.75 in 705 mm	40 in 1016 mm	18 in 457 mm	44 in 1118 mm	30 lbs. 14 kg

ACCESSORIES: For Extended Planetary Flange Wheels



MODEL 70163

For 24" Through 29"



MODEL 70162K

MODEL 70162 + 70163



Stay
Connected



TF - 1.800.352.9852 • P - 352.754.1117 • F - 352.754.4508
E - sales@esco.net • WWW.ESCO.NET

