

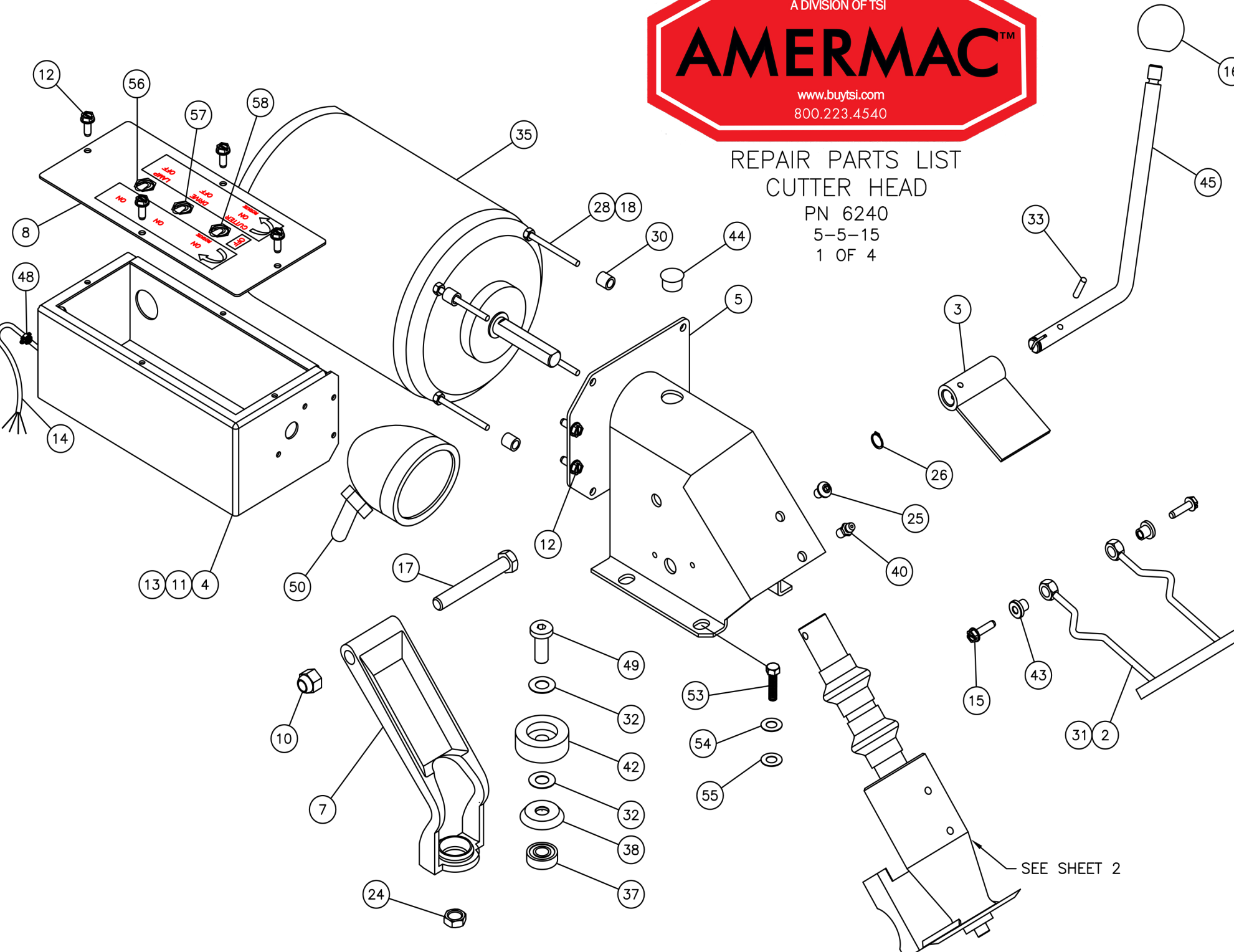

REPAIR PARTS LIST  
CUTTER HEAD

PN 6240  
5-5-15  
1 OF 4





# REPAIR PARTS LIST CUTTER HEAD

PN 6240

5-5-15  
2 OF 4

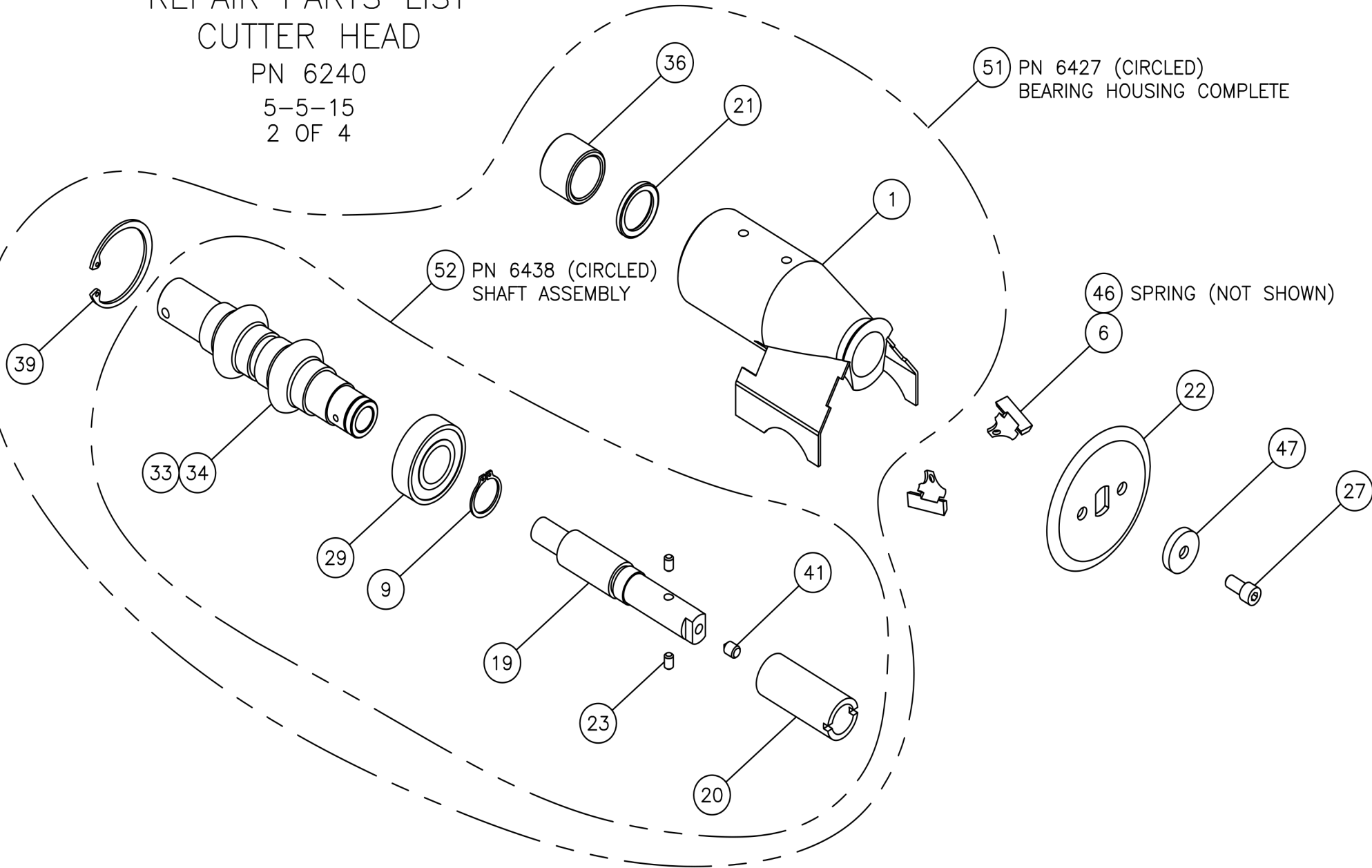



# CUTTER HEAD

## REPAIR PARTS BOM

Page 1 of 1

PN: 6240  
 BEGINNING SERIAL NO.0000  
 5/5/2015

### PARTS LIST

ITEM	PART NO.	DESCRIPTION	QTY
1	6241	BEARING HOUSING WELD	1
2	6242	BLADE GUARD	1
3	6248	PRESSURE LEVER	1
4	6254	ELEC BOX, WELD	1
5	6457	CUT HEAD, HOUSING WELD, 405	1
	6283	CUT HEAD, HOUSING WELD, 711,1100,1200	
6	6306	SPRING MOUNTED CARBIDE	2
7	6307	STONE CARRIAGE WELD	1
8	6308	CONTROL BOX WIRE DIAGRAM	1
9	196	SNAP RING 3/4 EXT	1
10	212	NUT 3/8-16 HEX NYLOK	1
11	15032	CONDUIT NIPPLE 1/2" RIGID	1
12	1055	WHCS #10-24 X 1/2 LG SELF TAP	6
13	1292	WIRE 16 GA TW STRANDED	AR
14	15333	CORD, ELECTRIC 16/4	AR
15	4569	HWHST #10-24 X 3/4 LG SELF TAP	2
16	4780	KNOB 1-5/16 DIA X 3/8-16 THD	1
17	10374	HHCS 3/8-16 X 3	1
18	10401	NUT #8-32 NYLOK	4
19	15000	SHAFT, CUTTER HEAD	1
20	15002	SLEEVE, ADJUSTMENT	1
21	15004	SEAL	1
22	15005	BLADE	1
23	15012	SLEEVE, LOCKING PIN	2
24	15021	JAM NUT 3/8-24	1
25	15022	BHCS 1/4-20 X 3/8	1
26	15023	SPRING-CLIP 7/16" DIA SHAFT X .035" THK	1
27	15025	SHCS 1/4-20 X 1/2	1
28	15029	MACH SCREW #8-32 X 7" LG	4
29	15030	BEARING .78 ID X 1.652 OD X .468 WIDE	1

### PARTS LIST

ITEM	PART NO.	DESCRIPTION	QTY
30	15033	TUBE, SPACER MOTOR	4
31	15034	DECAL - SHARP BLADE	2
32	15043	PAPER WASHER	2
33	15044	SPRING PIN 5/32 DIA X 3/4	2
34	15066	UNIVERSAL JOINT MODIFIED	1
35	15067	MOTOR 1/3 HP 115V 60Hz 1800 rpm	1
36	15094	BUSHING, BRONZE	1
37	15138	BEARING, STONE	1
38	15211	STONE, DUST CAP	1
39	15223	SNAP RING 1-3/4 DIA X .062 THK	1
40	15224	ZERK 1L 1/4-28 STRAIGHT	1
41	15225	SHSS 1/4-20 X 3/8 POINTED	1
42	15226	STONE	1
43	15227	BUSHING, BLADE GUARD	1
44	15230	HOLE PLUG	1
45	15231	ARM, SHARPENER	1
46	15232	SPRING, CARBIDE HOLDER	2
47	15233	WASHER, BLADE MOUNTING	1
48	15241	STRAIN RELIEF - HEYCO 7P-2	1
49	15229	BOLT, GRINDING STONE	1
50	15297	LAMP ASSEMBLY, HALOGEN	1
51	6427	BEARING HOUSING COMPLETE	REF
52	6438	SHAFT ASSEMBLY	REF
53	368	HHCS 5/16-18 X 5/8	4
54	1630	SPRING LOCK WASHER	4
55	445	FLAT WROUGHT WASHER	4
56	15076	TOGGLE SWITCH #2 TERMINAL	1
57	15075	TOGGLE SWITCH #4 TERMINAL	1
58	15074	TOGGLE SWITCH #12 TERMINAL	1

ELEC PARTS FOR ASSY		
TOGGLE	TERM CONN	QTY
15074	15217	5
	15294	5
	15295	15
	15296	3
15075	15217	2
	15294	2
	15295	4
15076	15295	2

USE GASOLINE RESISTANT  
UL APPROVED 16 AWG  
WIRE AS REQUIRED.

ELEC PARTS TO CONNECT TO  
LAMP AND MOTOR INCLUDED.

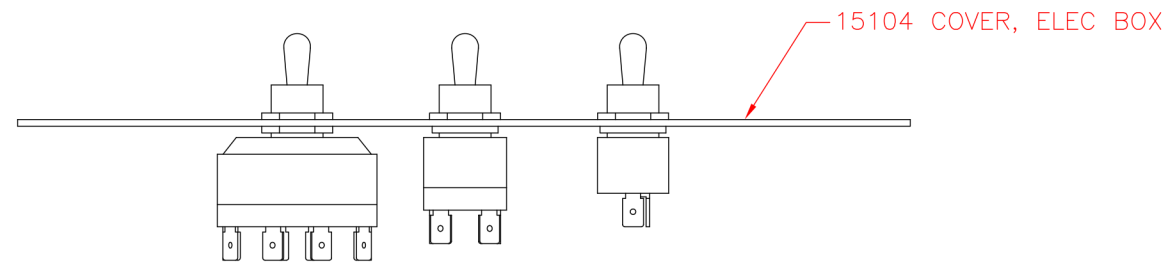
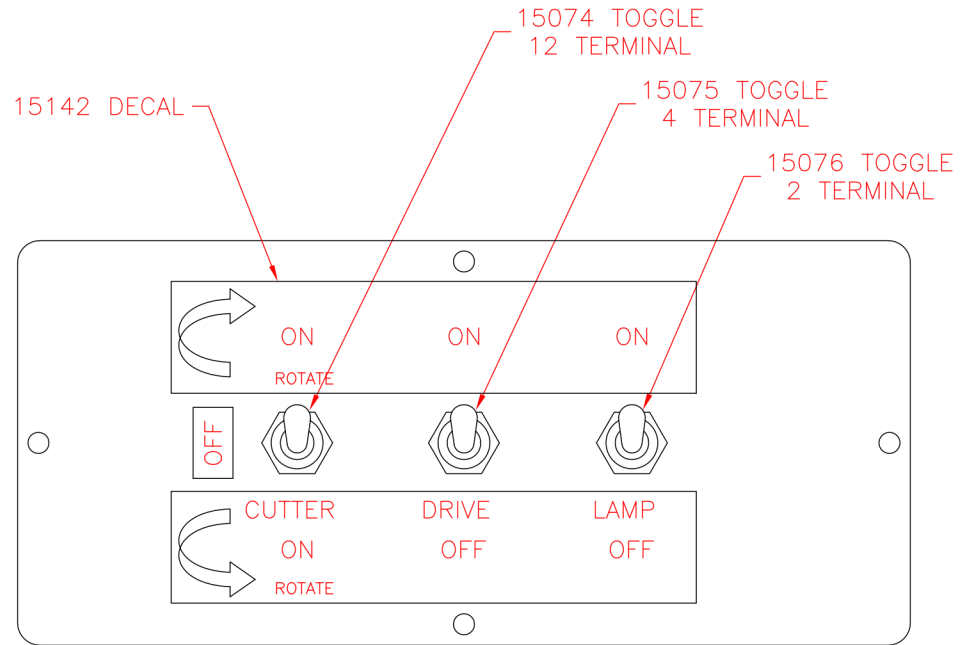

1. REMOVE ALL BURRS & SHARP EDGES.

NOTE:

THE SUBJECT OF THIS DRAWING IS SUBMITTED IN CONFIDENCE AND IT AND THE DRAWING WILL AND SHALL REMAIN THE PROPERTY OF TIRE SERVICE EQUIPMENT INC. AND ARE NOT TO BE USED WITHOUT ITS WRITTEN PERMISSION AND APPROVAL. © 2010	MATL: SEE DRAWING	DESIGNER: M. REDISKE	SCALE: N/A	REV	DESCRIPTION	DATE
	TOLERANCE UNLESS NOTED: DECIMALS ±.010 FRACTIONS ±1/32 ANGLES ±1/2°	DR. BY: M. REDISKE	DATE: 05/24/10	USED ON: 711	SHEET: 1 OF 2	
				PART NAME: CONTROL BOX WIRE DIAGRAM		QTY PER UNIT: NA
				C	DWG NO. 6308	

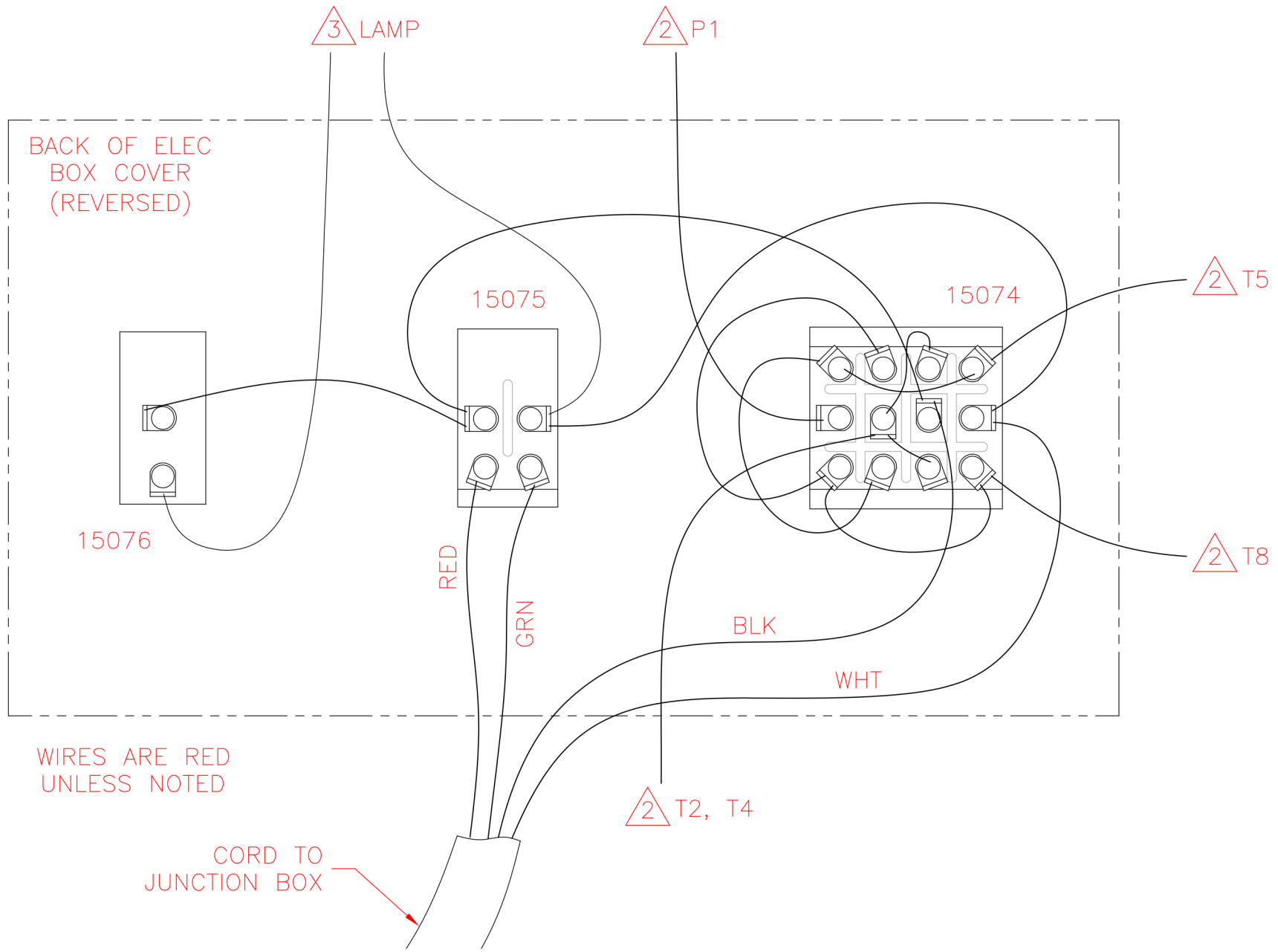

BACK OF ELEC BOX COVER (REVERSED)

15075

15074

15076

RED

GRN

BLK

WHT

WIRES ARE RED UNLESS NOTED

CORD TO JUNCTION BOX

3 LAMP

2 P1

2 T5

2 T8

2 T2, T4

3 LOCATION TO CONNECT LAMP.  
 2 WIRES P1, T2, T4, T5 & T8 REFER TO A LEESON MOTOR SOURCE. THE SAME LEADS CAN BE USED ON A MARATHON MOTOR SOURCE.

NOTE: 1. REMOVE ALL BURRS & SHARP EDGES.

THE SUBJECT OF THIS DRAWING IS SUBMITTED IN CONFIDENCE AND IT AND THE DRAWING WILL AND SHALL REMAIN THE PROPERTY OF TIRE SERVICE EQUIPMENT INC. AND ARE NOT TO BE USED WITHOUT ITS WRITTEN PERMISSION AND APPROVAL. © 2010

MATL: SEE DRAWING  
 TOLERANCE UNLESS NOTED:  
 DECIMALS ±.010  
 FRACTIONS ±1/32  
 ANGLES ±1/2°

DESIGNER: M. REDISKE  
 DR. BY: M. REDISKE  
 CH. BY:  
 SCALE: N/A  
 DATE: 05/24/10  
 INT:



REV	DESCRIPTION	DATE
USED ON: 711		SHEET: 2 OF 2
PART NAME: CONTROL BOX WIRE DIAGRAM		QTY PER NA UNIT:
C	DWG NO. 6308	